

# Metoda Sił

Rysowanie wykresów sił wewnętrznych  
w ramach statycznie niewyznaczalnych

*dr inż. Hanna Weber*

Zadanie: Narysuj wykresy sił N, T, M.  
Zadanie rozwiąż metodą sił.

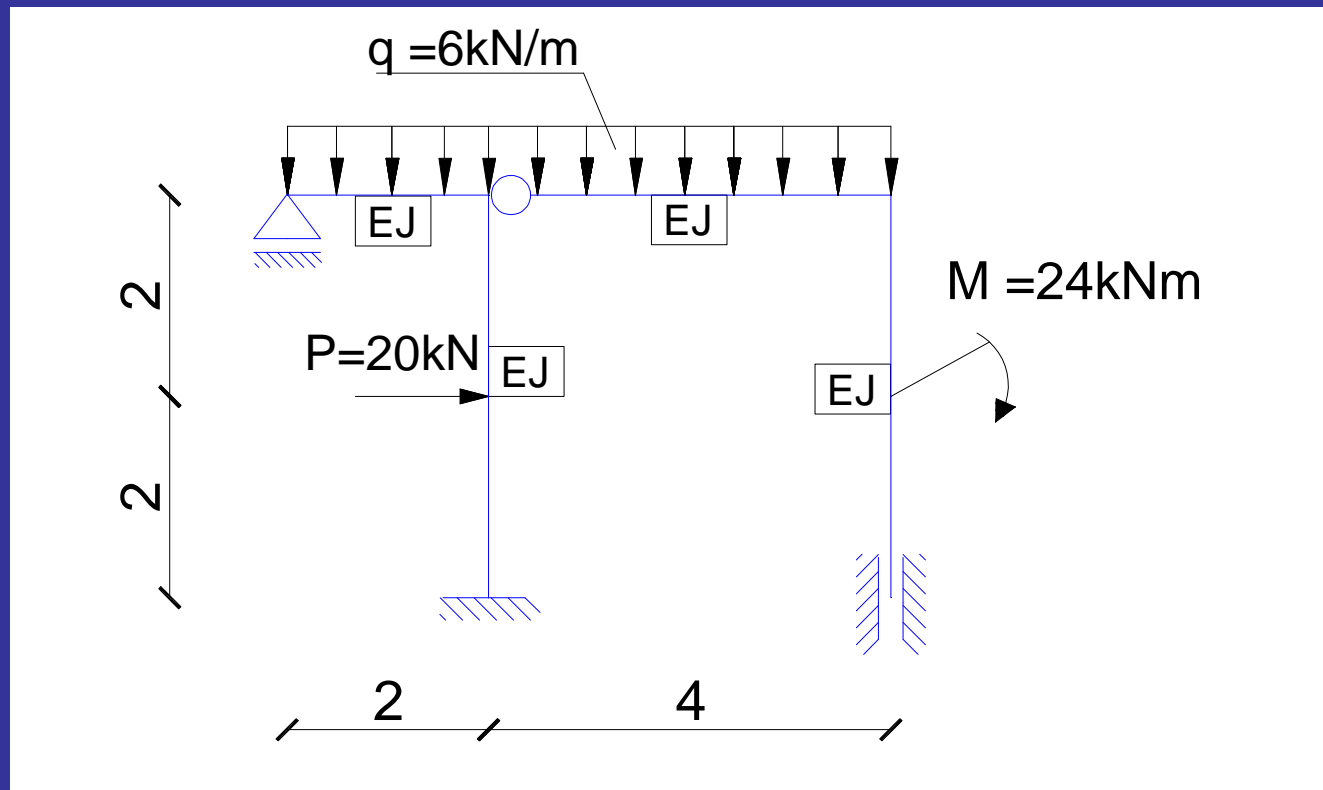

dr inż. Hanna Weber

## Określenie stopnia statycznej niewyznaczalności :

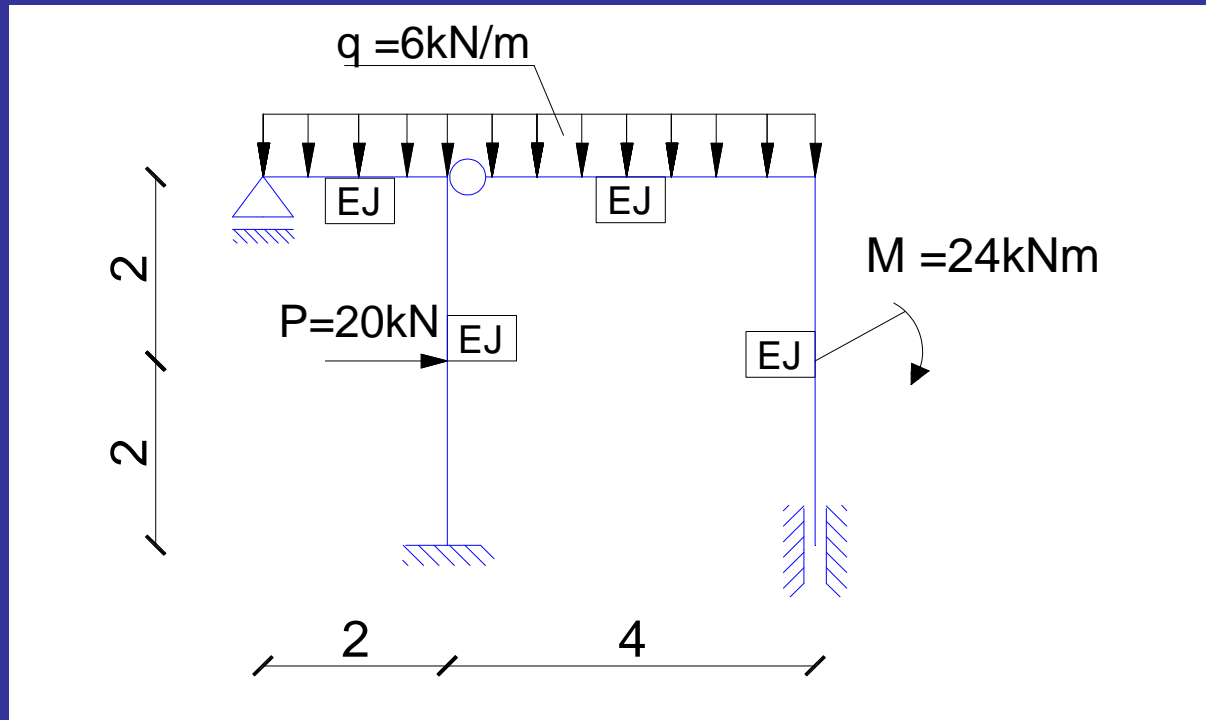

$$n_s = l_r - l_p - 3 = 6 - 1 - 3 = 2$$

Układ dwukrotnie statycznie niewyznaczalny

## Schemat podstawowy statycznie wyznaczalny:

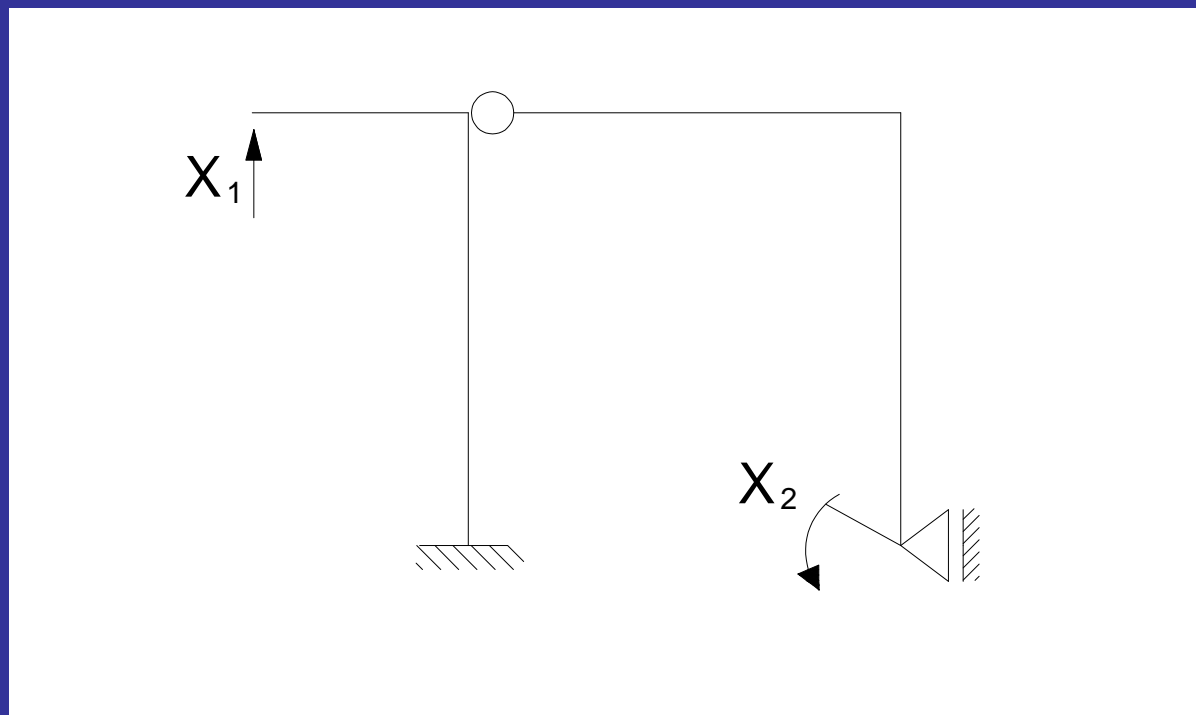

*dr inż. Hanna Weber*

# Wykres $X_1=1$

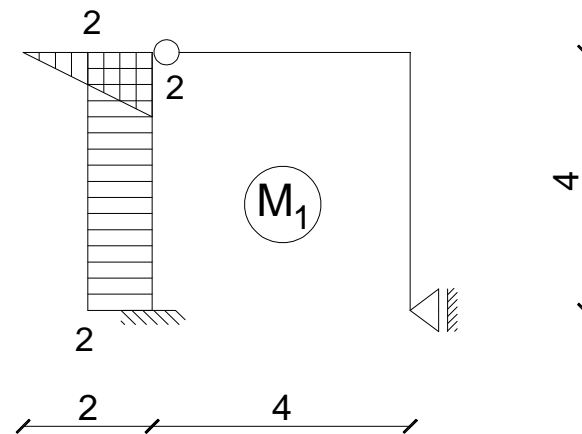
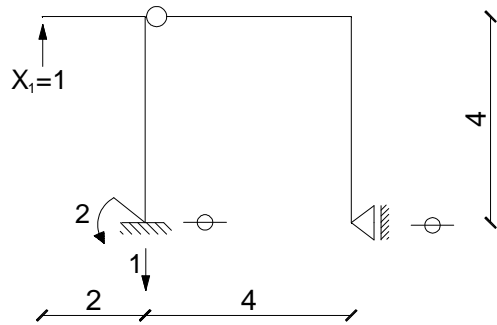

# Wykres $X_2=1$

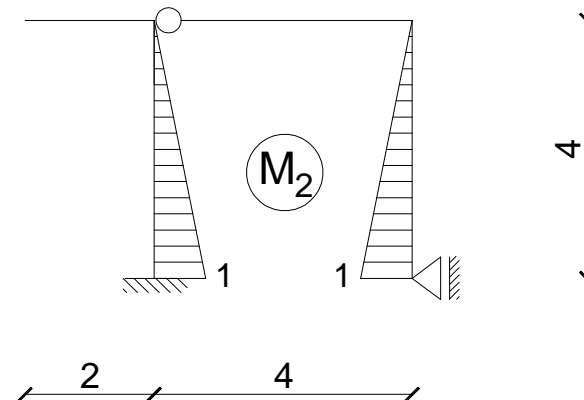
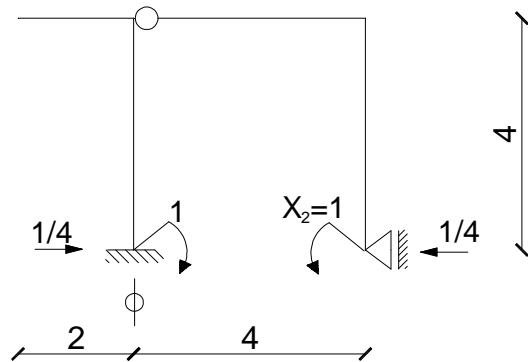

# Wykres od obciążenia zewnętrznego:

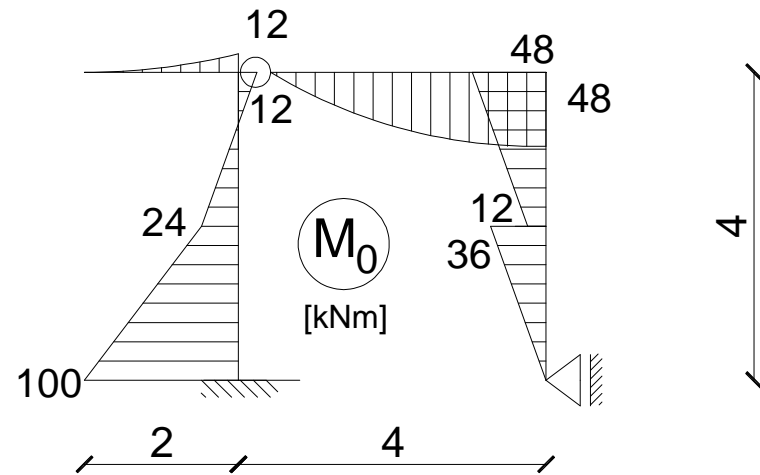
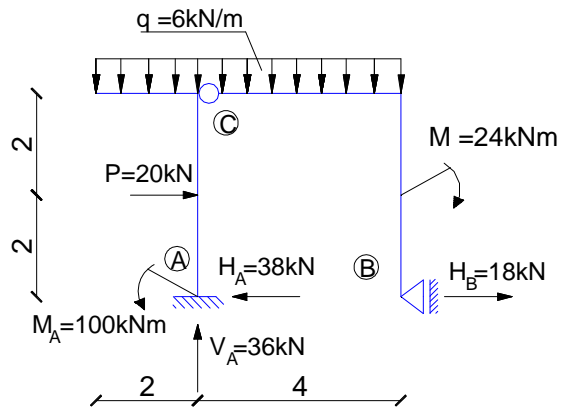

## Całkowanie wykresów:

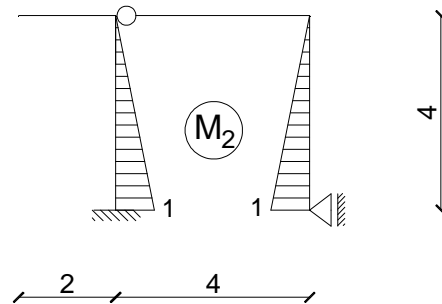
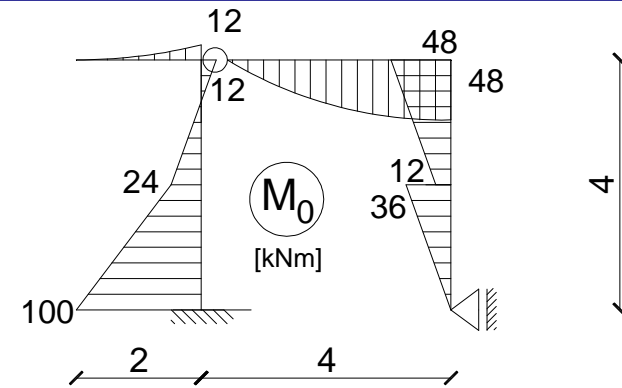
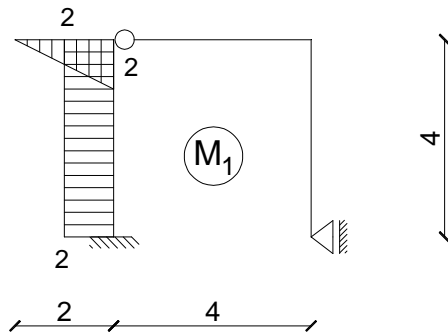

$$\delta_{11} = \frac{1}{EI} \left( \frac{1}{2} \cdot 2 \cdot 2 \cdot \frac{2}{3} \cdot 2 + 2 \cdot 4 \cdot 2 \right) = \frac{56}{3EI}$$

$$\delta_{12} = -\frac{1}{EI} \left( 2 \cdot 4 \cdot \frac{1}{2} \cdot 1 \right) = -\frac{4}{EI} = \delta_{21}$$

$$\delta_{22} = \frac{1}{EI} \left( \frac{1}{2} \cdot 1 \cdot 4 \cdot \frac{2}{3} \cdot 1 + \frac{1}{2} \cdot 1 \cdot 4 \cdot \frac{2}{3} \cdot 1 \right) = \frac{8}{3EI}$$

dr inż. Hanna Weber



## Całkowanie wykresów:

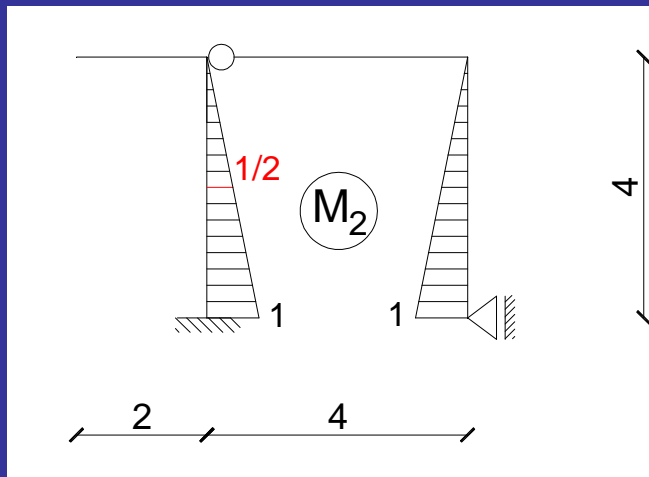
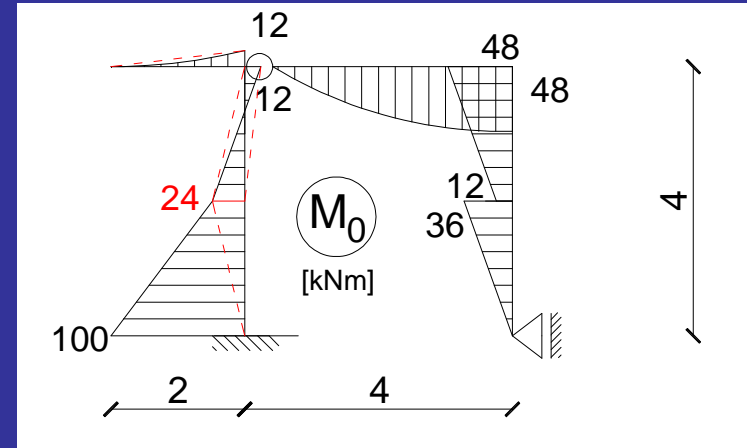
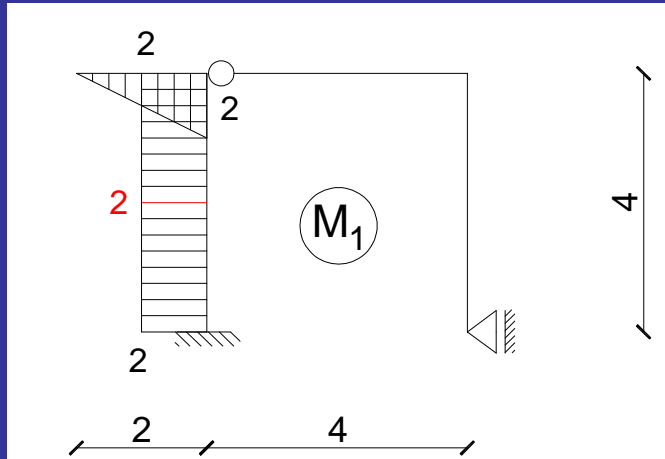

$$\delta_{10} = \frac{1}{EI} \left( -\frac{1}{2} \cdot 12 \cdot 2 \cdot \frac{2}{3} \cdot 2 + \frac{2}{3} \cdot \frac{6 \cdot 2^2}{8} \cdot 2 \cdot \frac{1}{2} \cdot 2 \right) + \frac{1}{EI} 2 \cdot 2 \cdot \left( \frac{24}{2} - \frac{12}{2} \right) + \frac{1}{EI} 2 \cdot 2 \cdot \left( \frac{100}{2} + \frac{24}{2} \right) = \frac{260}{EI}$$

dr inż. Hanna Weber

## Całkowanie wykresów:

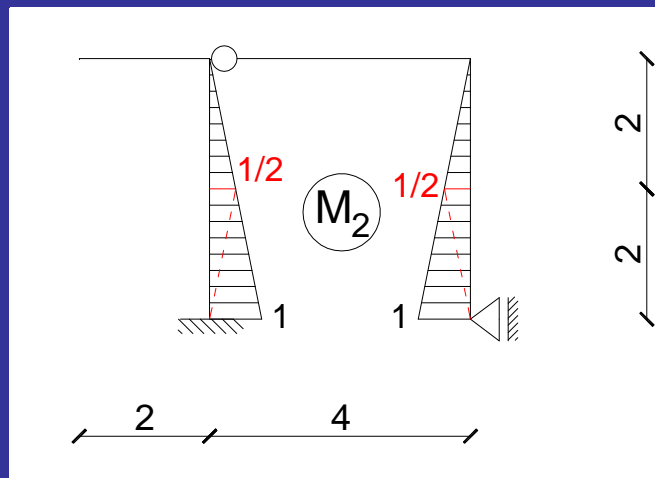
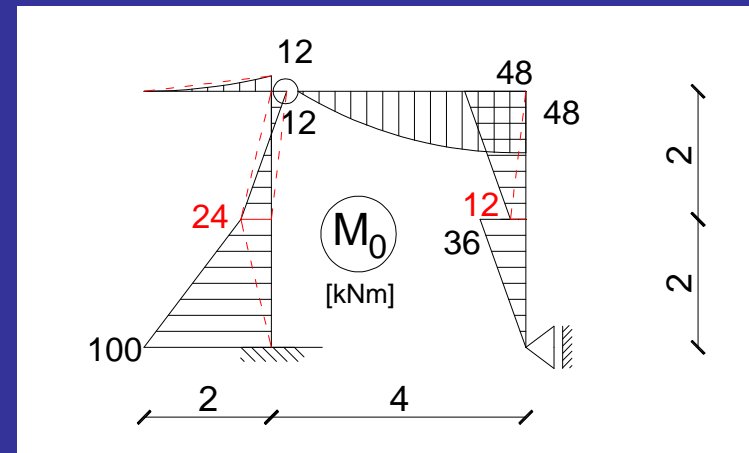
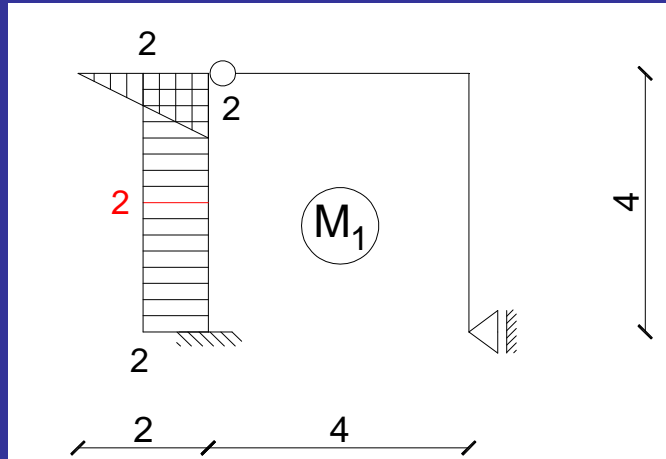

$$\begin{aligned} \delta_{20} = & \frac{1}{EI} \left( \frac{1}{2} \cdot \frac{1}{2} \cdot 2 \cdot \left( \frac{1}{3} \cdot 12 - \frac{2}{3} \cdot 24 \right) - \frac{1}{2} \cdot \frac{1}{2} \cdot 2 \cdot \left( \frac{2}{3} \cdot 24 + \frac{1}{3} \cdot 100 \right) \right) \\ & - \frac{1}{EI} \frac{1}{2} \cdot 1 \cdot 2 \cdot \left( \frac{2}{3} \cdot 100 + \frac{1}{3} \cdot 24 \right) + \frac{1}{EI} \frac{1}{2} \cdot \frac{1}{2} \cdot 2 \cdot \left( \frac{2}{3} \cdot 12 + \frac{1}{3} \cdot 48 \right) \\ & + \frac{1}{EI} \frac{1}{2} \cdot 36 \cdot 2 \cdot \left( \frac{2}{3} \cdot \frac{1}{2} + \frac{1}{3} \cdot 1 \right) = -\frac{208}{3EI} \end{aligned}$$

dr inż. Hanna Weber

Układ równań kanonicznych metody sił  
dla schematu dwukrotnie statycznie  
niewyznaczalnego:

$$\begin{cases} \delta_{11} \cdot X_1 + \delta_{12} \cdot X_2 + \delta_{10} = 0 \\ \delta_{21} \cdot X_1 + \delta_{22} \cdot X_2 + \delta_{20} = 0 \end{cases}$$

$$\begin{cases} \frac{56}{3EI} \cdot X_1 - \frac{4}{EI} \cdot X_2 + \frac{260}{EI} = 0 \\ -\frac{4}{EI} \cdot X_1 + \frac{8}{3EI} \cdot X_2 - \frac{208}{3EI} = 0 \end{cases}$$

↓

$$X_1 = -12,32kN$$

$$X_2 = 7,52kNm$$

*dr inż. Hanna Weber*

# Tworzenie ostatecznego wykresu momentów:

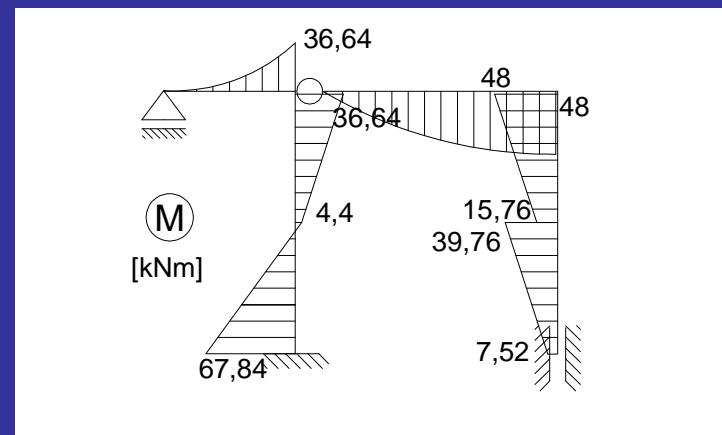
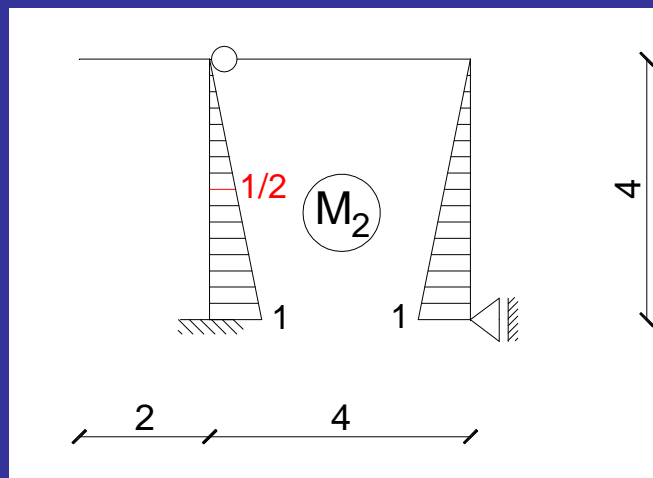
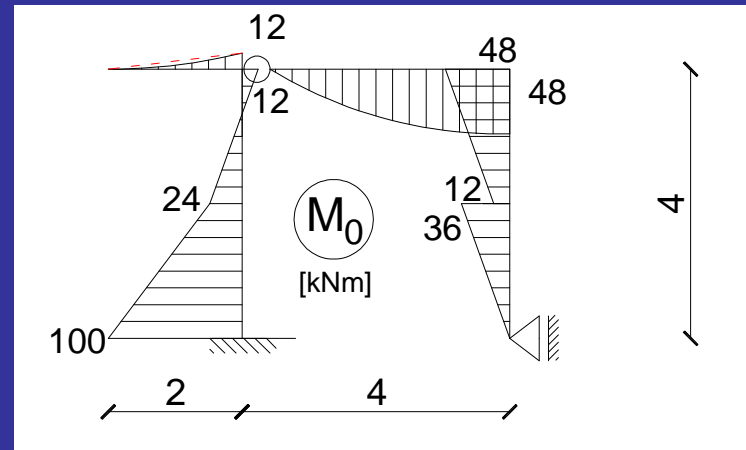
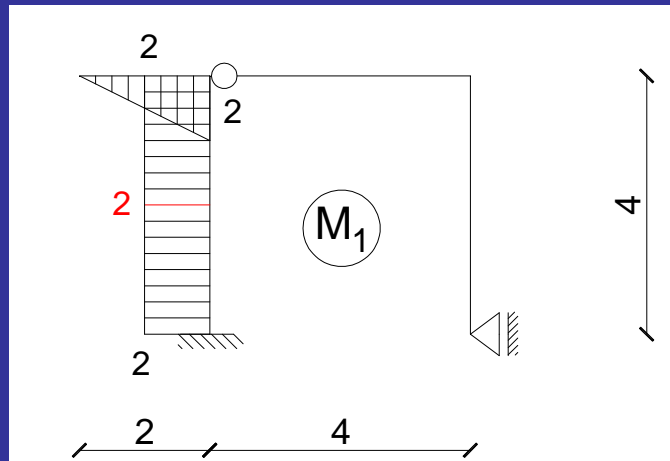

$$M_i = M_{i1} \cdot X_1 + M_{i2} \cdot X_2 + M_{i0}$$

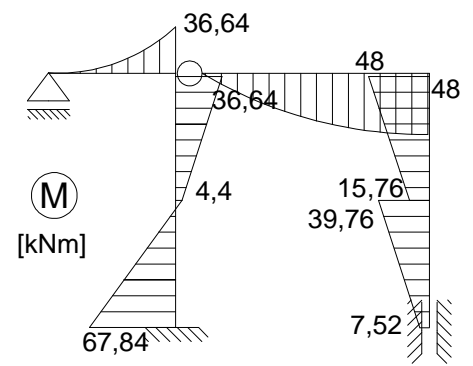
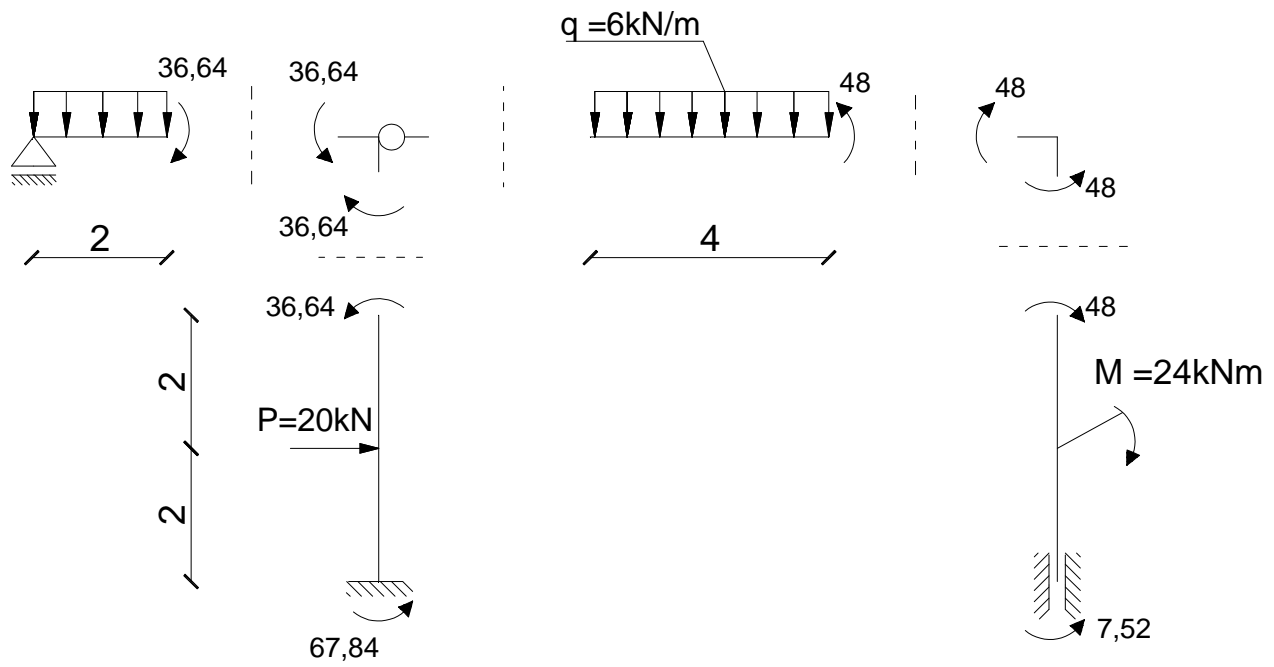

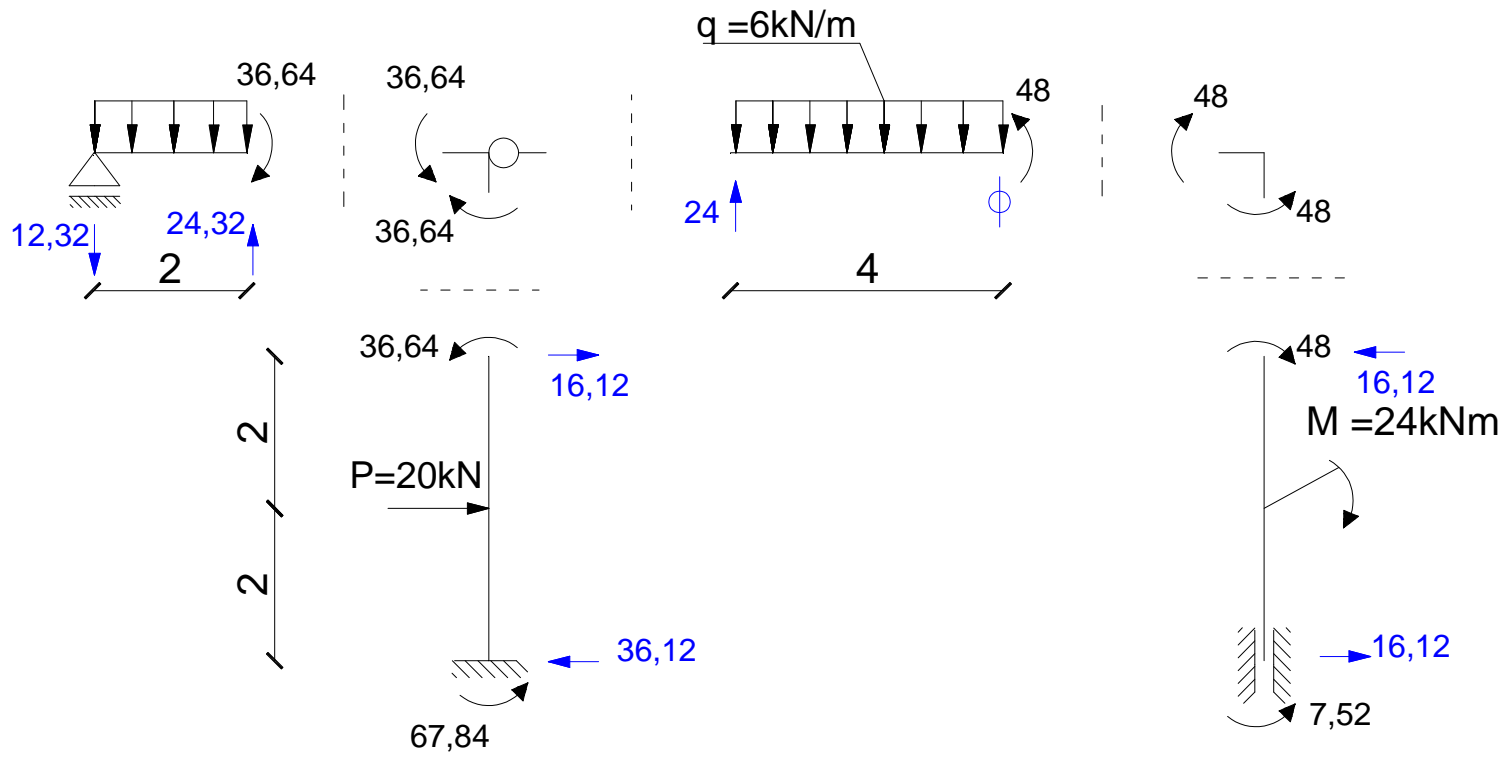

dr inż. Hanna Weber

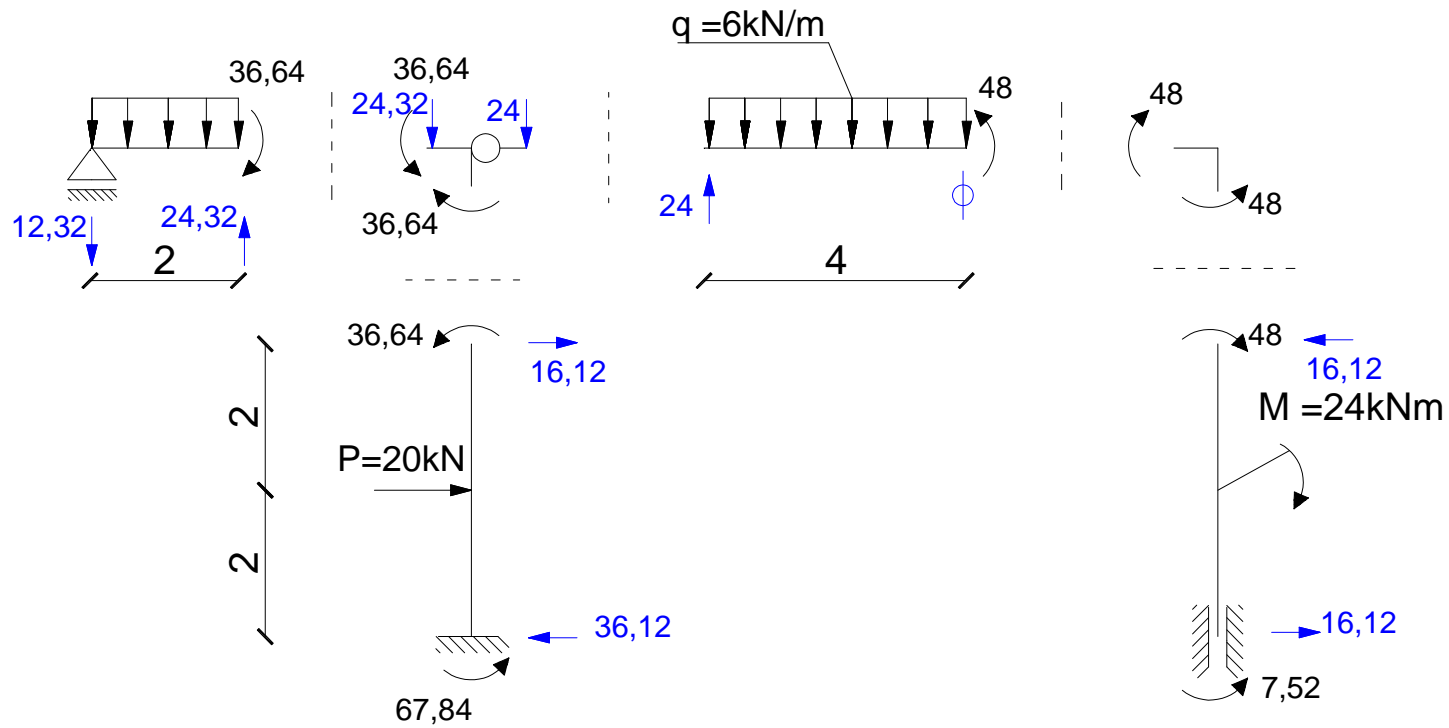

dr inż. Hanna Weber

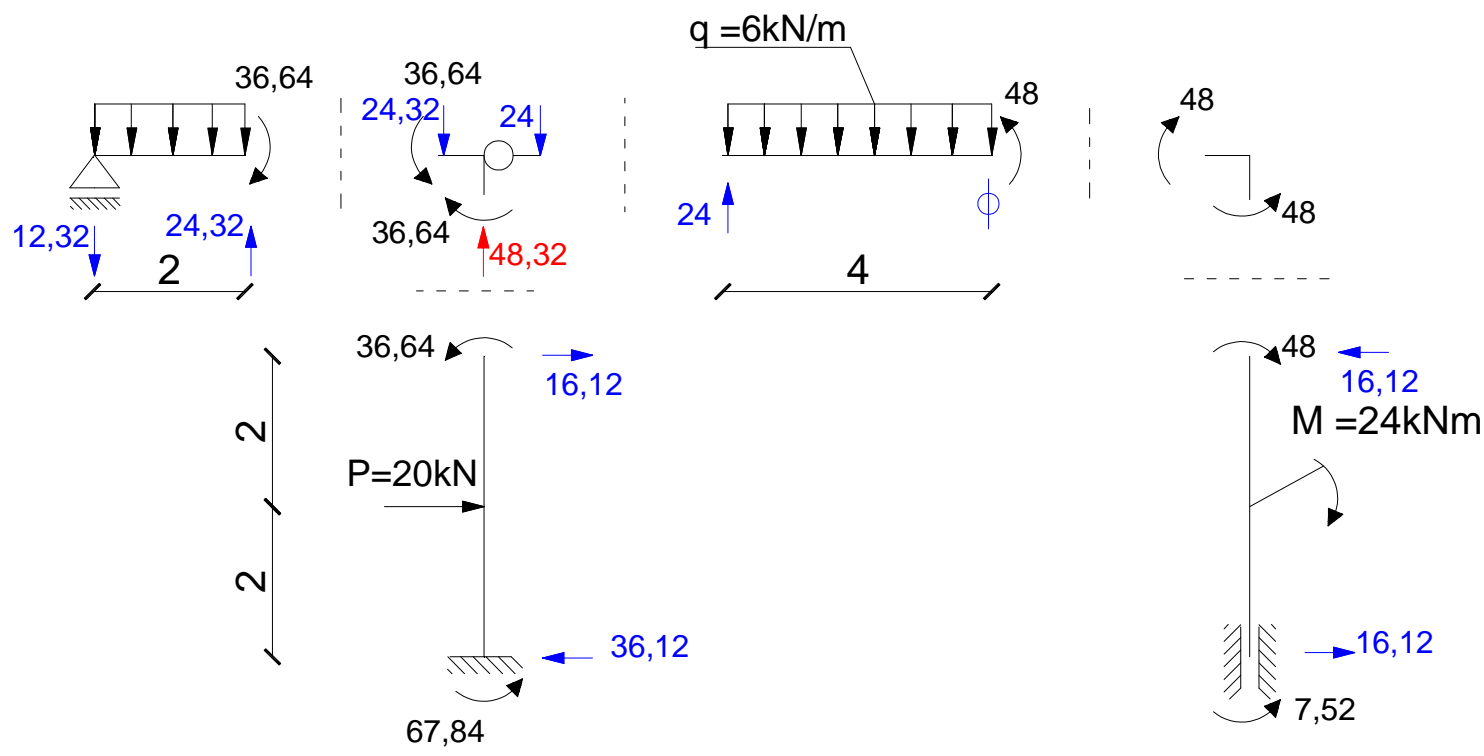

dr inż. Hanna Weber



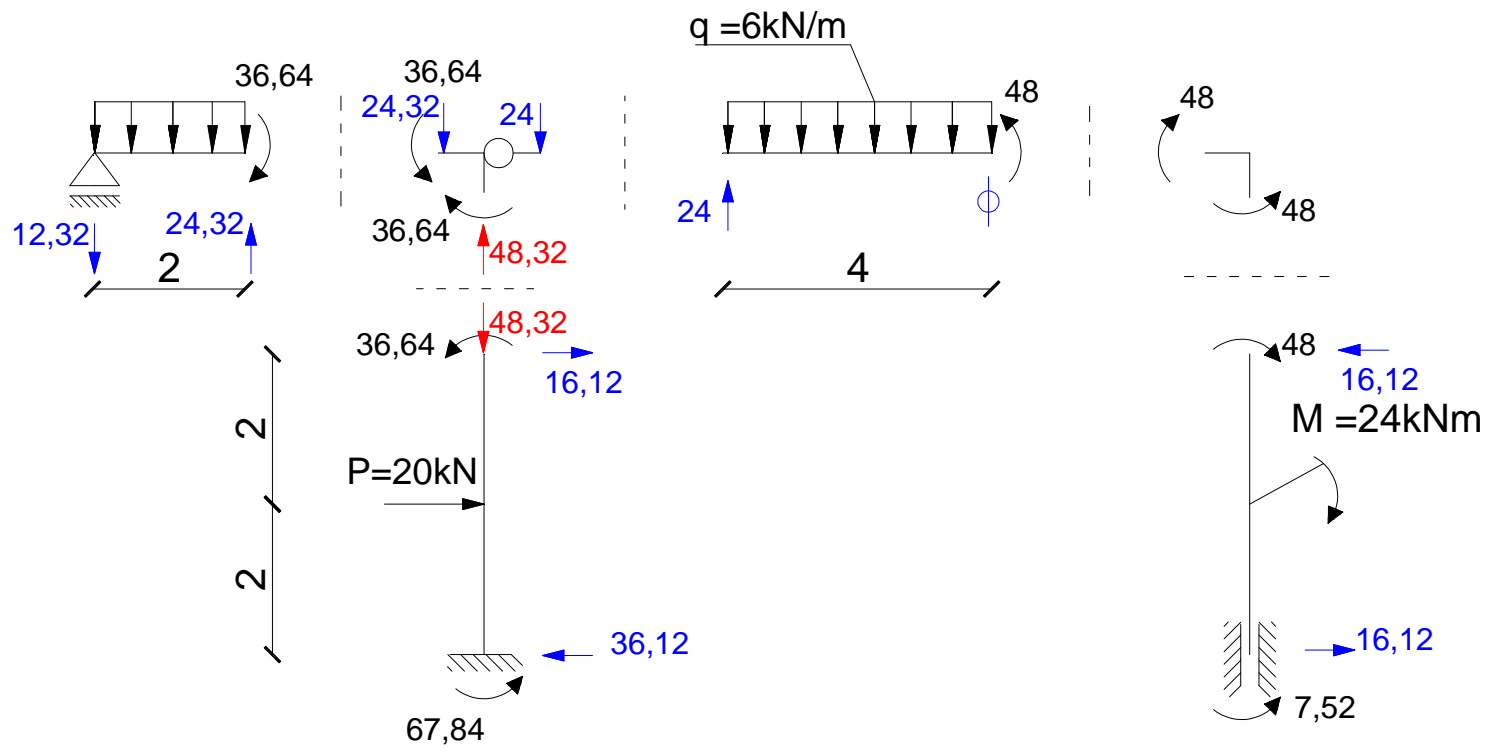

dr inż. Hanna Weber

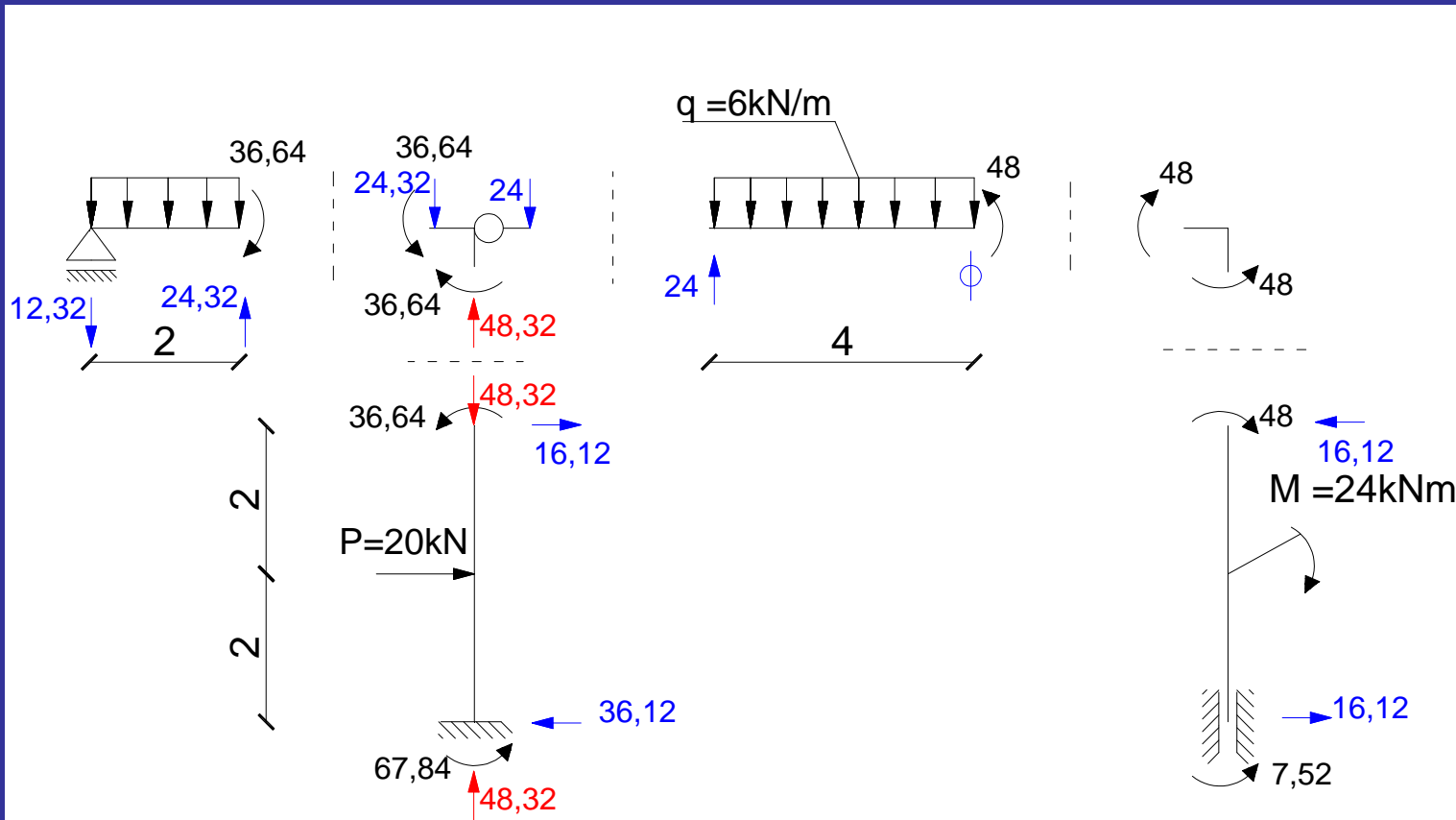

dr inż. Hanna Weber

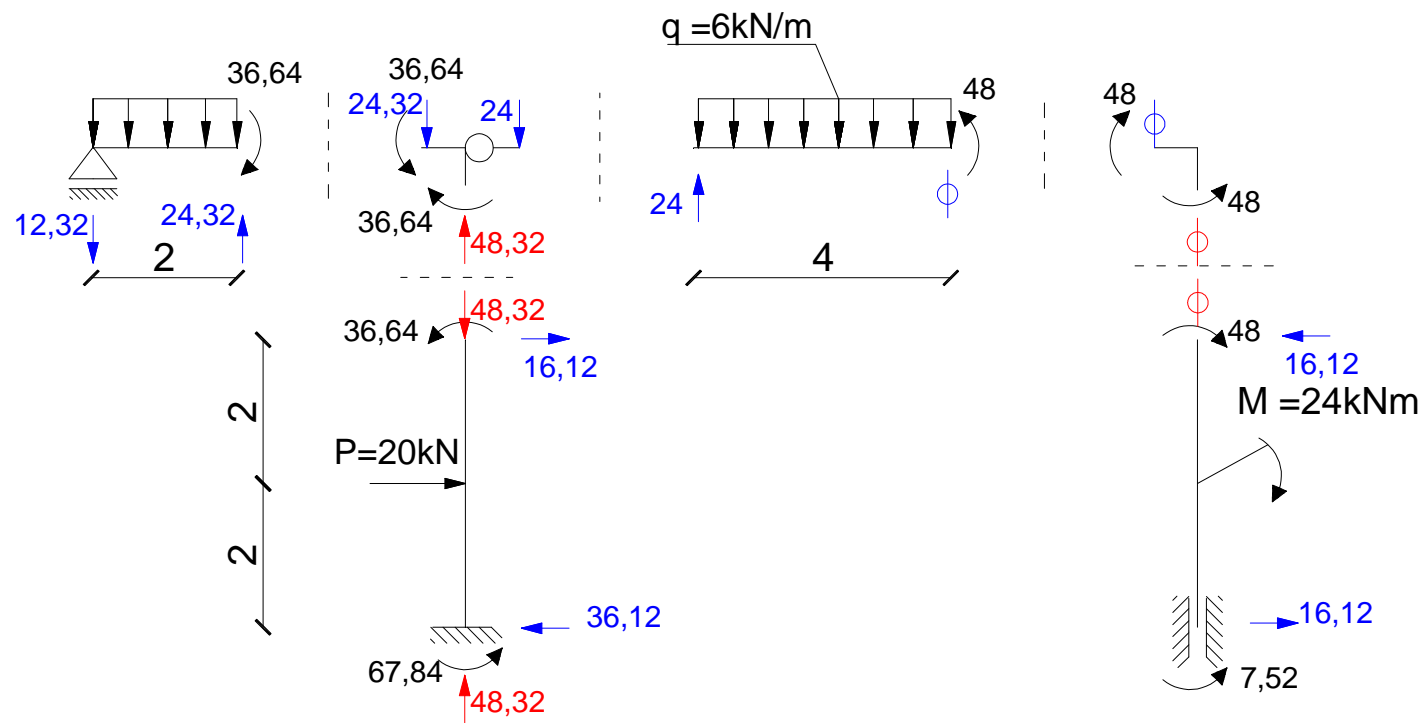

dr inż. Hanna Weber

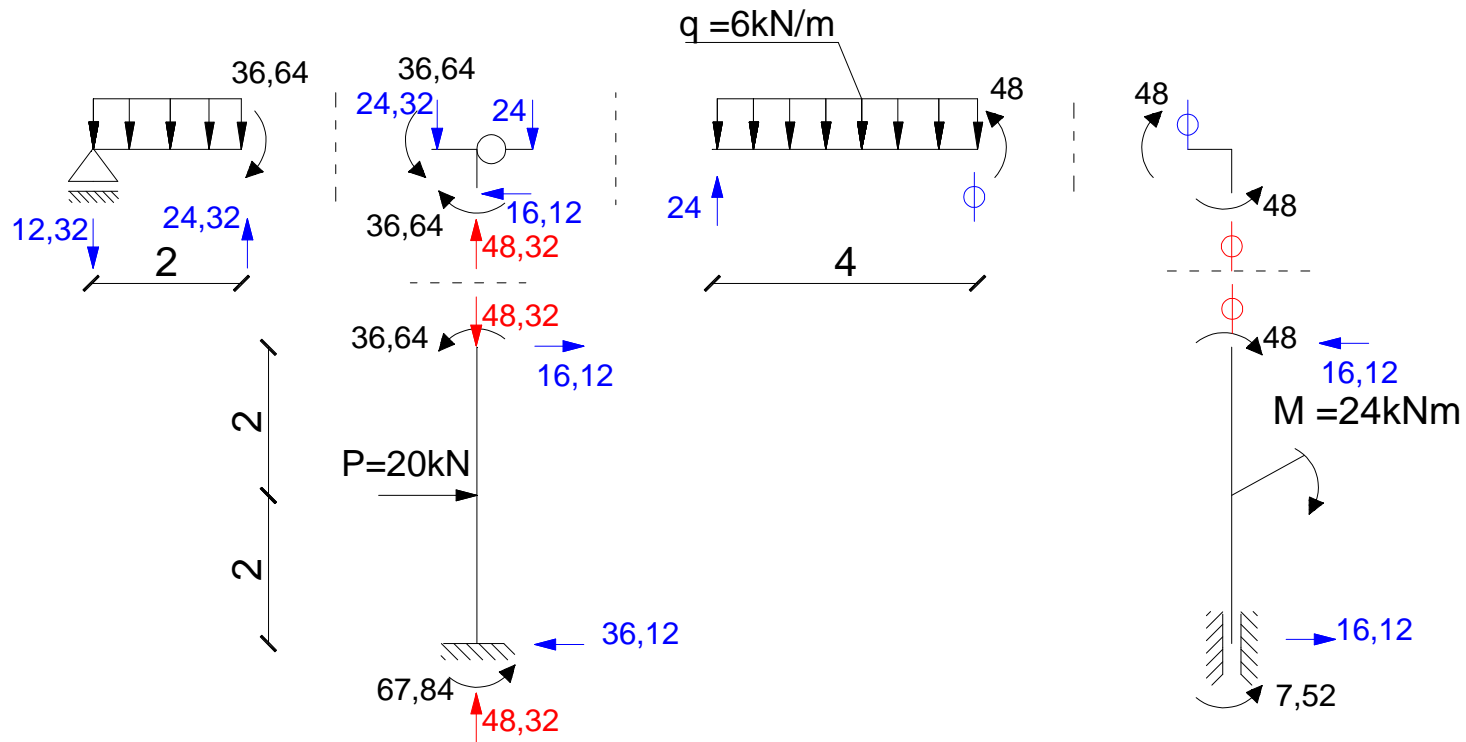

dr inż. Hanna Weber

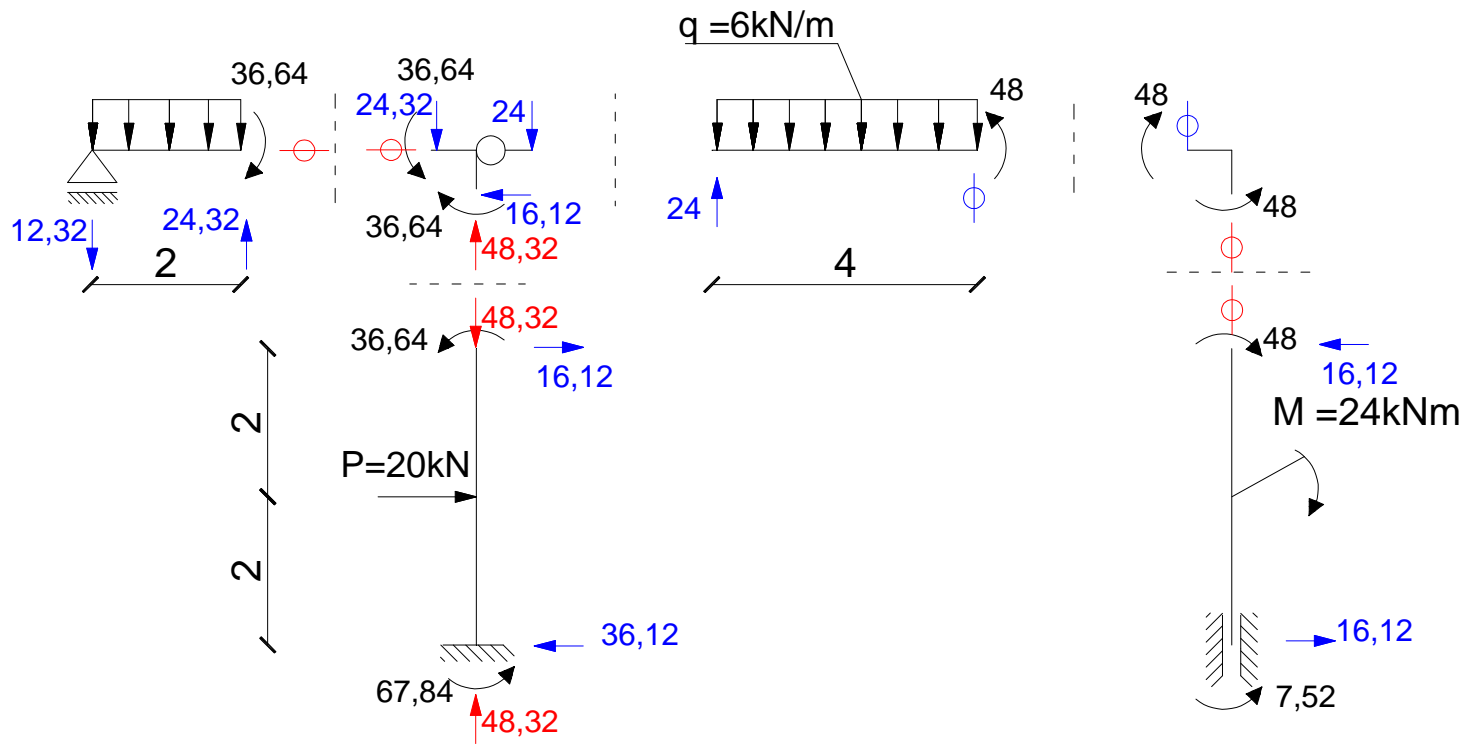

dr inż. Hanna Weber

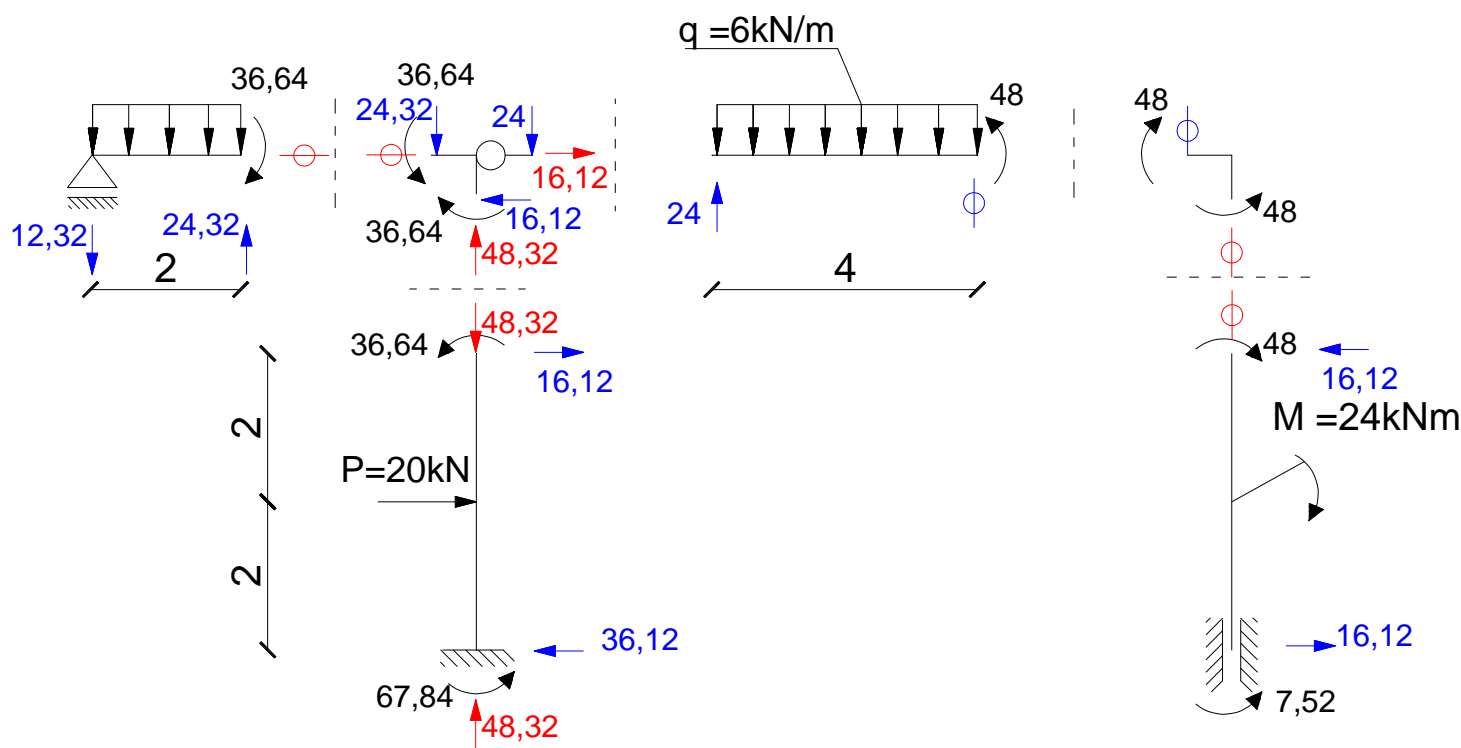

dr inż. Hanna Weber

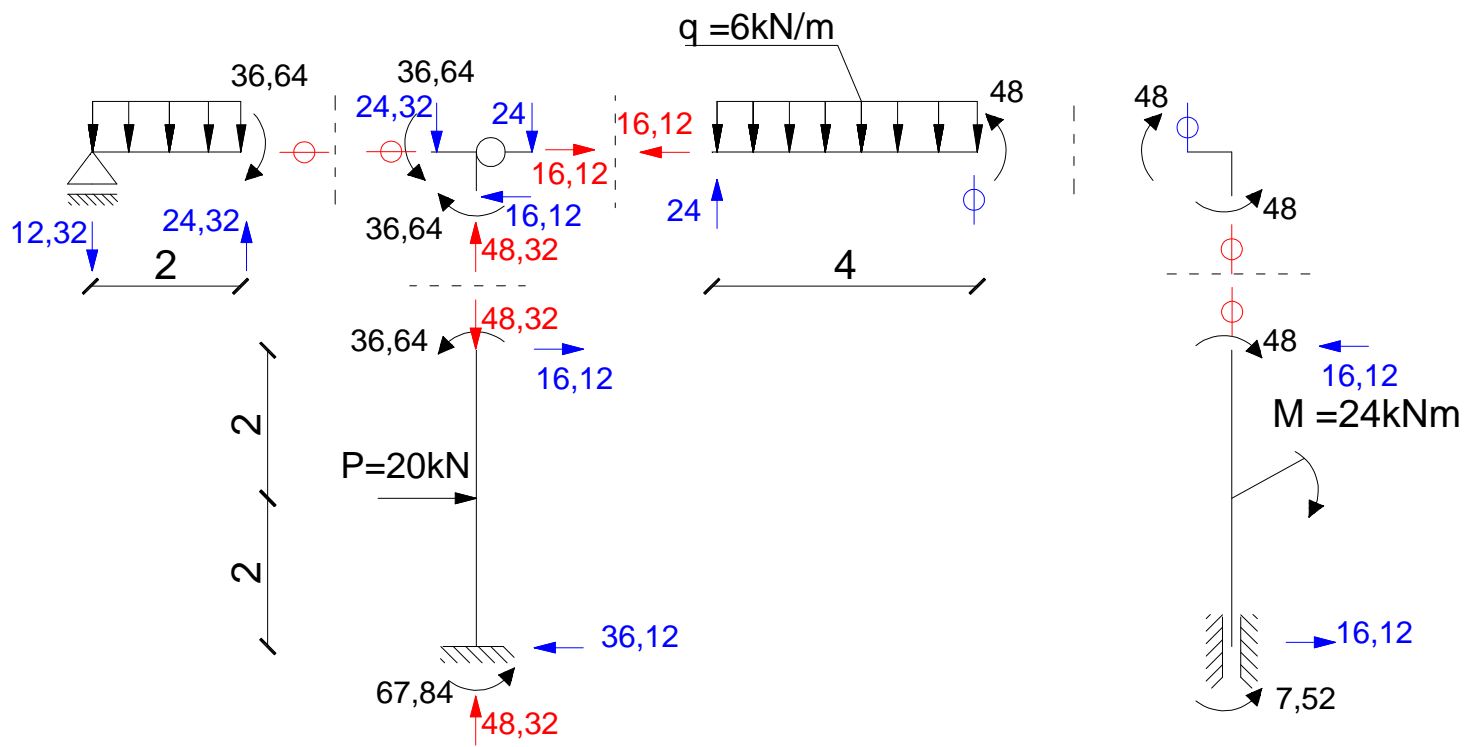

dr inż. Hanna Weber

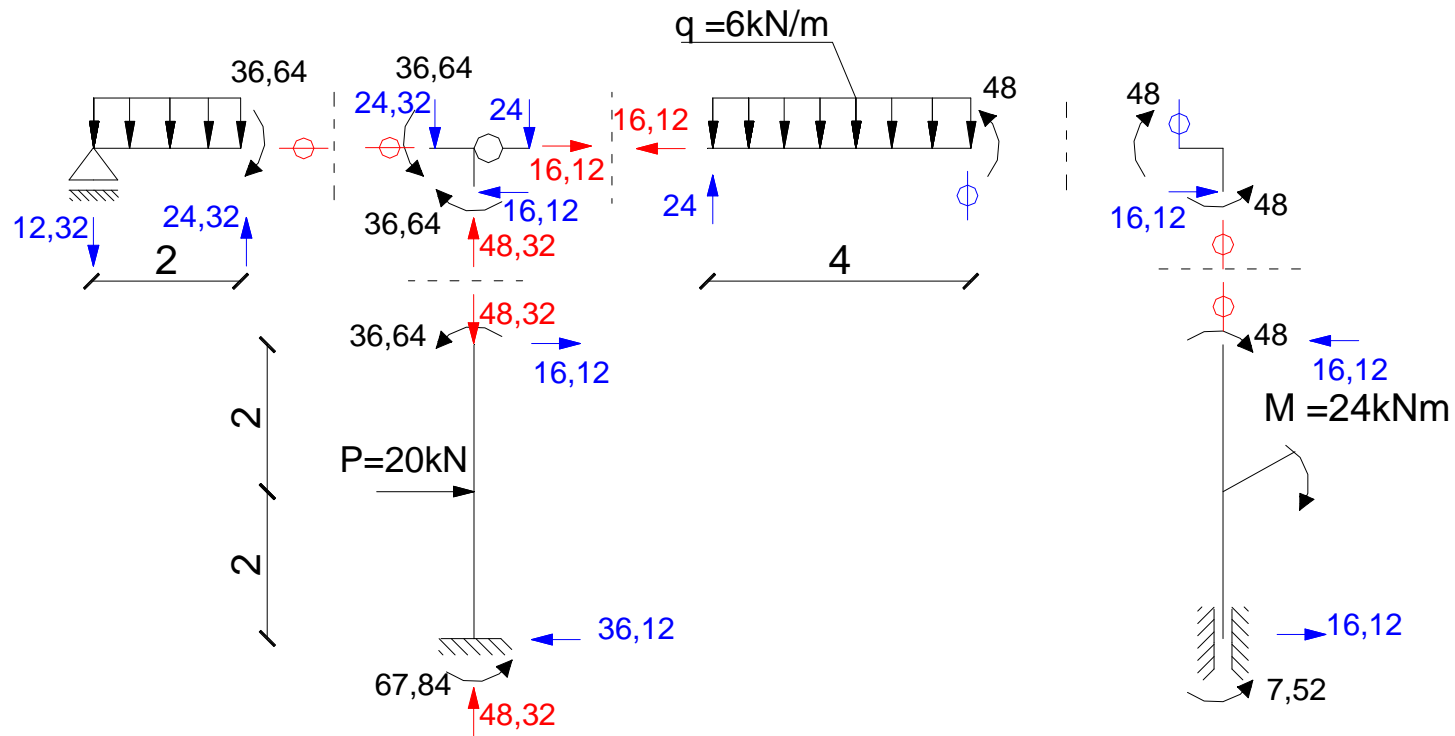

dr inż. Hanna Weber



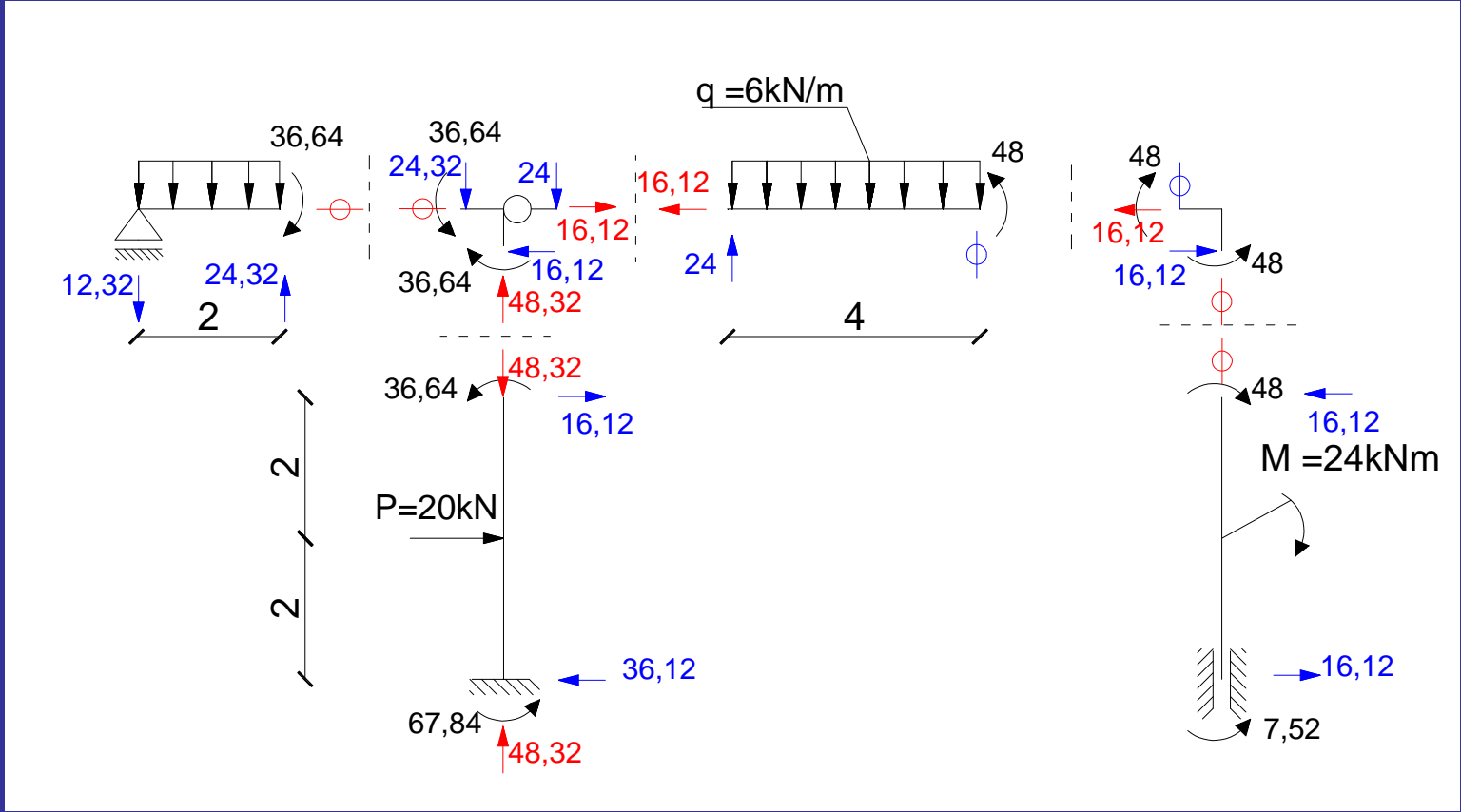

dr inż. Hanna Weber

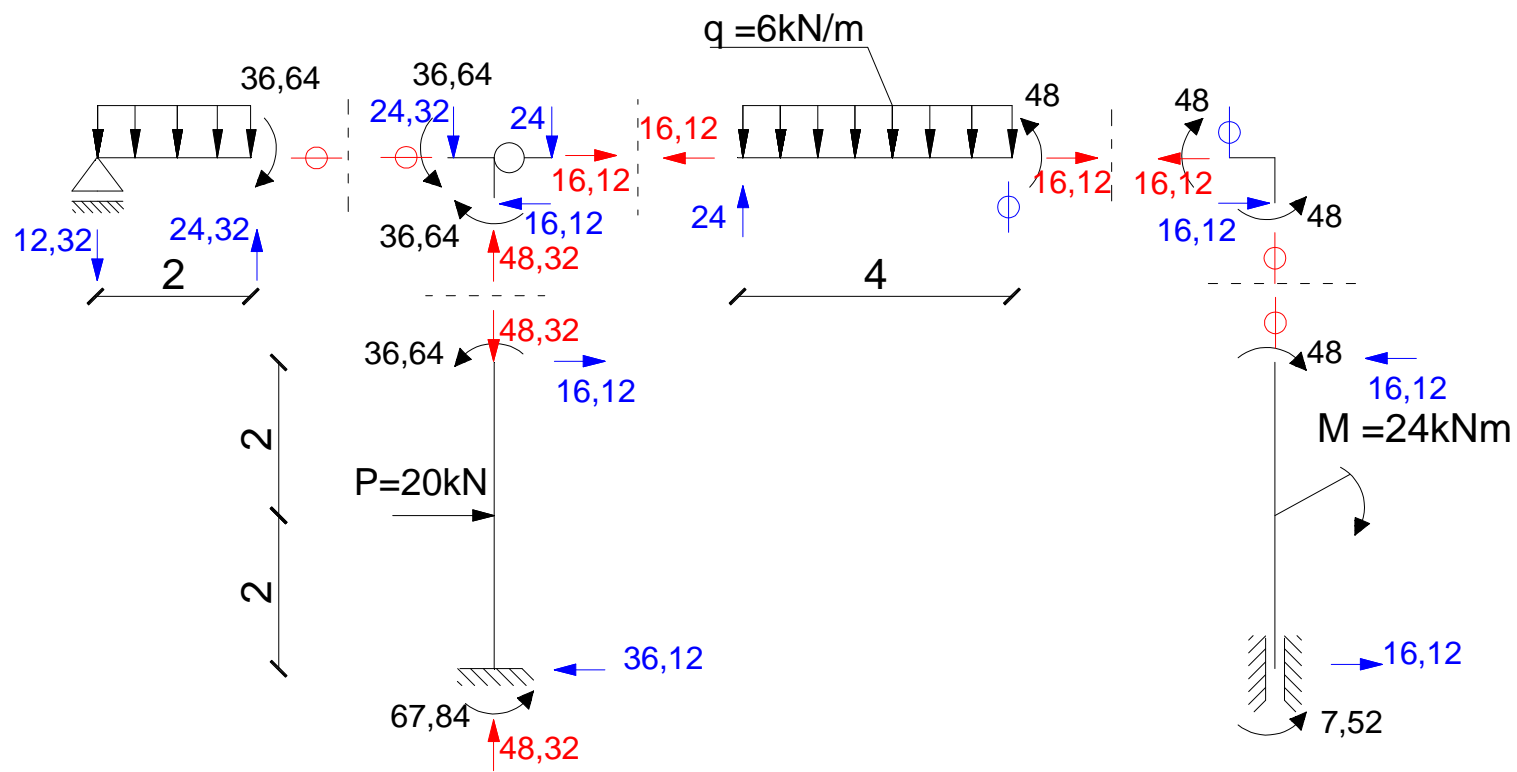

dr inż. Hanna Weber

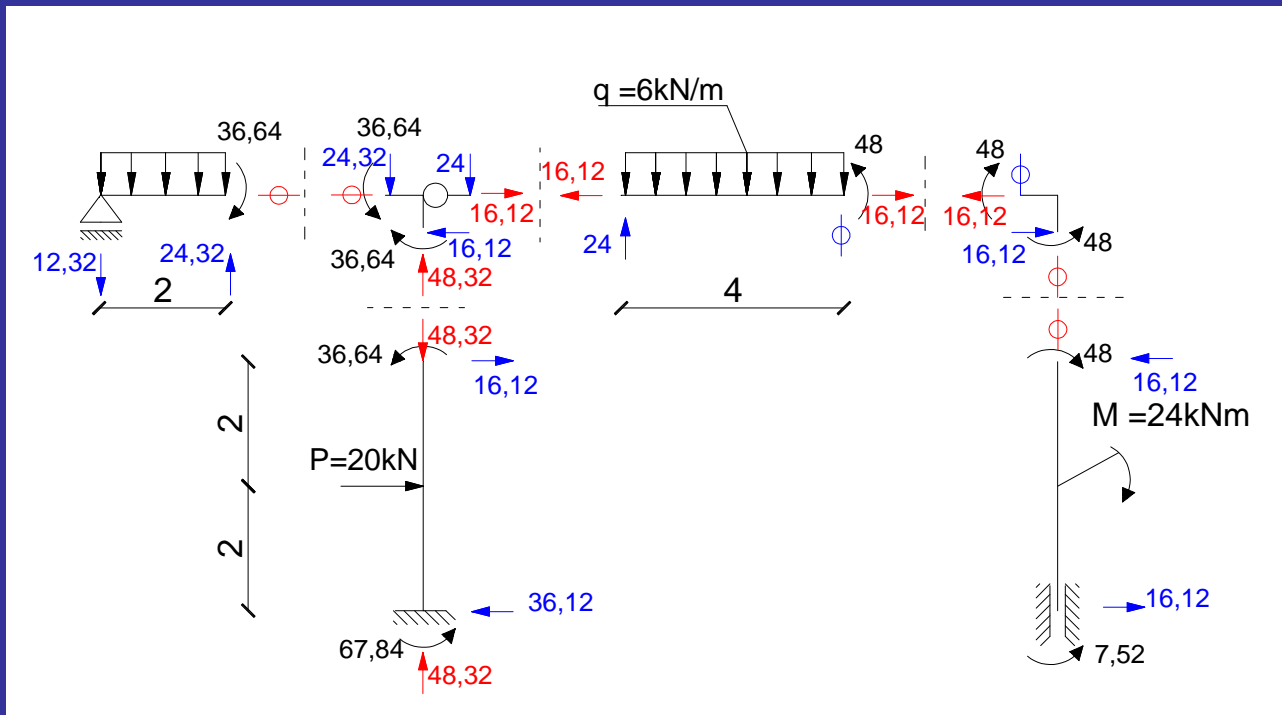

Wykres sił tnących:

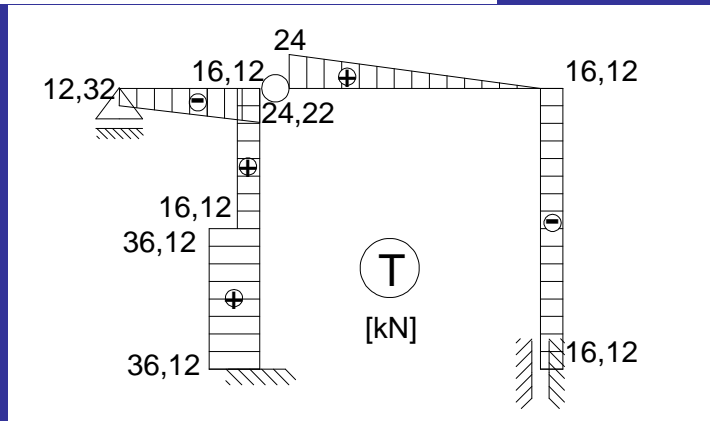

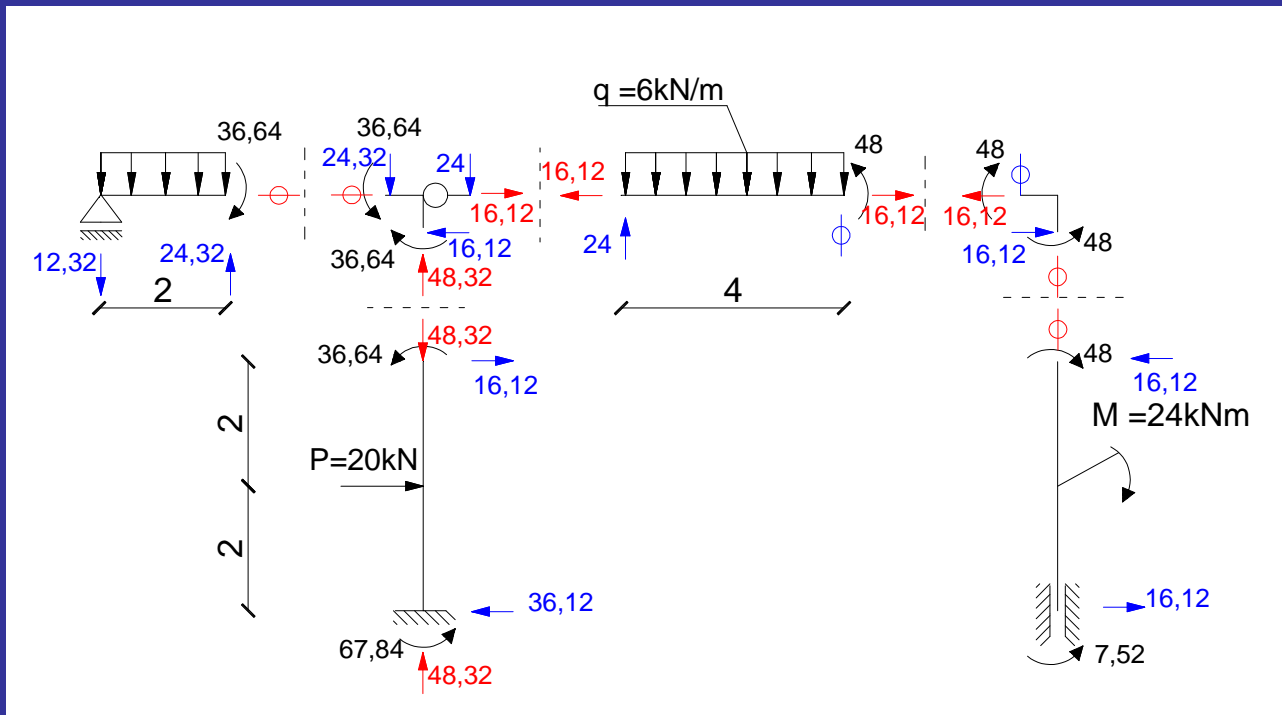

Wykres sił normalnych:

