

Obliczanie ramy przesuwnej metodą przemieszczeń

Zadanie: Narysować wykresy sił M, T i N. Zadanie rozwiązać metodą przemieszczeń w minimalnej bazie niewiadomych.

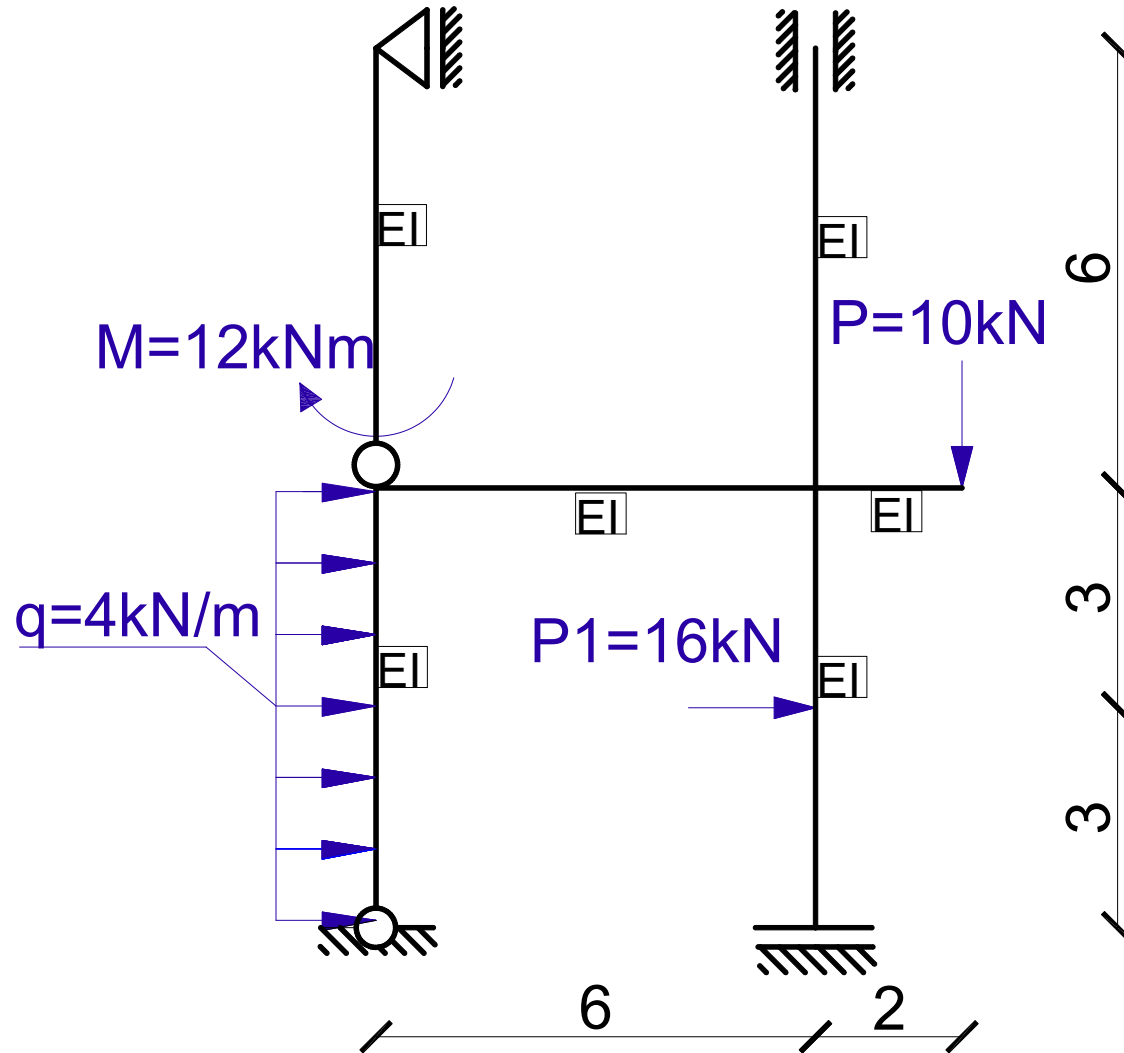

Schemat podstawowy geometrycznie wyznaczalny

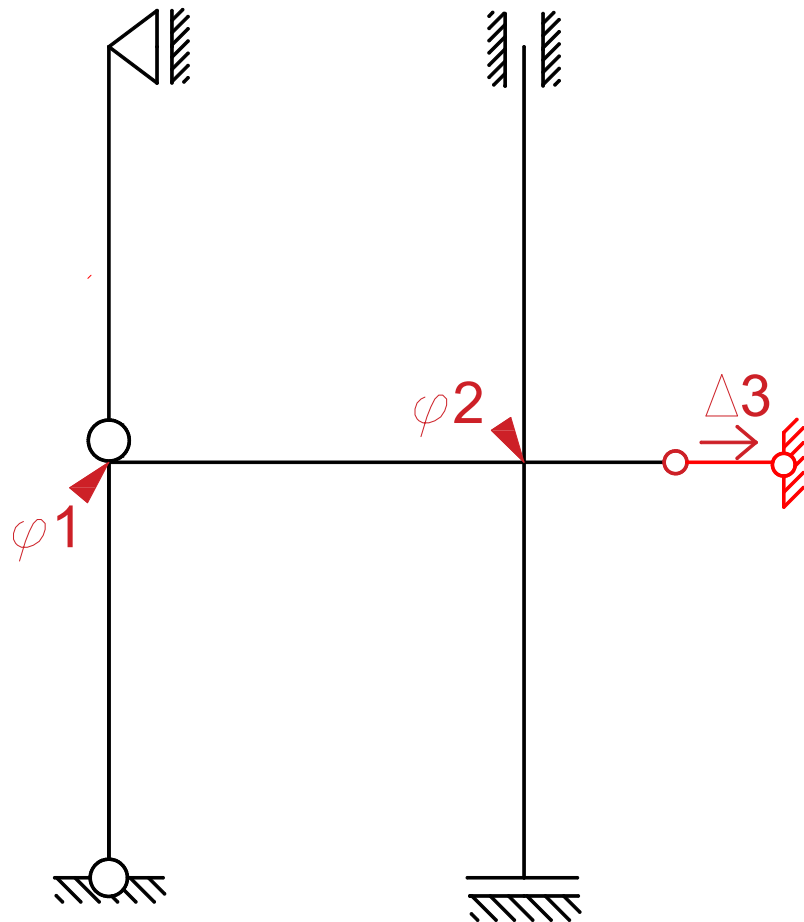

Podział na elementy:

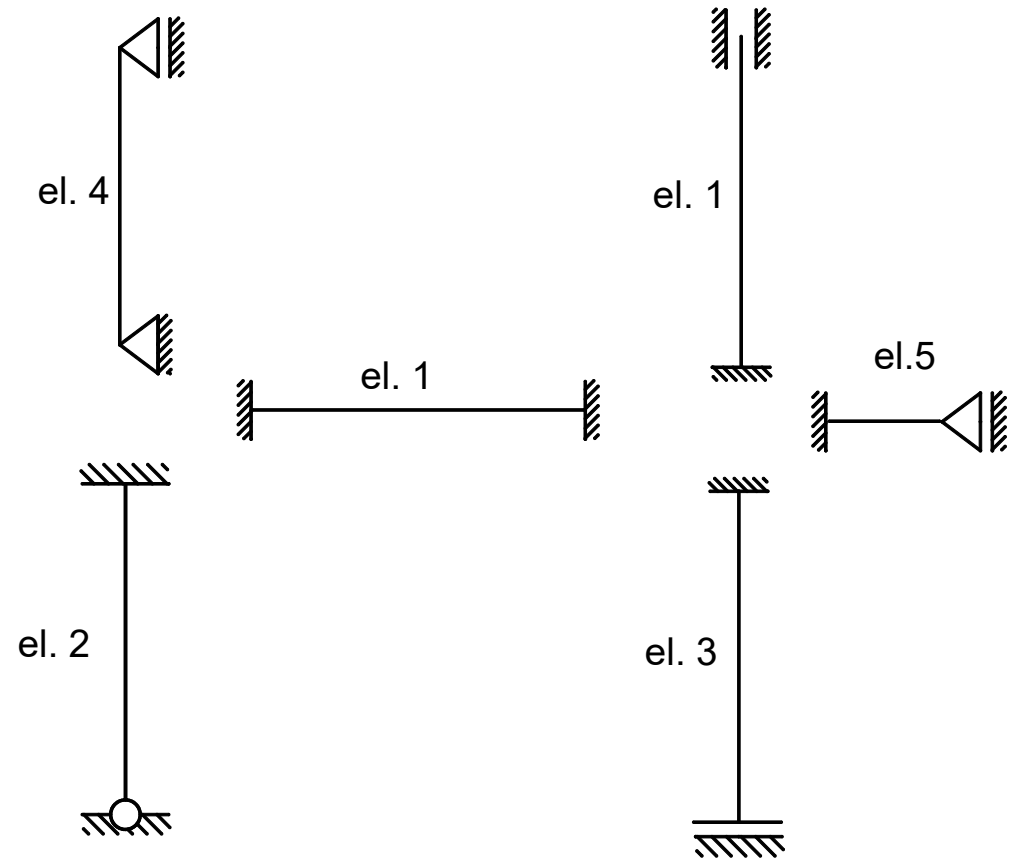

Układ trzykrotnie geometrycznie niewyznaczalny

$$n_g = 3(\varphi 1, \varphi 2, \Delta 3)$$

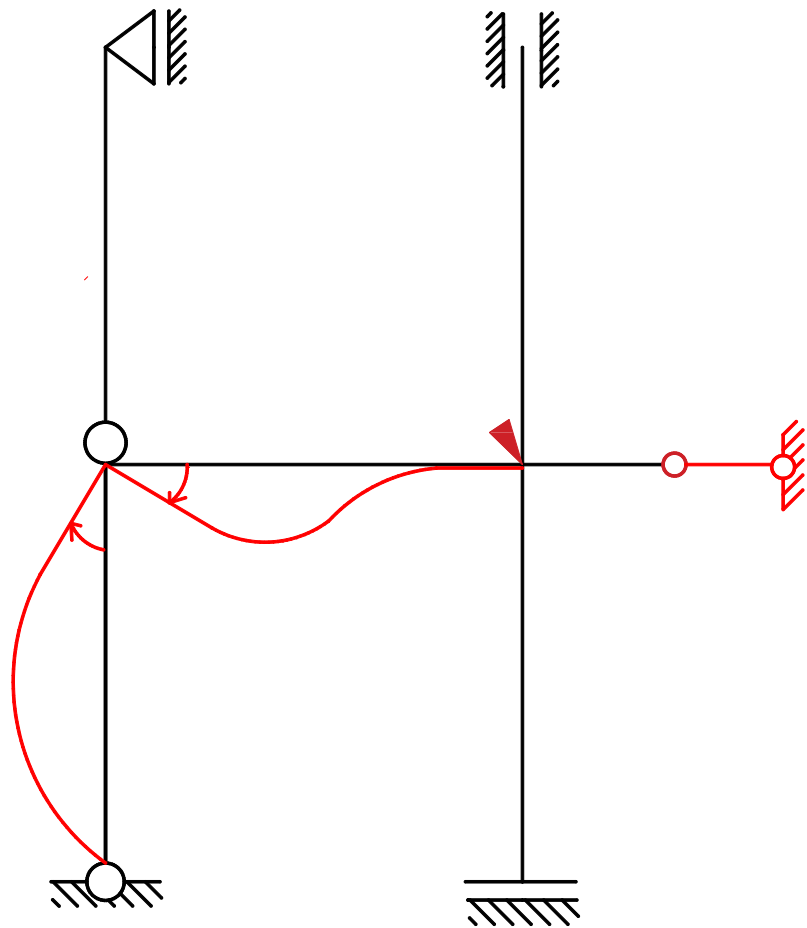

Stan $\varphi_1=1$

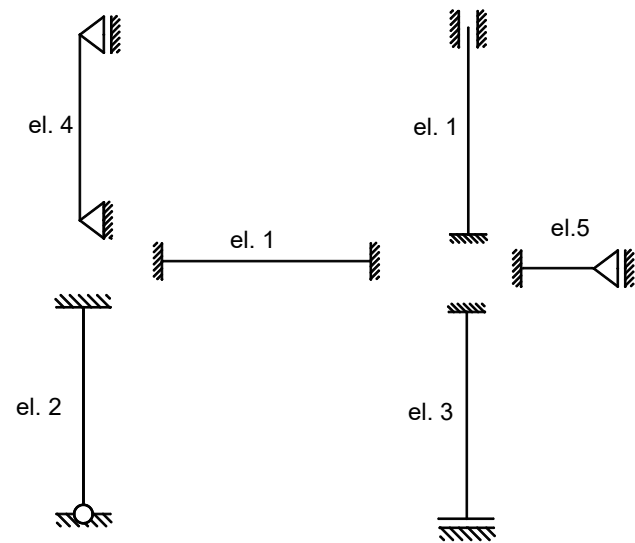

dr inż. Hanna Weber

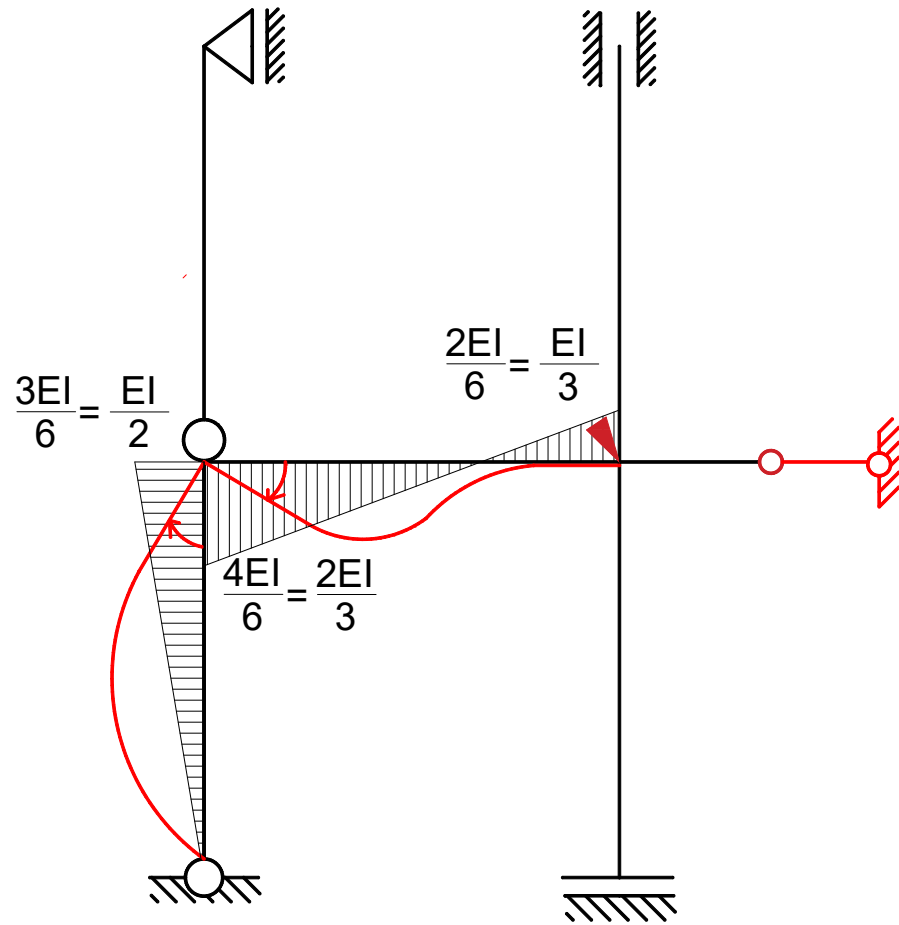

Stan $\varphi_1=1$

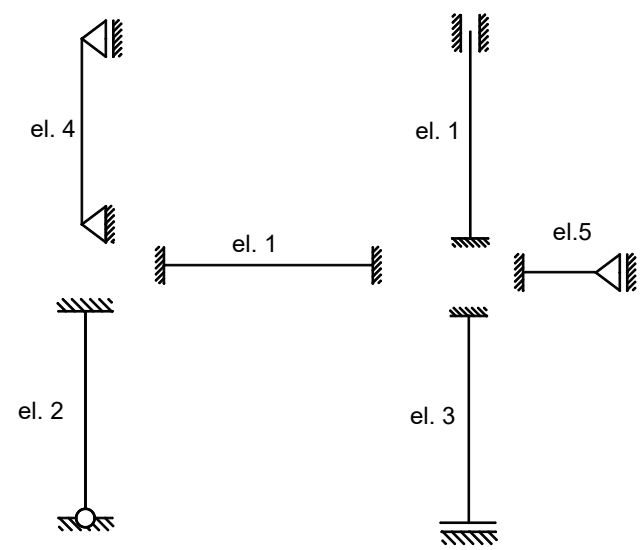

dr inž. Hanna Weber

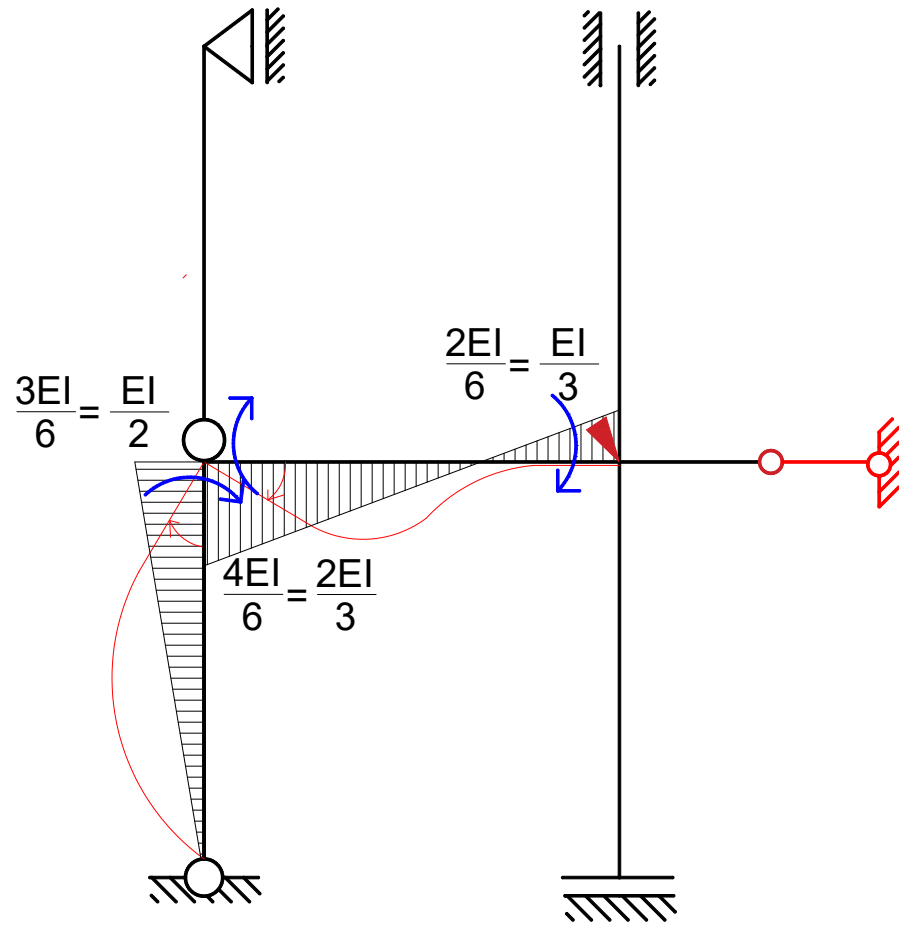

Stan $\varphi_1=1$

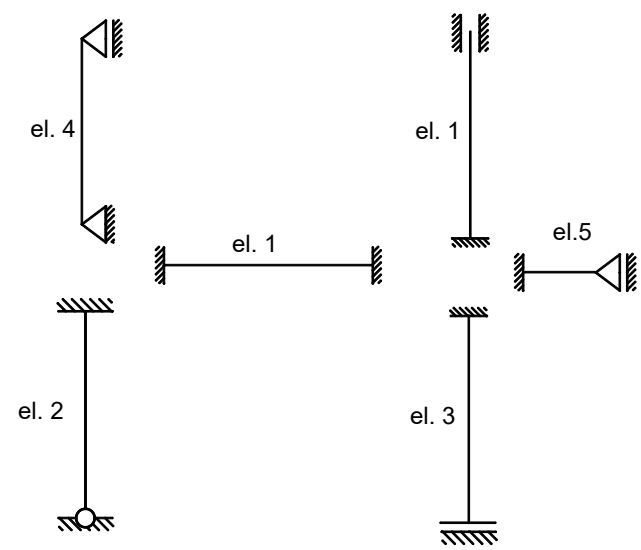

dr inž. Hanna Weber

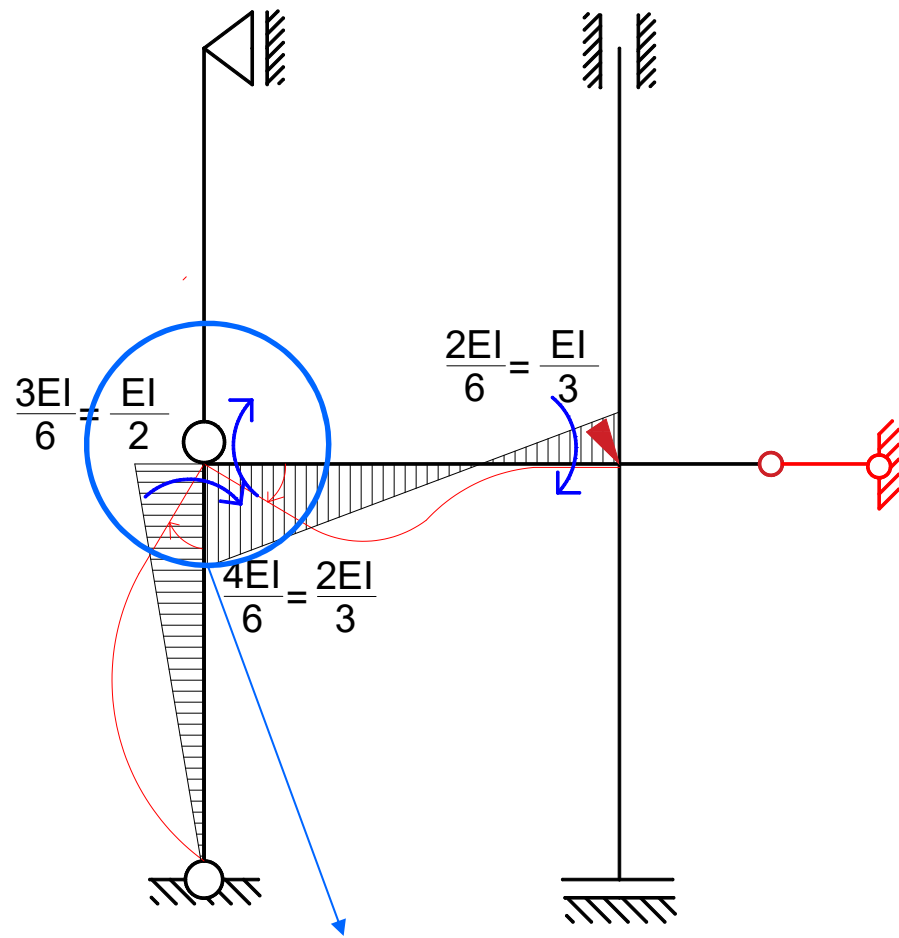

$$k_{11} = \frac{EI}{2} + \frac{2EI}{3} = \frac{7EI}{6}$$

Stan $\varphi_1=1$

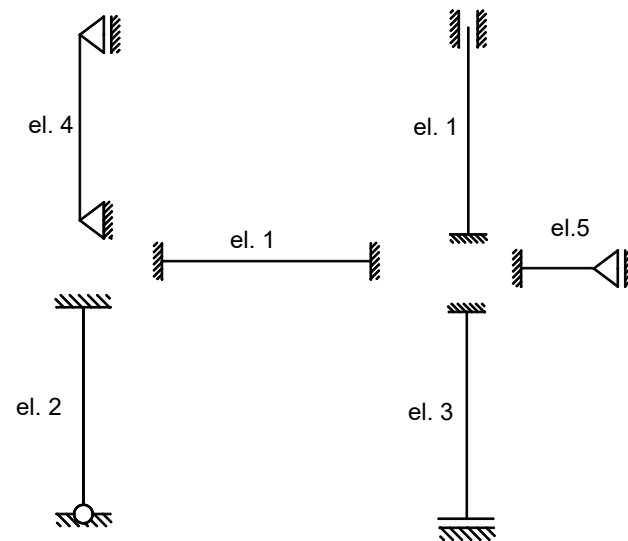

dr inż. Hanna Weber

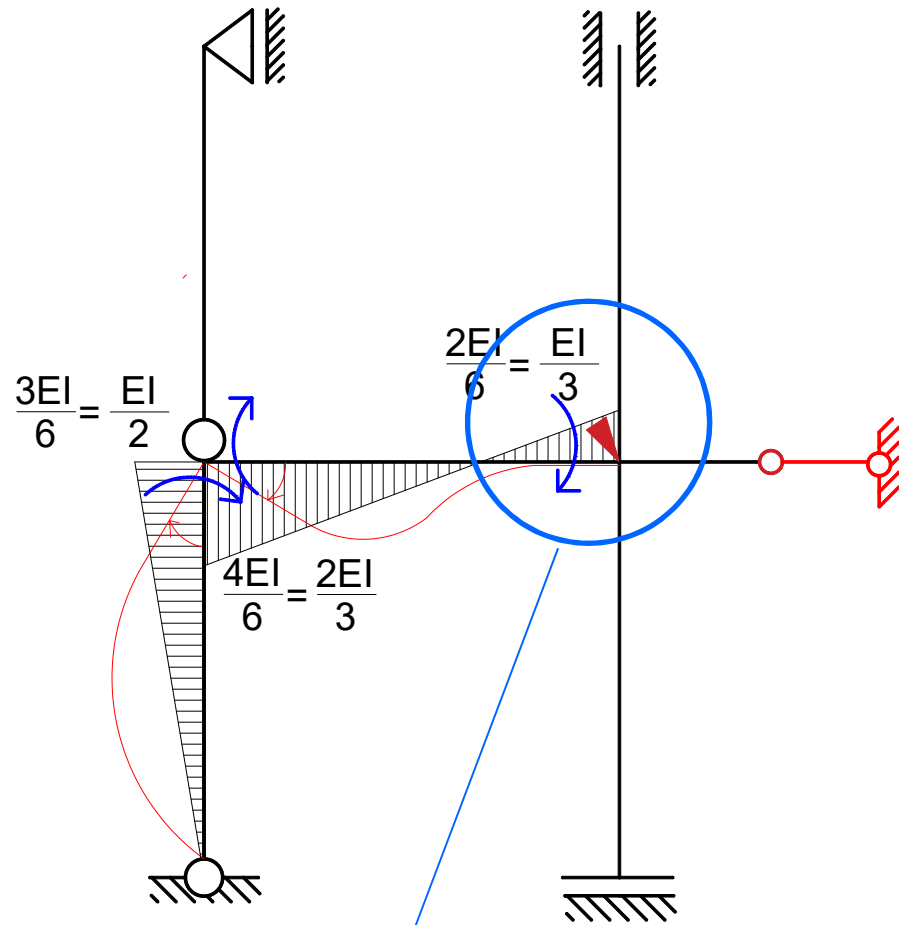

$$k_{11} = \frac{EI}{2} + \frac{2EI}{3} = \frac{7EI}{6}$$

$$k_{21} = \frac{EI}{3}$$

Stan $\varphi_1=1$

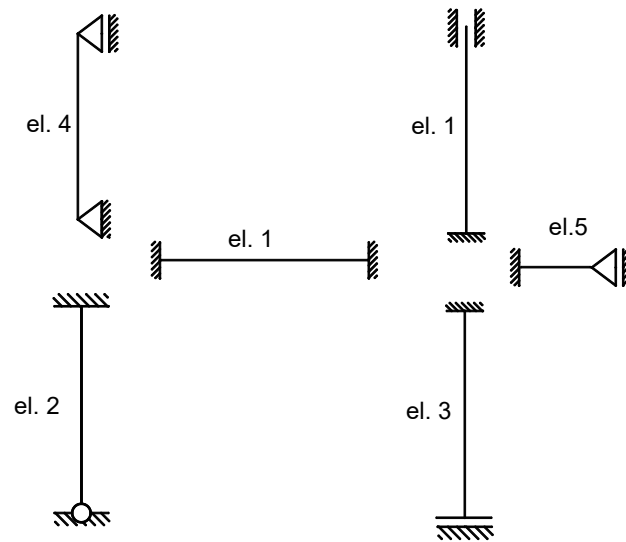

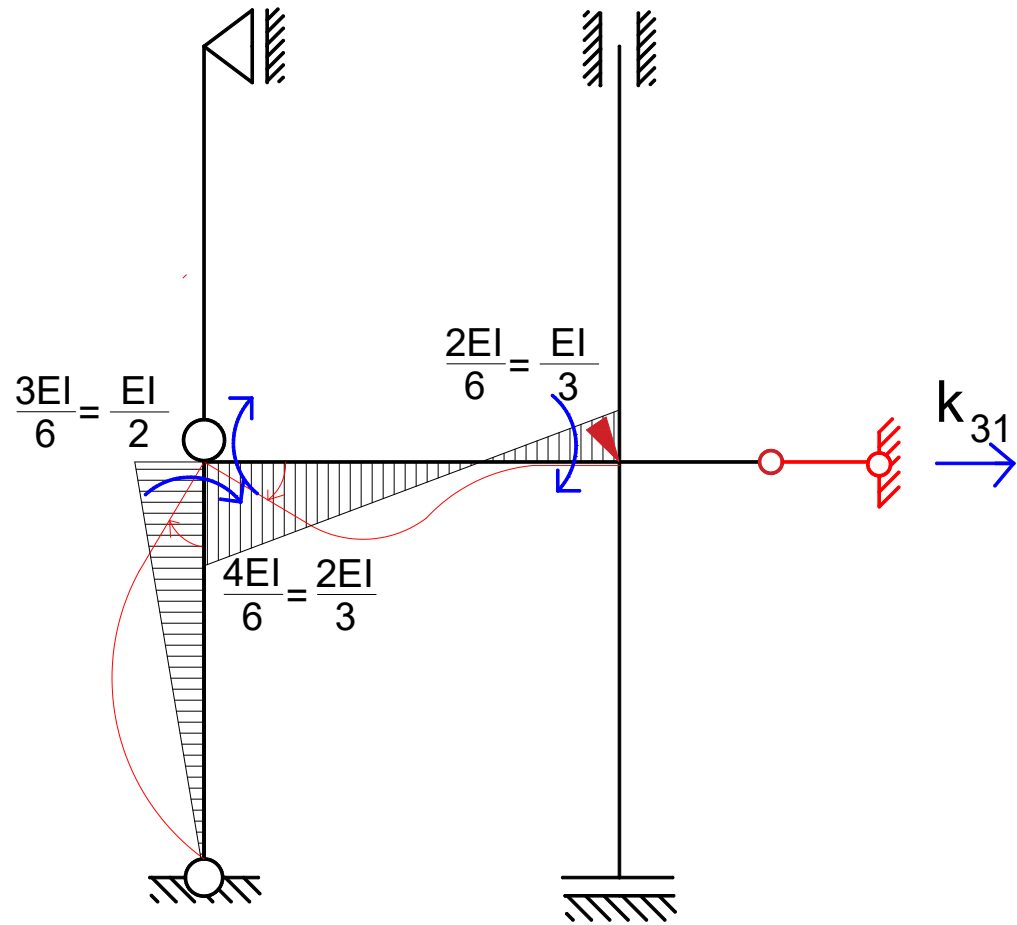

Stan $\varphi_1=1$



$$k_{11} = \frac{EI}{2} + \frac{2EI}{3} = \frac{7EI}{6}$$

$$k_{21} = \frac{EI}{3}$$

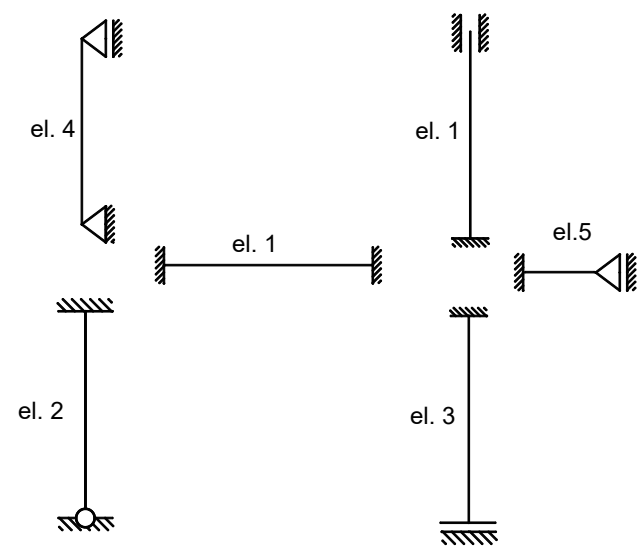

Stan $\varphi_1=1$

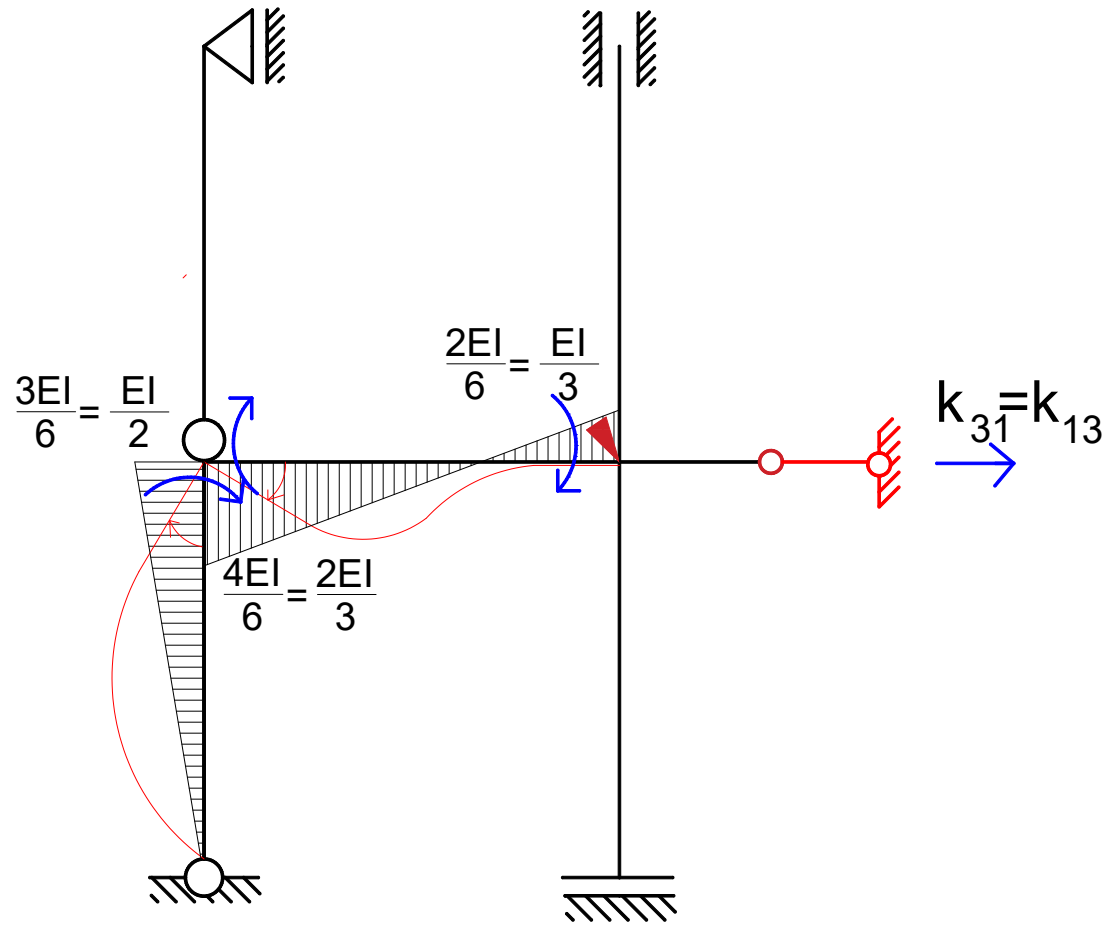

$$k_{11} = \frac{EI}{2} + \frac{2EI}{3} = \frac{7EI}{6}$$

$$k_{21} = \frac{EI}{3}$$

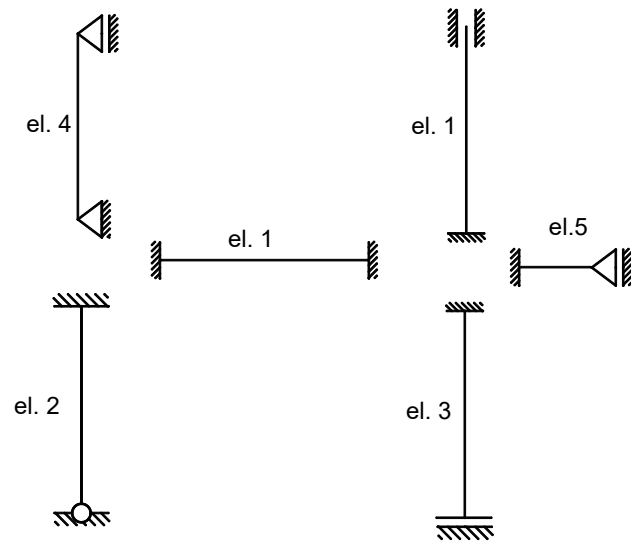

dr inž. Hanna Weber

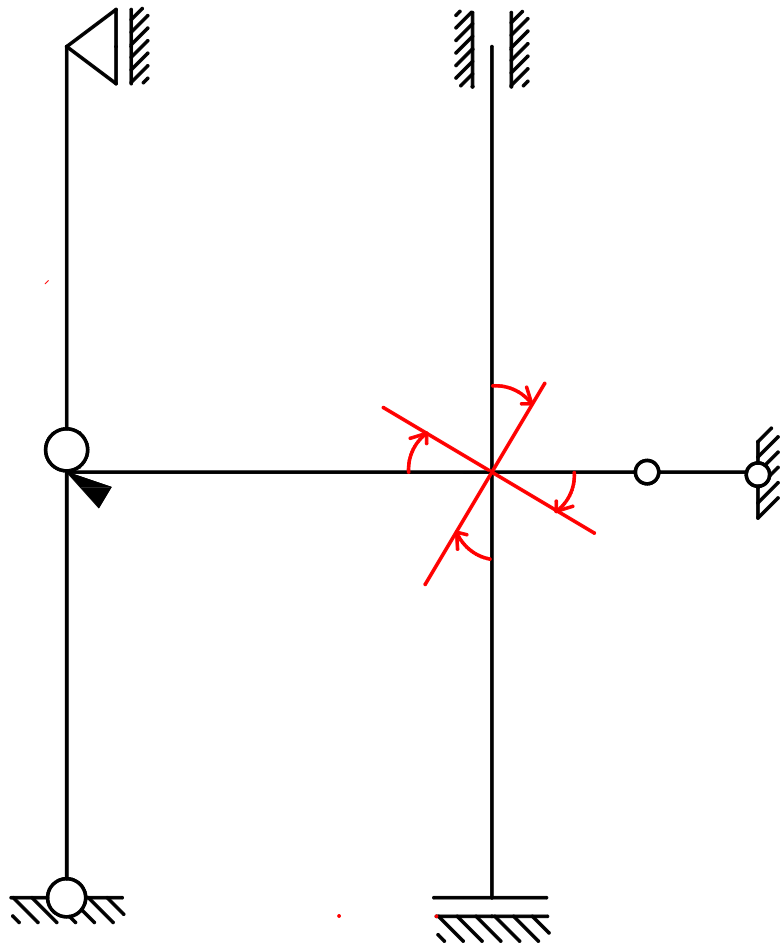

Stan $\varphi_2=1$

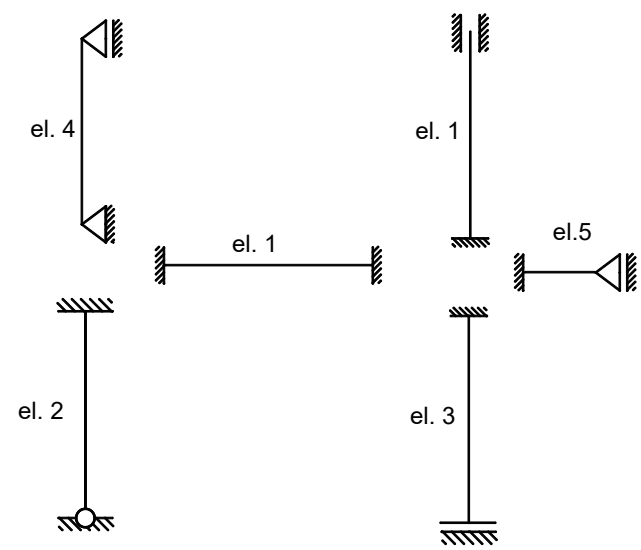

dr inż. Hanna Weber

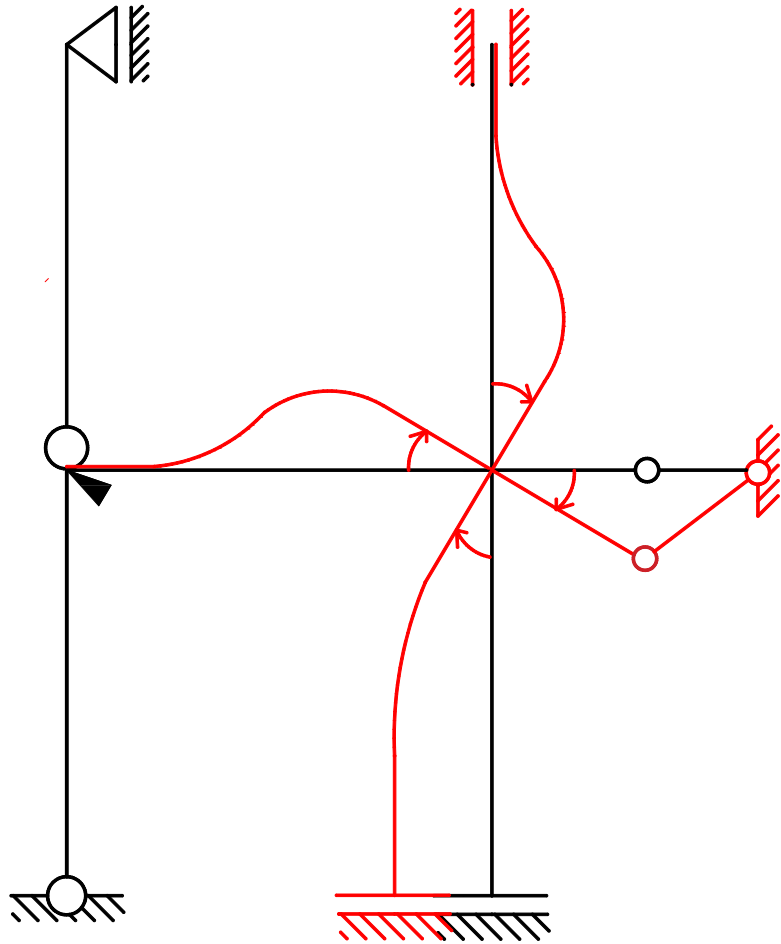

Stan $\varphi_2=1$

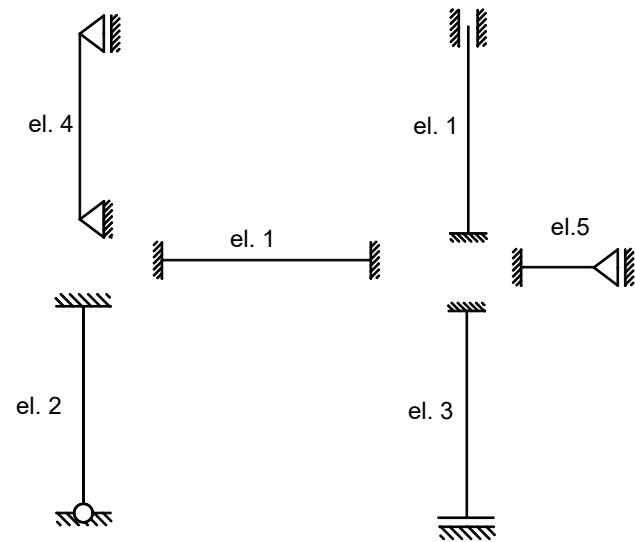

dr inż. Hanna Weber

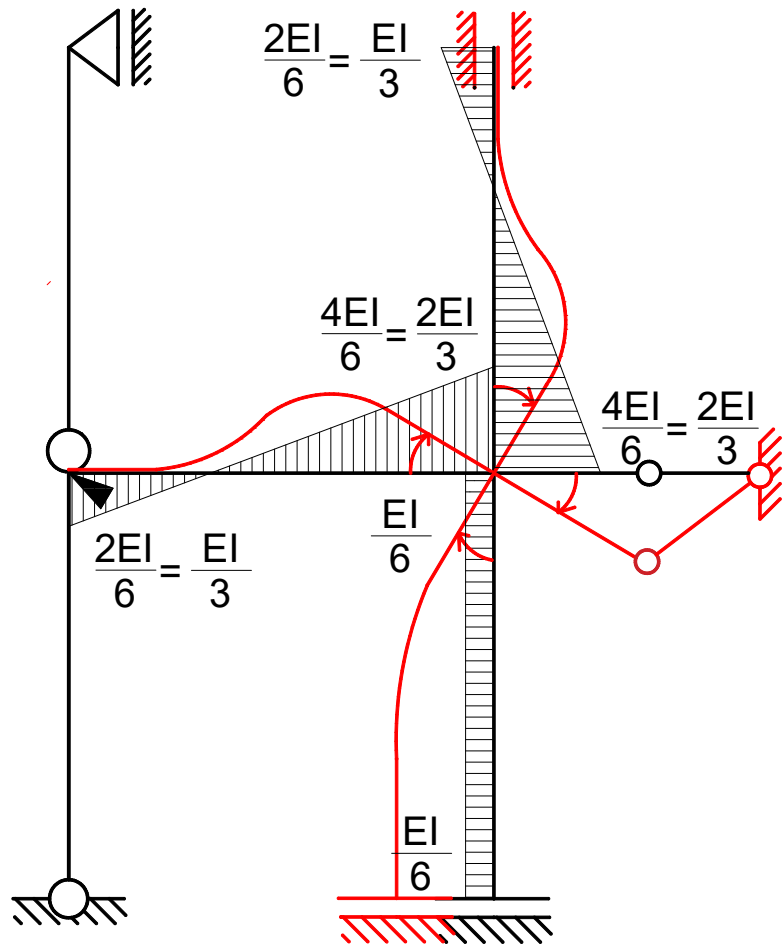

Stan $\varphi_2=1$

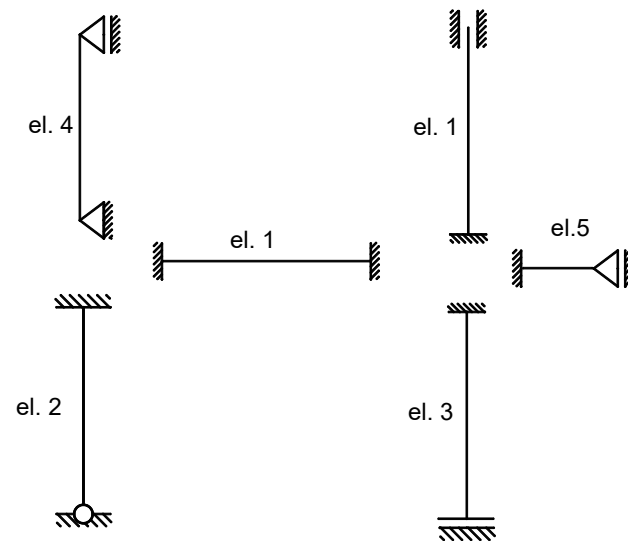

dr inż. Hanna Weber

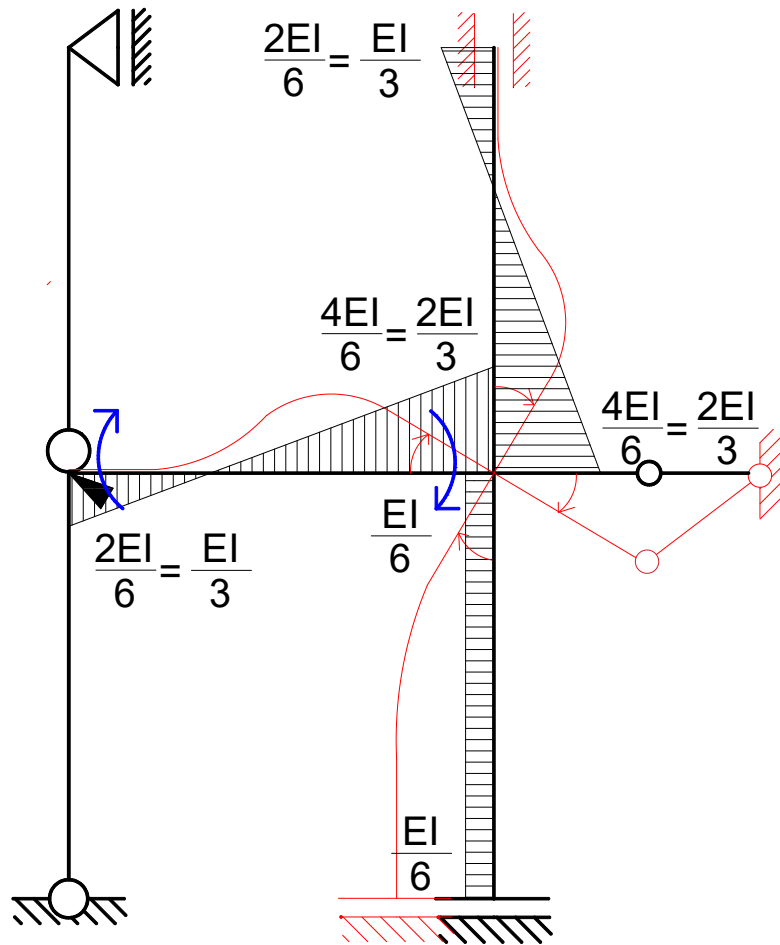

Stan $\varphi_2=1$

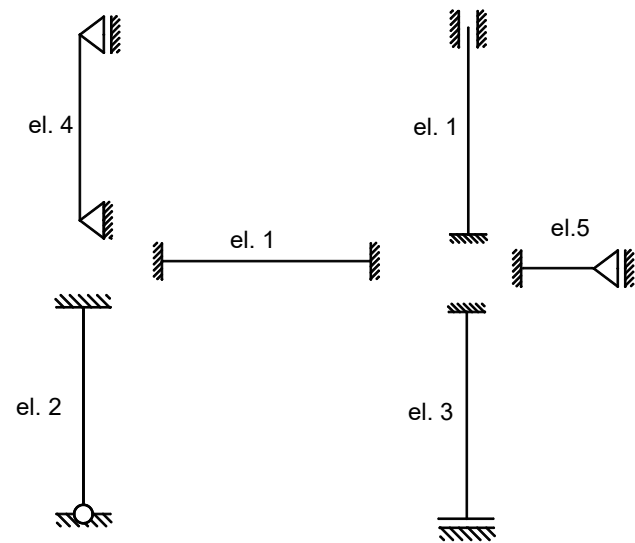

dr inż. Hanna Weber

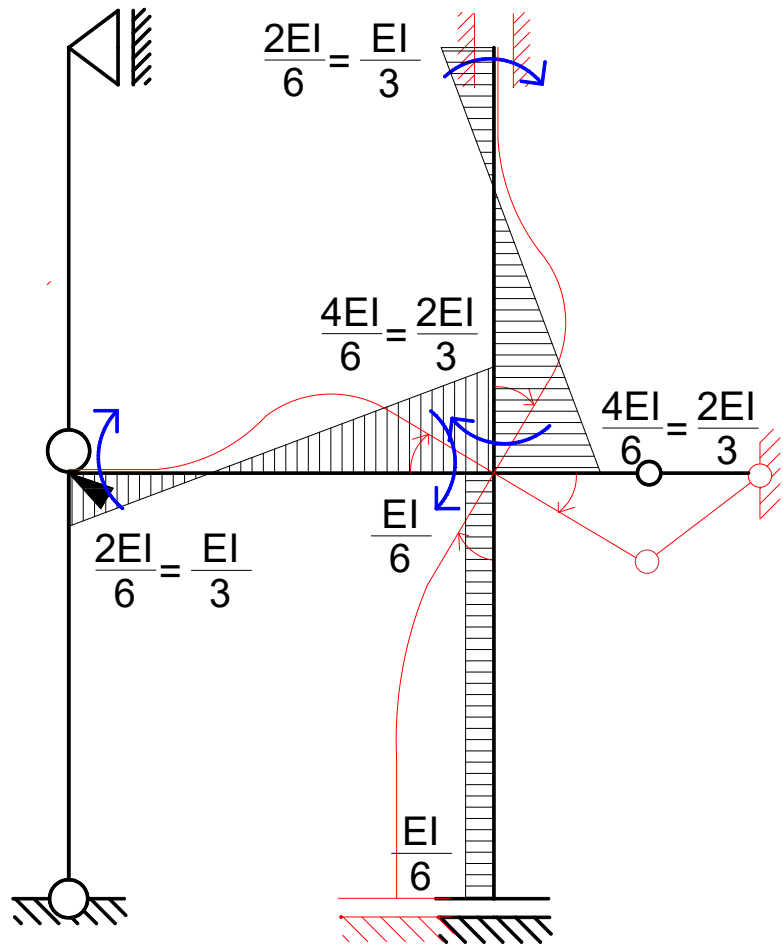

Stan $\varphi_2=1$

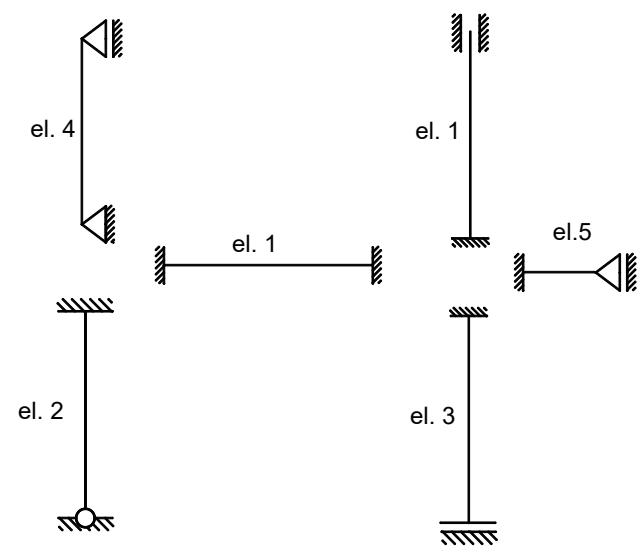

dr inž. Hanna Weber

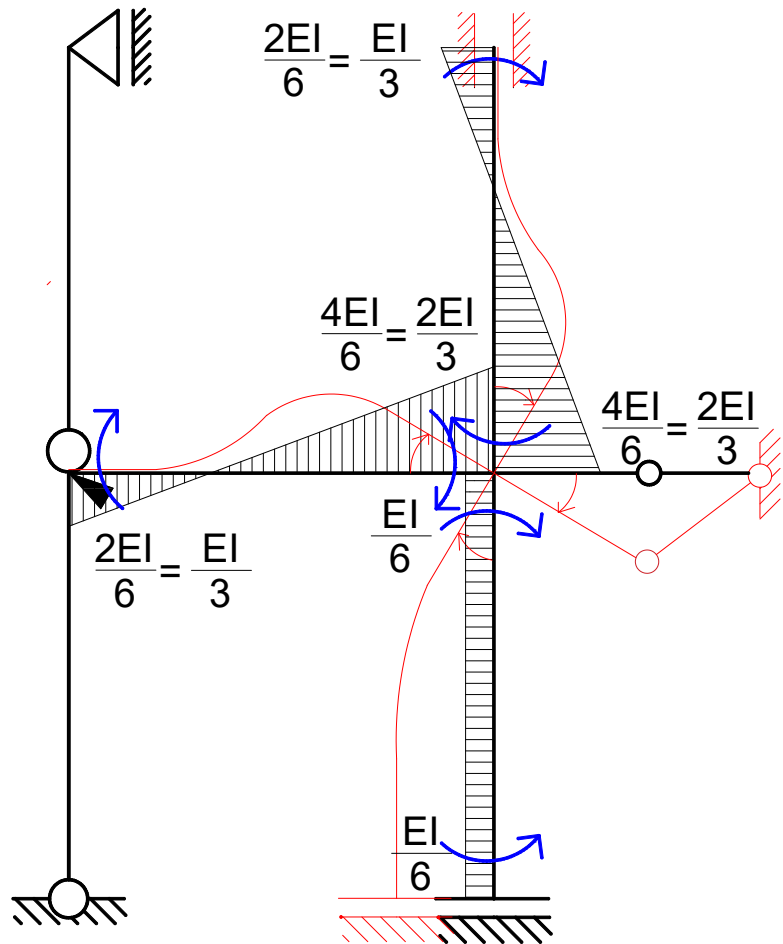

Stan $\varphi_2=1$

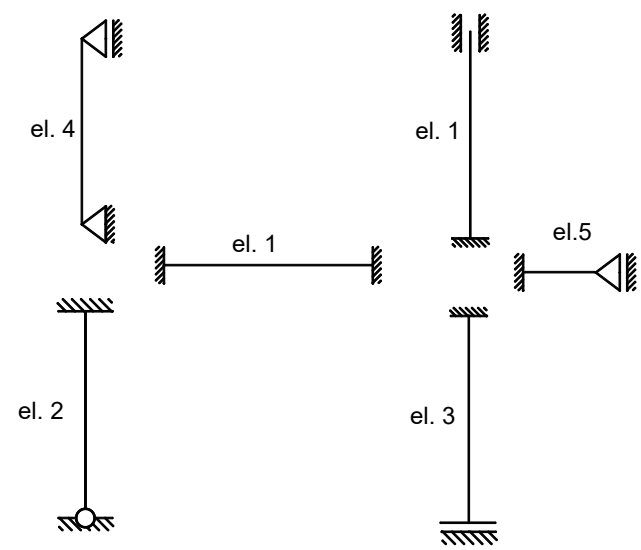

dr inž. Hanna Weber

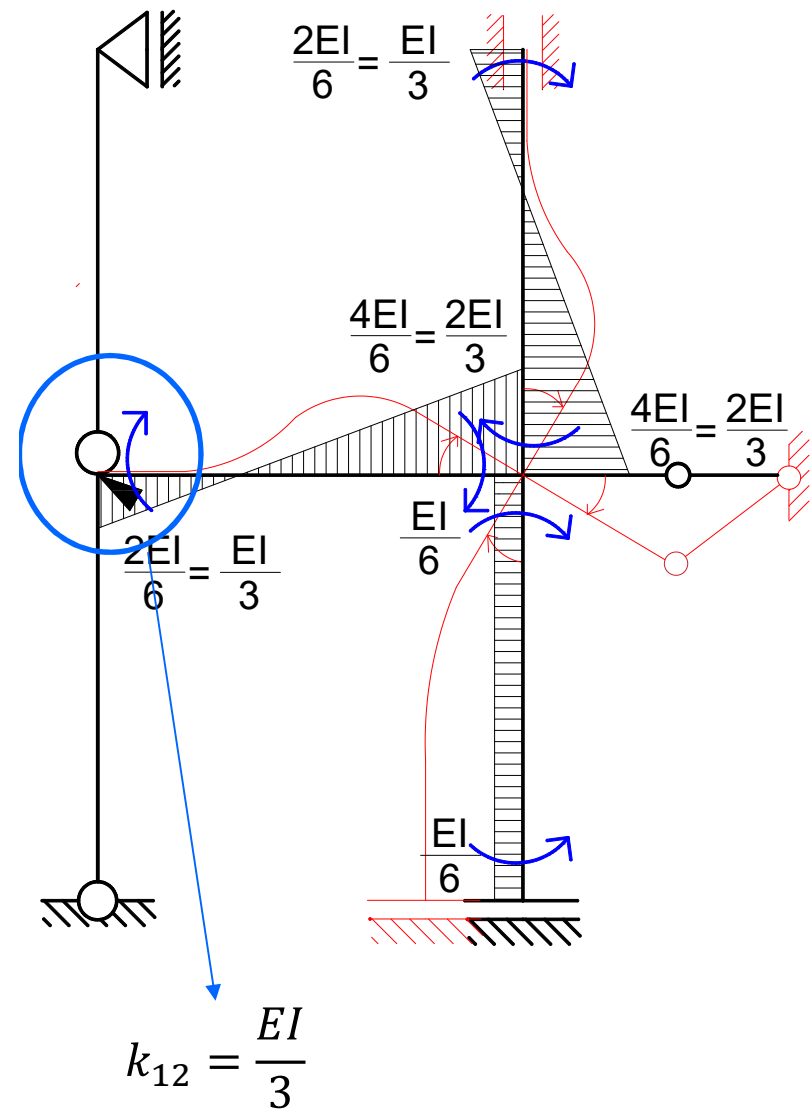

Stan $\varphi_2=1$

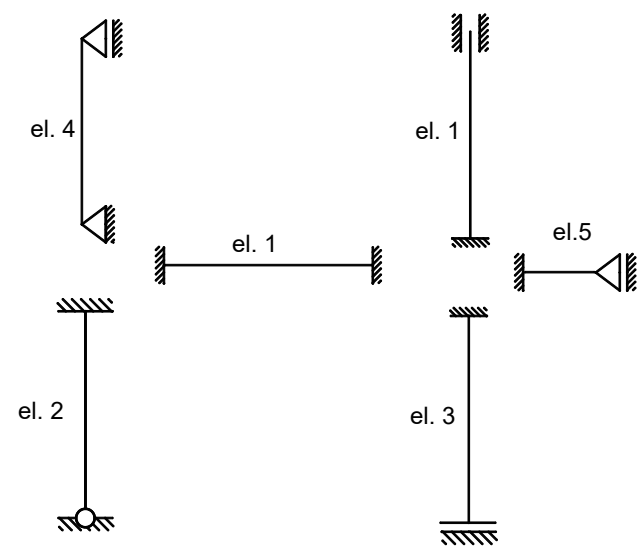

dr inż. Hanna Weber

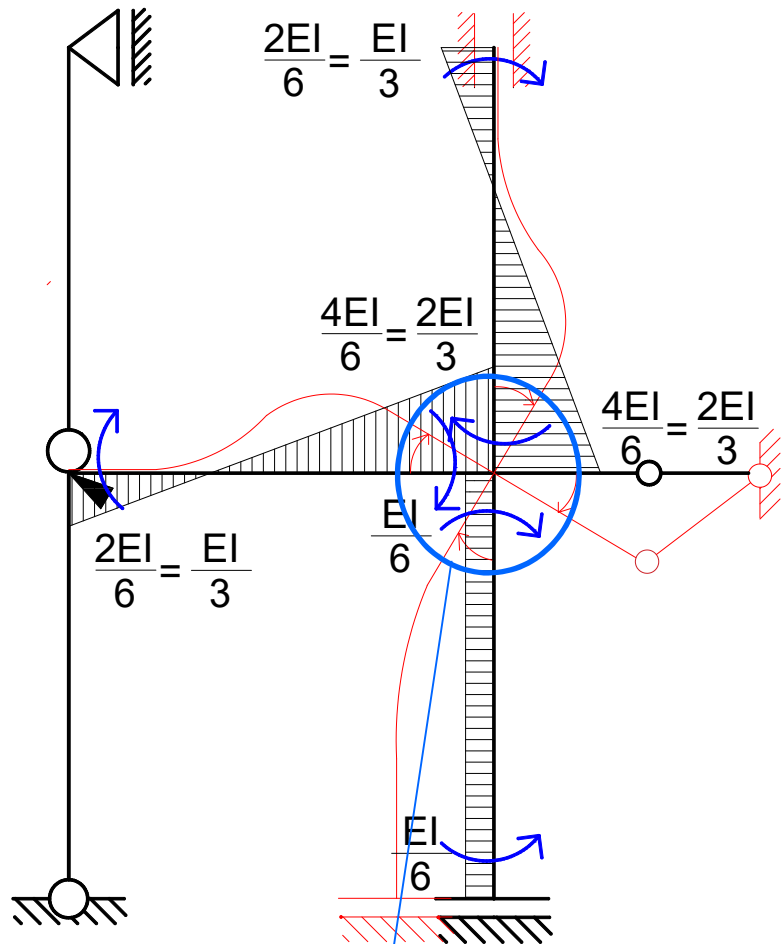

$$k_{12} = \frac{EI}{3}$$

$$k_{22} = \frac{2EI}{3} + \frac{2EI}{3} + \frac{EI}{6} = \frac{3EI}{2}$$

Stan $\varphi_2=1$

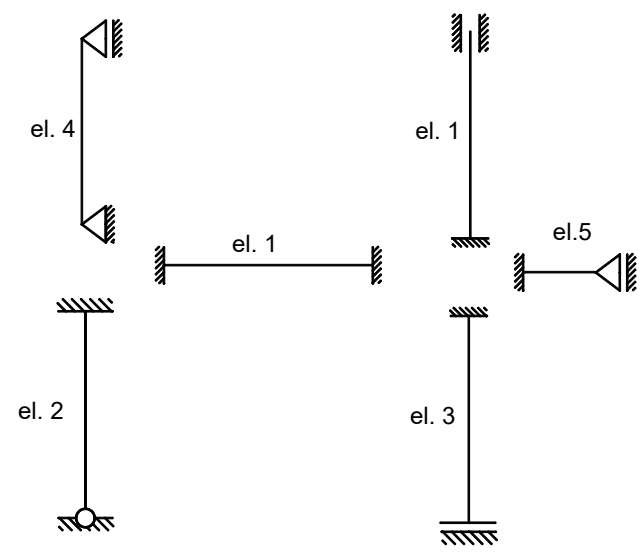

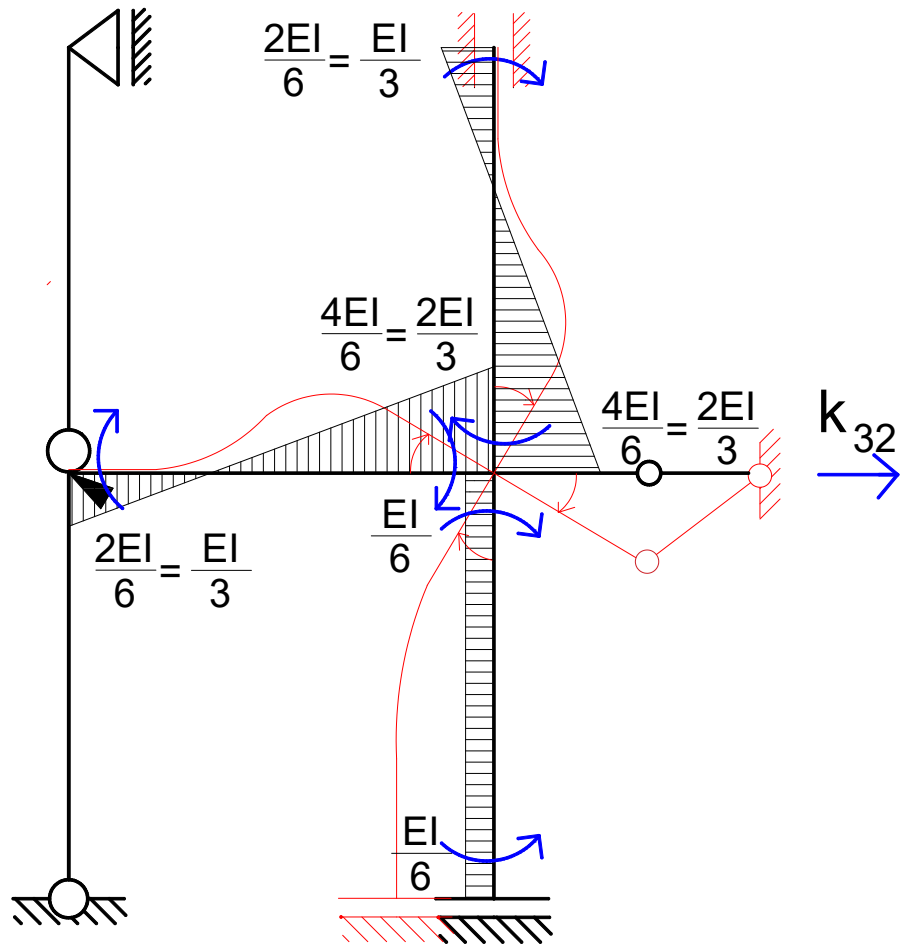

$$k_{12} = \frac{EI}{3}$$

$$k_{22} = \frac{2EI}{3} + \frac{2EI}{3} + \frac{EI}{6} = \frac{3EI}{2}$$

Stan $\varphi_2=1$

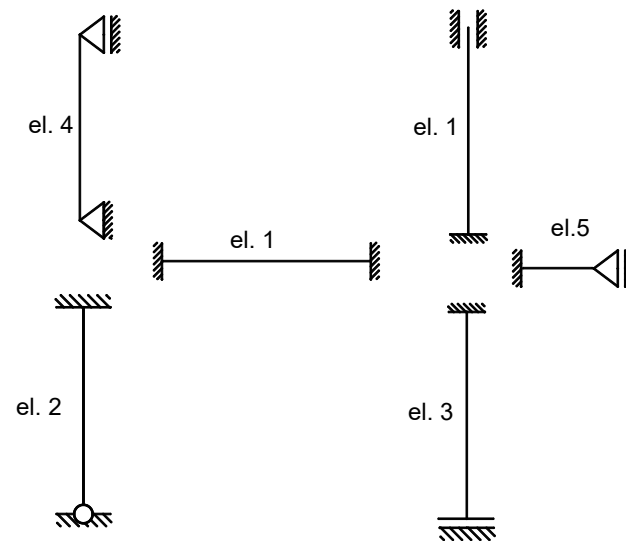

dr inż. Hanna Weber

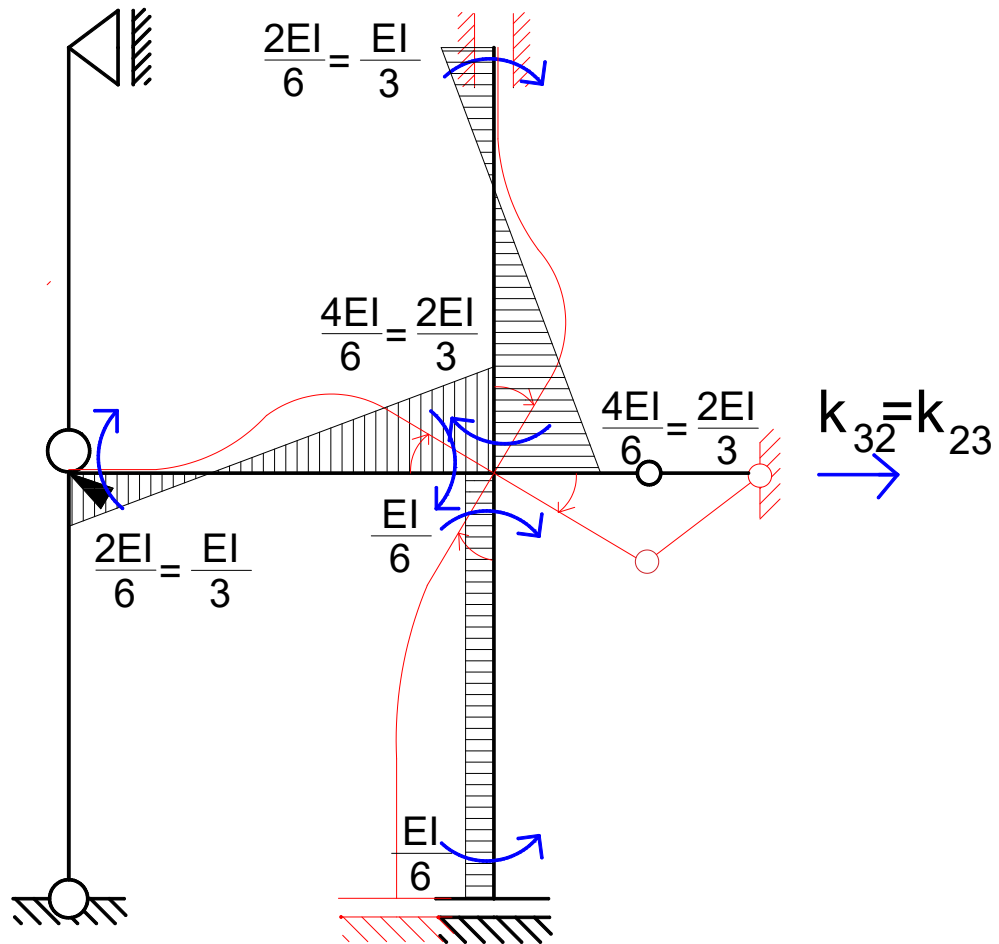

$$k_{12} = \frac{EI}{3}$$

$$k_{22} = \frac{2EI}{3} + \frac{2EI}{3} + \frac{EI}{6} = \frac{3EI}{2}$$

Stan $\varphi_2=1$

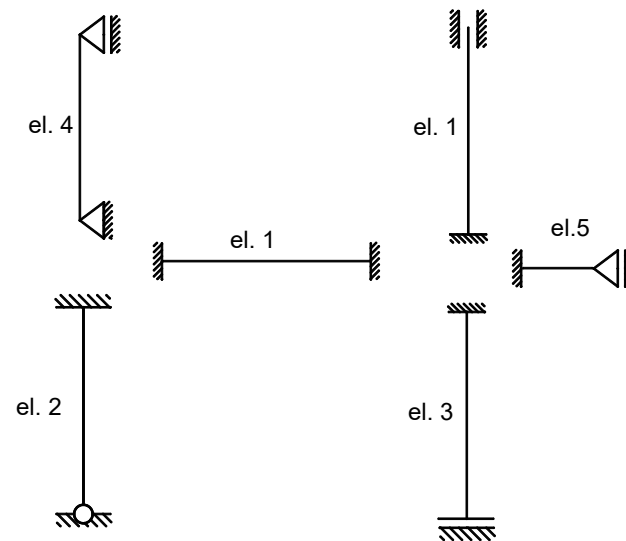

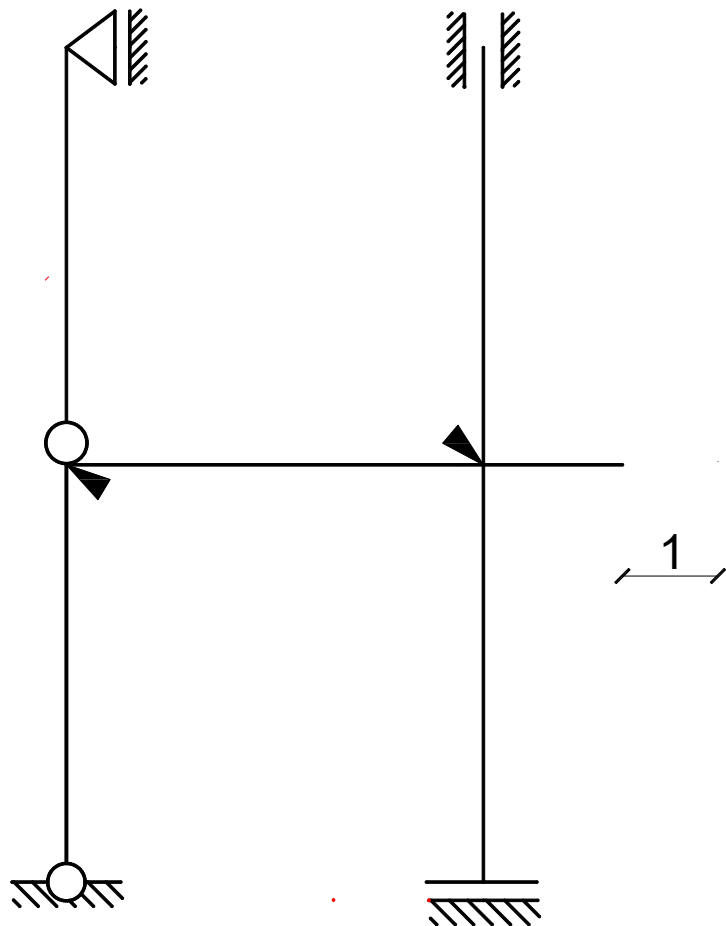

Stan $\Delta_3=1$

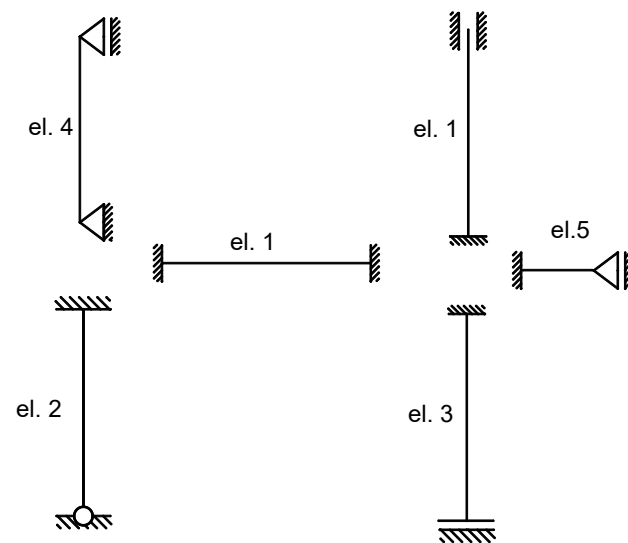

dr inž. Hanna Weber

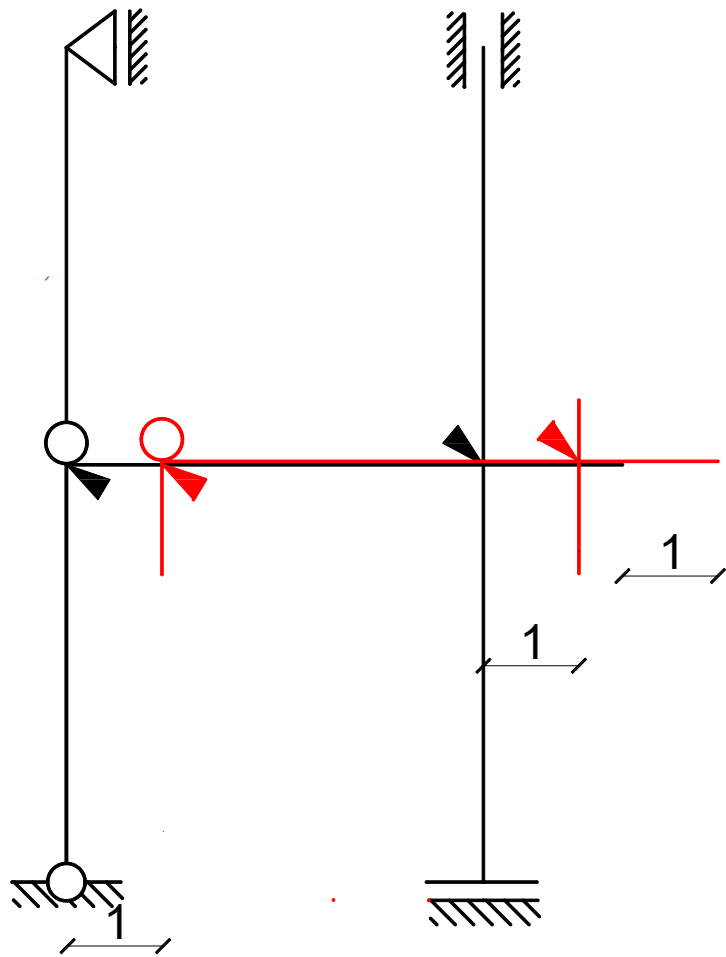

Stan $\Delta_3=1$

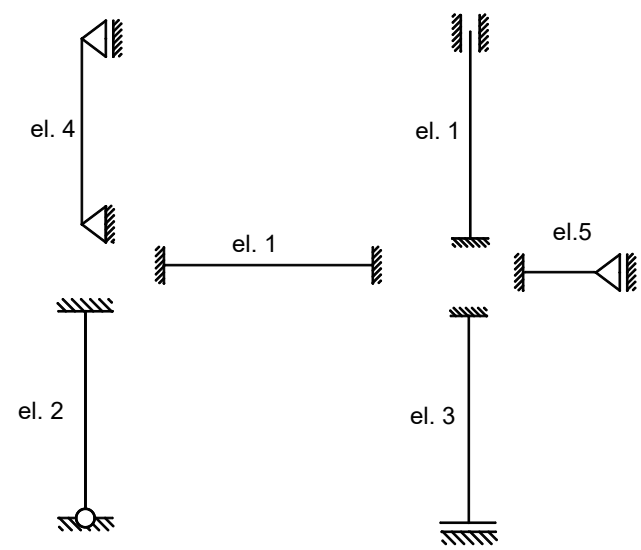

dr inż. Hanna Weber

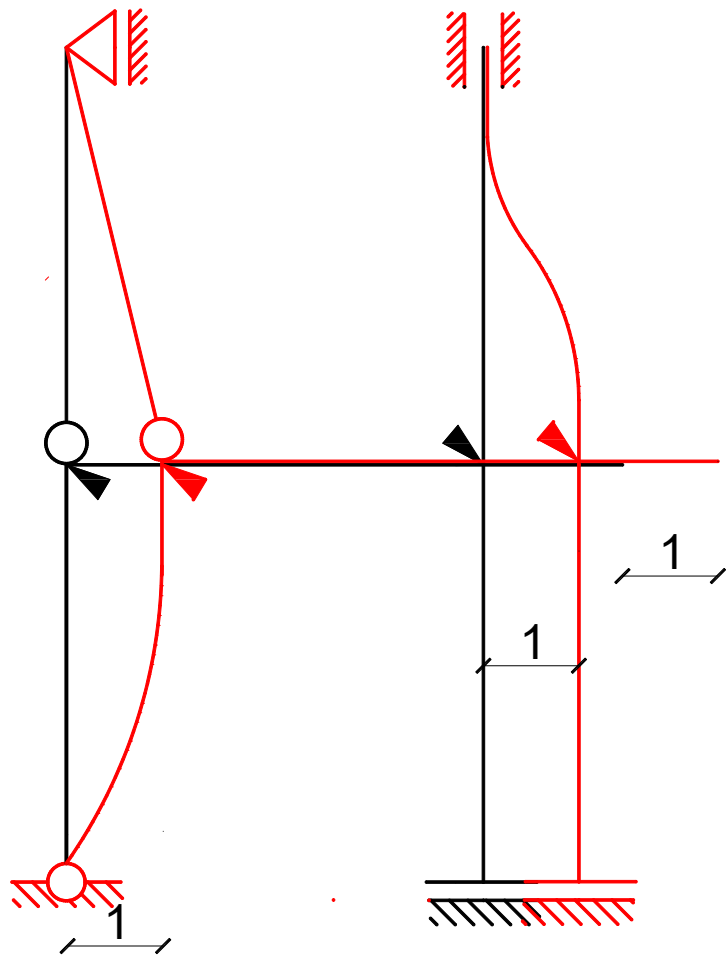

Stan $\Delta_3=1$

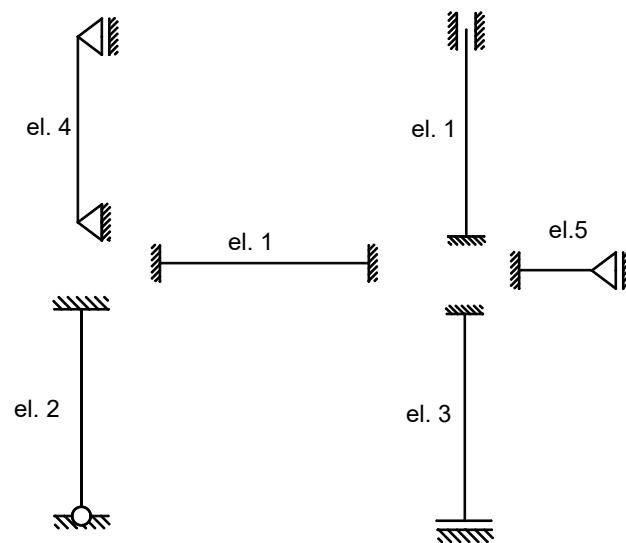

dr inż. Hanna Weber

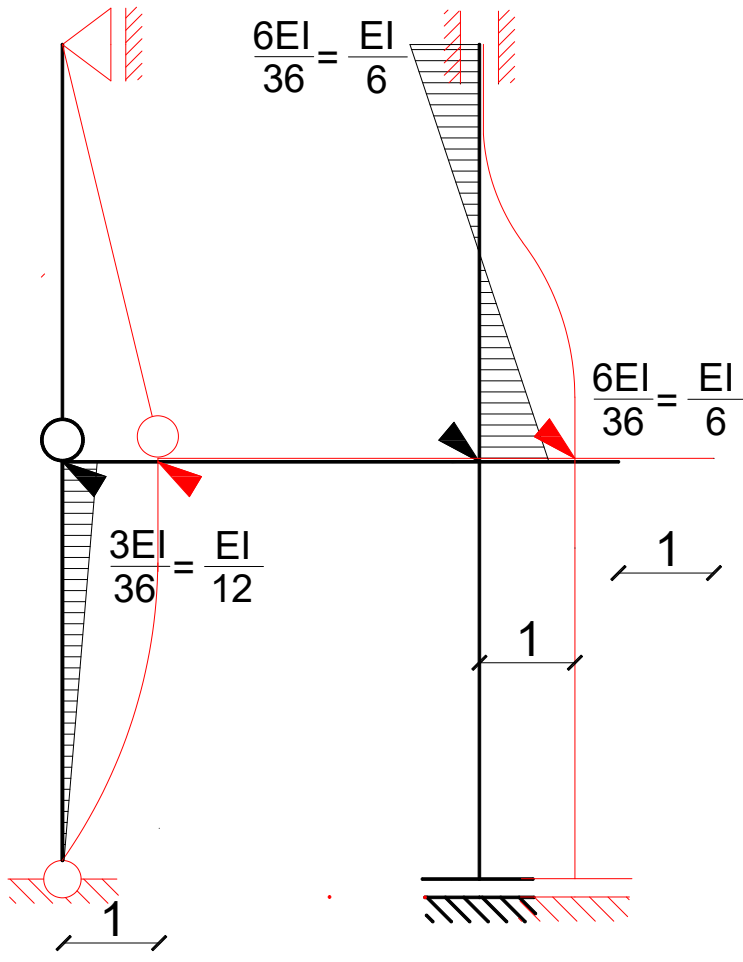

Stan $\Delta_3=1$

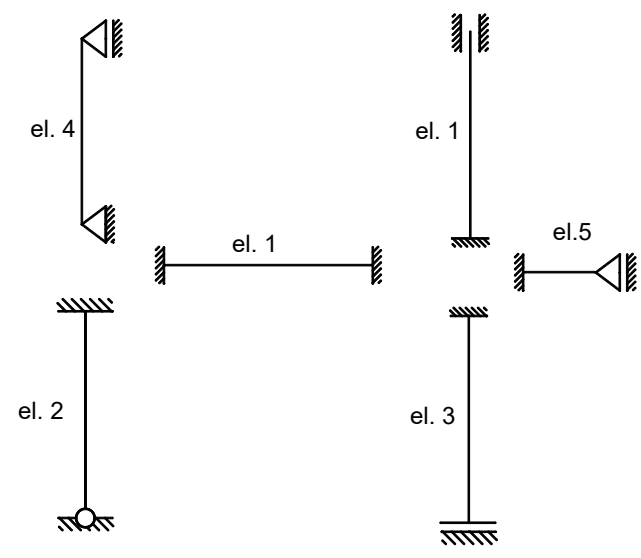

dr inż. Hanna Weber

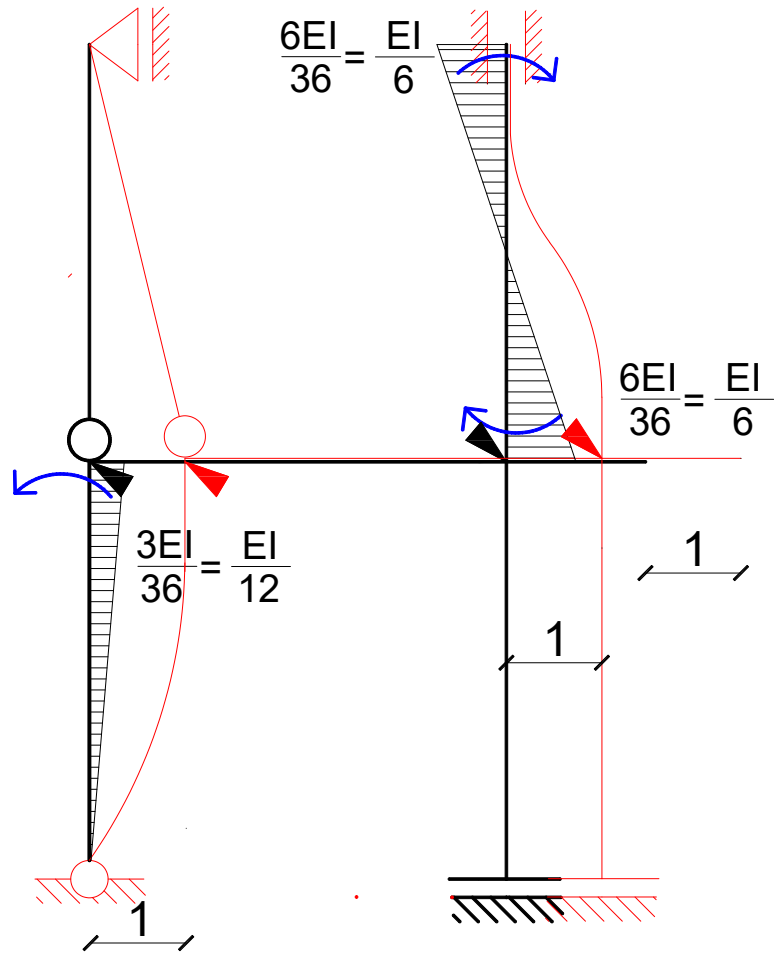

Stan $\Delta_3=1$

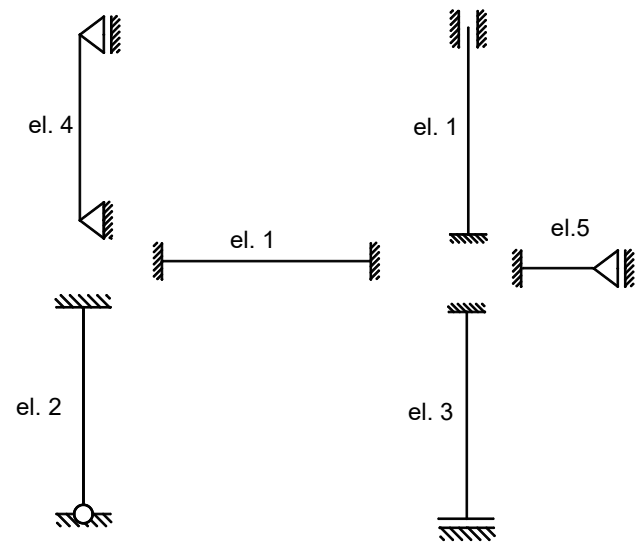

dr inž. Hanna Weber

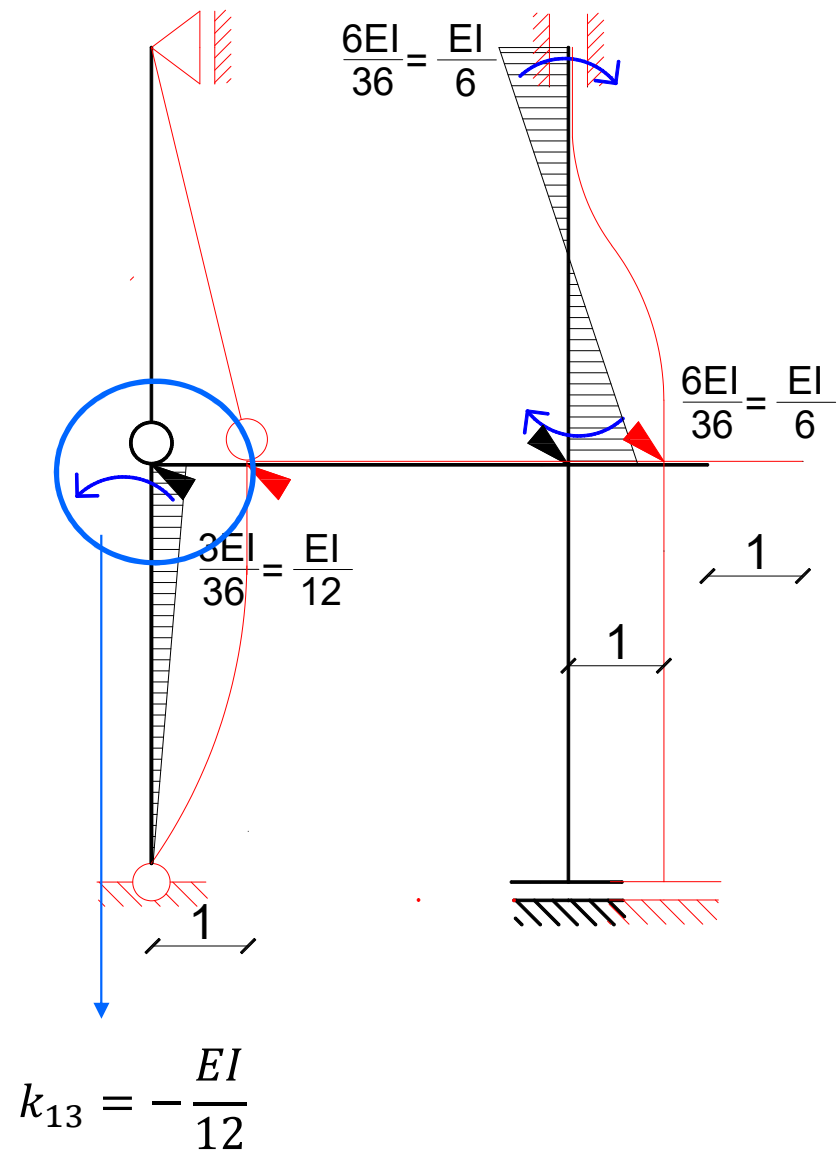

Stan $\Delta_3=1$

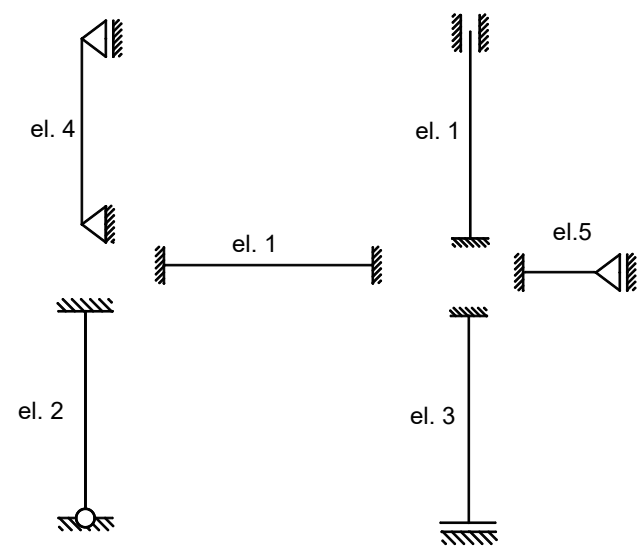

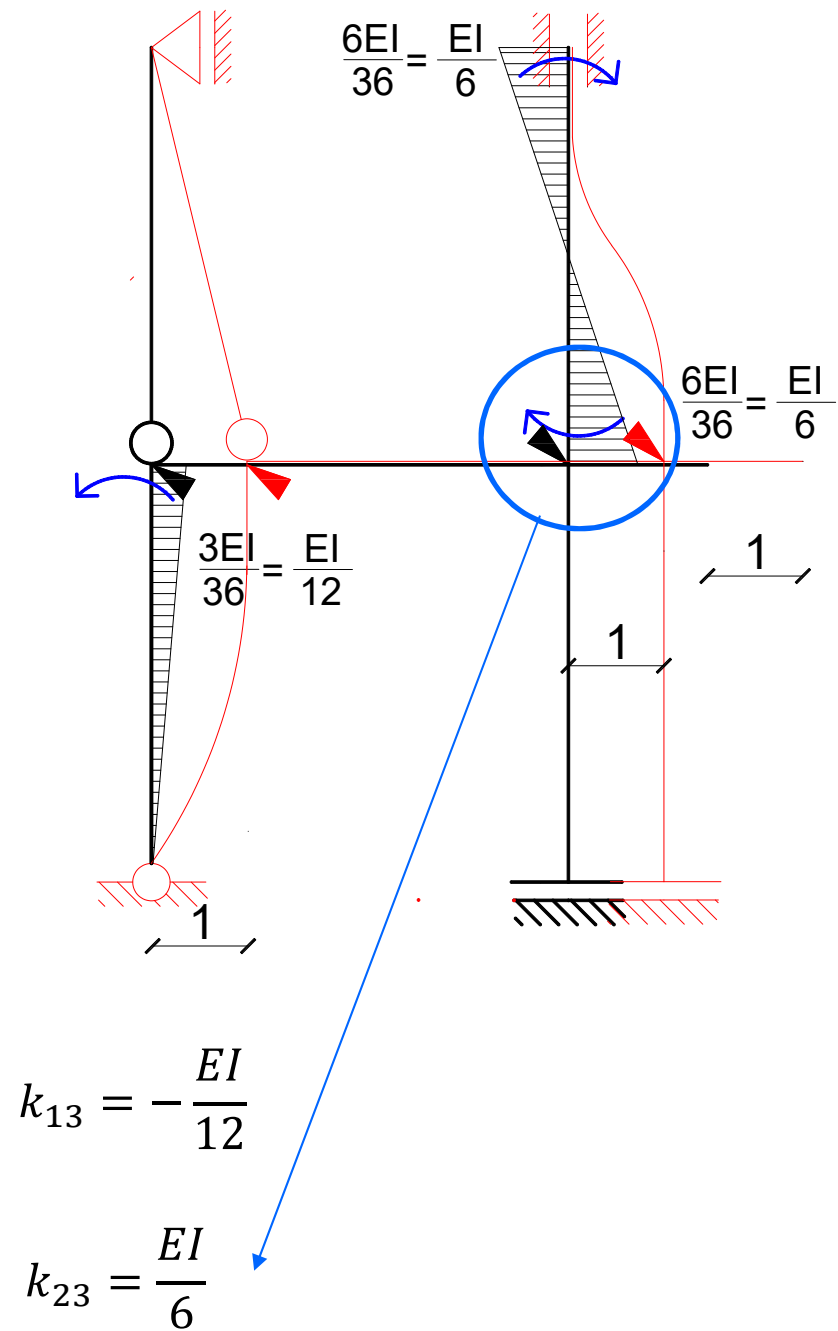

Stan $\Delta_3=1$

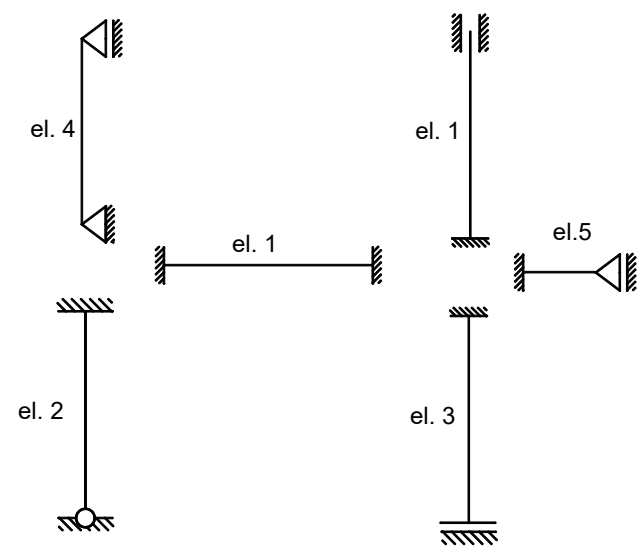

dr inž. Hanna Weber

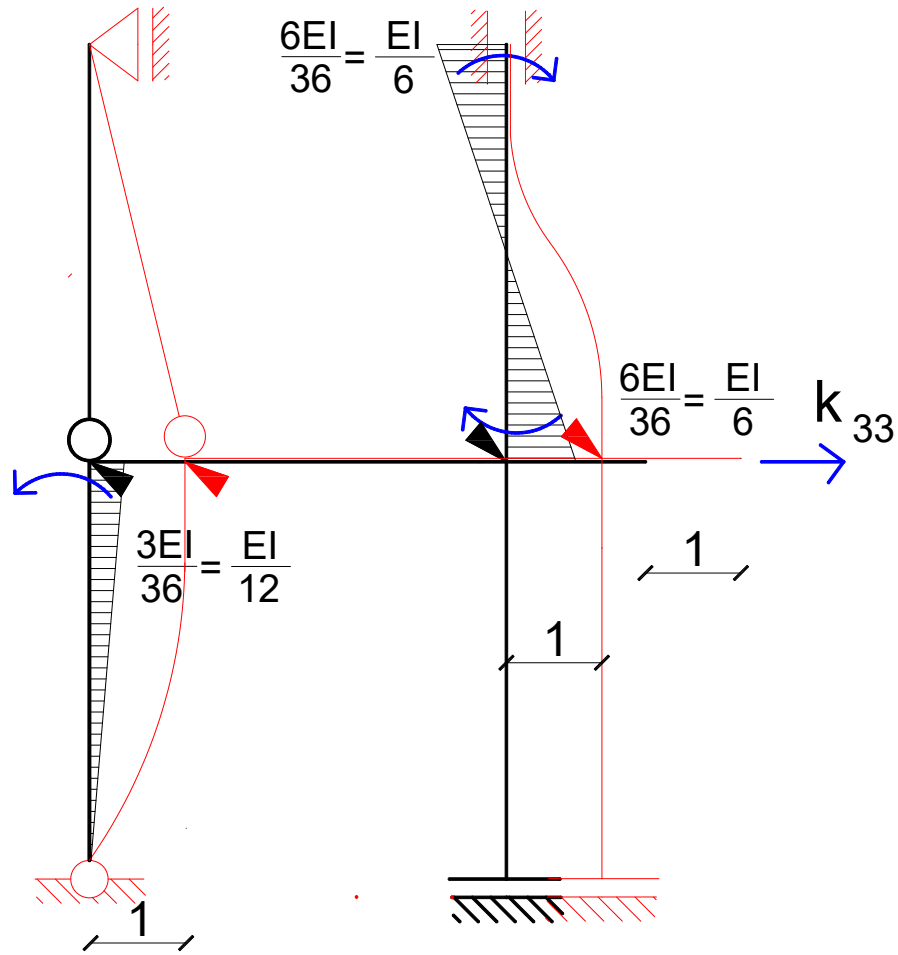

$$k_{13} = -\frac{EI}{12}$$

$$k_{23} = \frac{EI}{6}$$

Stan $\Delta_3=1$

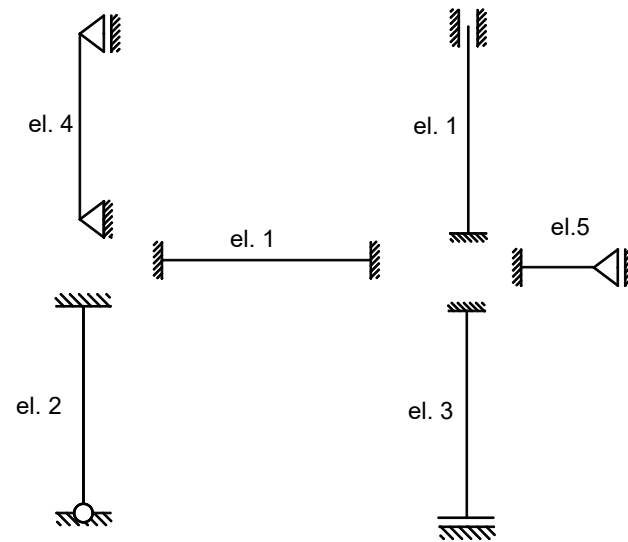

dr inž. Hanna Weber

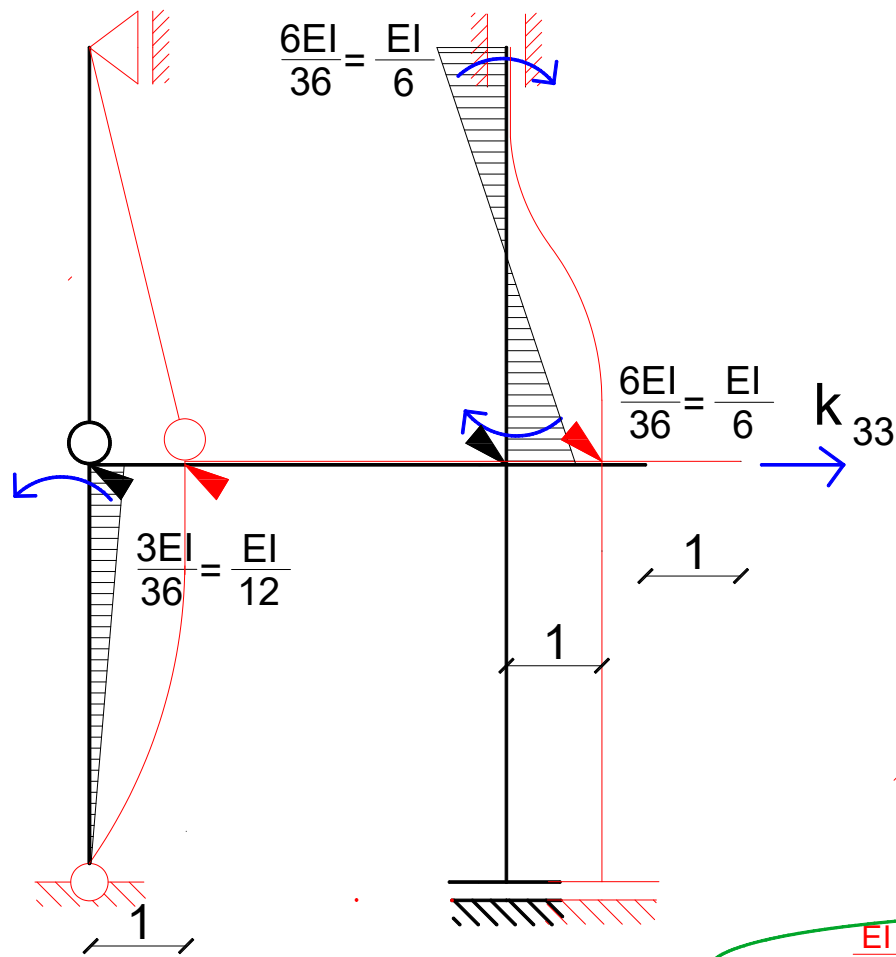

Stan $\Delta_3=1$

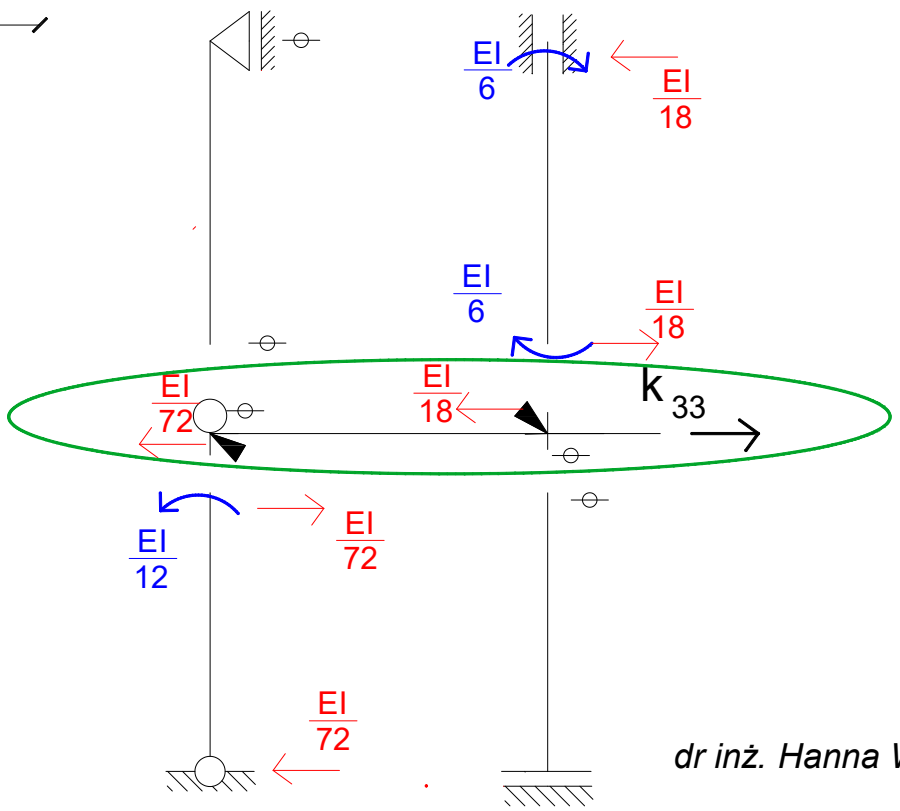

$$\sum R_x = -\frac{EI}{72} - \frac{EI}{18} + k_{33} = 0$$

$$k_{33} = \frac{5EI}{72}$$

dr inż. Hanna Weber

Obciążenie zewnętrzne

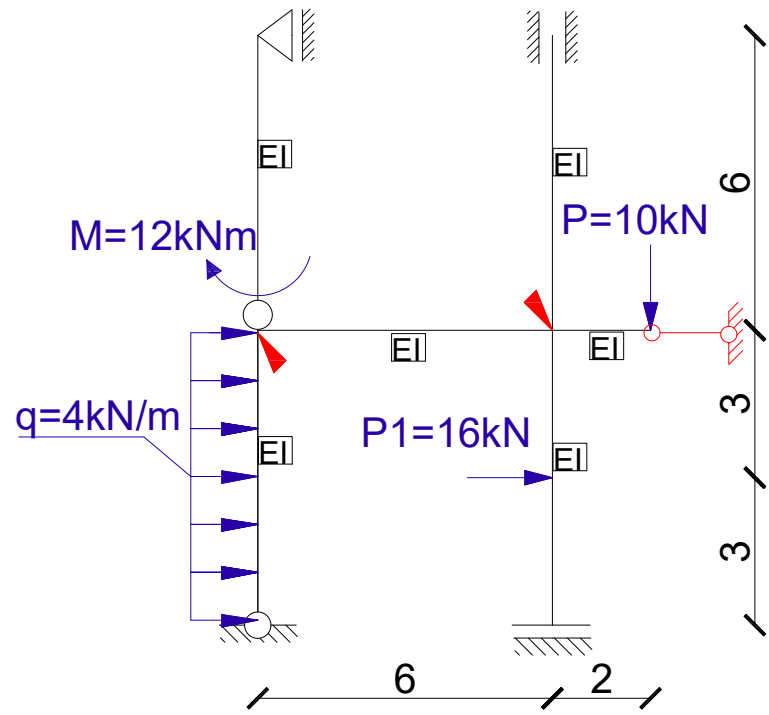

Obciążenie zewnętrzne

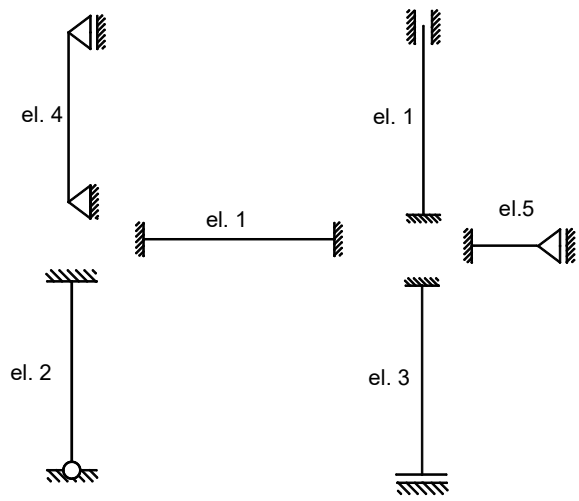
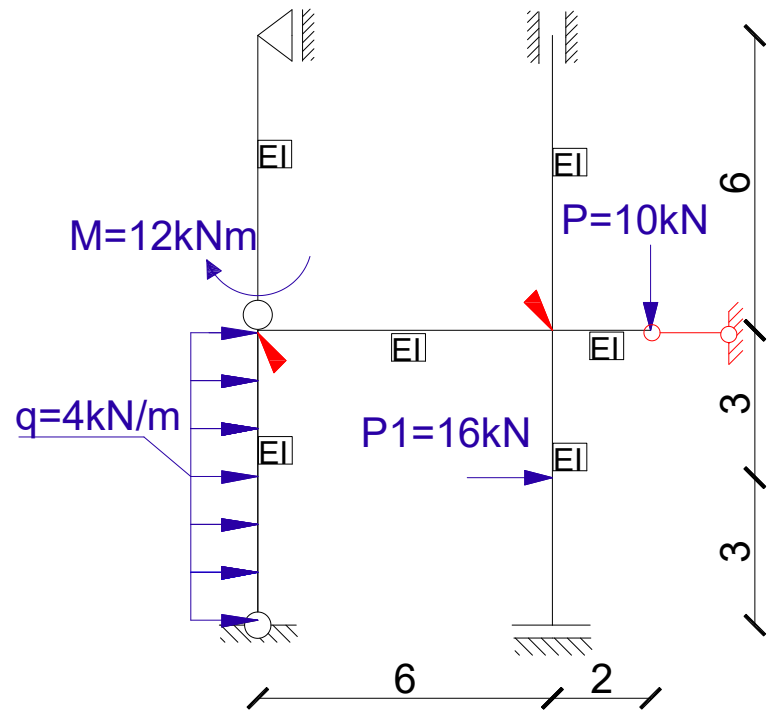

Obciążenie zewnętrzne

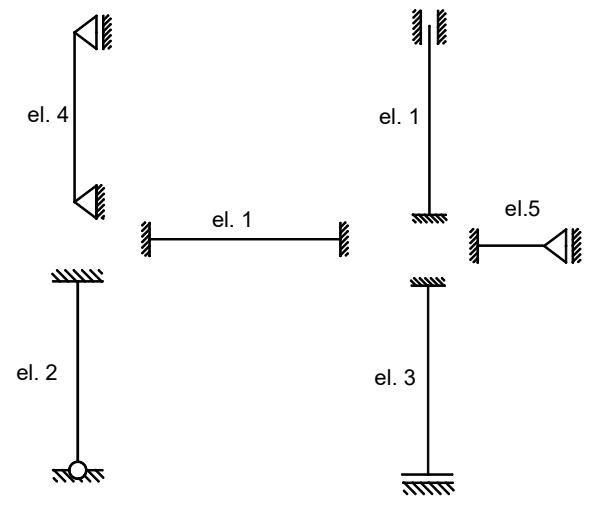
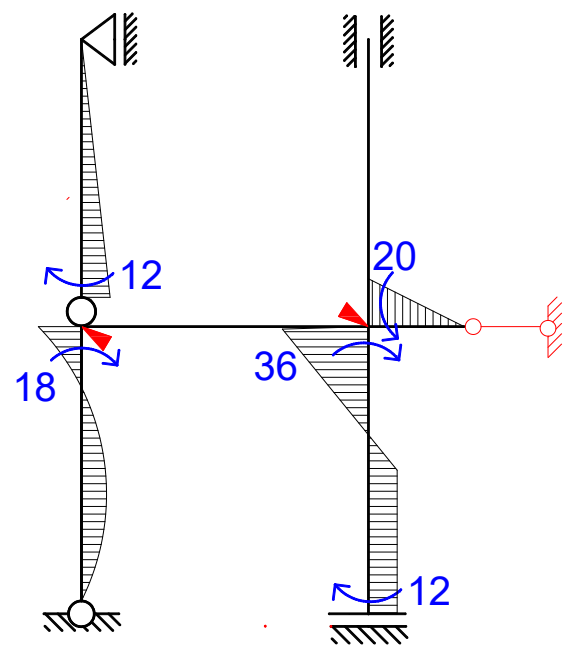
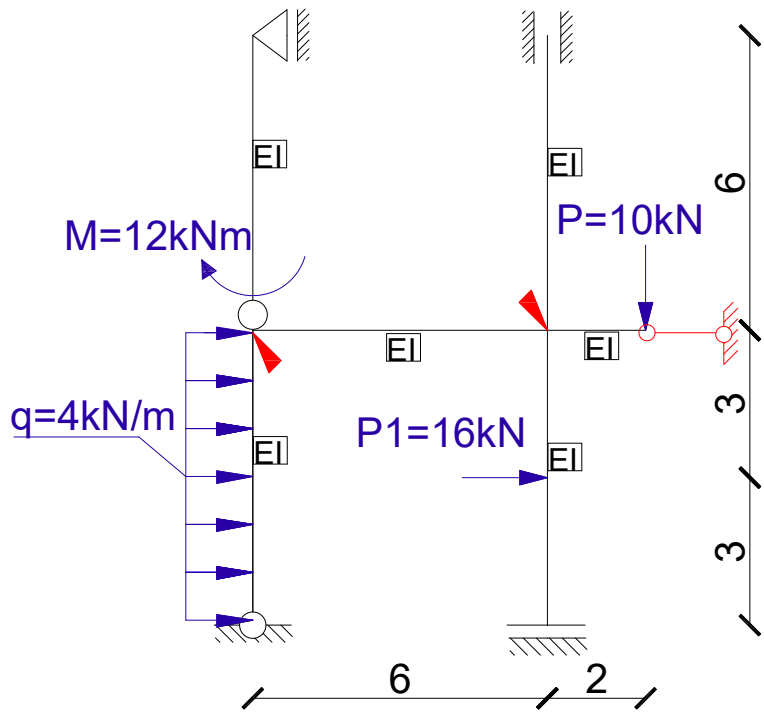

Obciążenie zewnętrzne

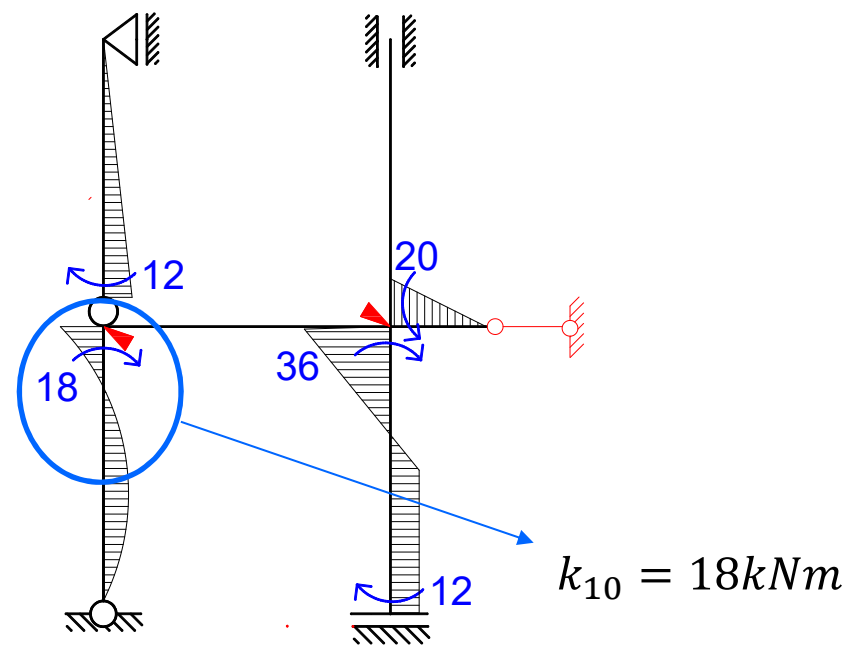
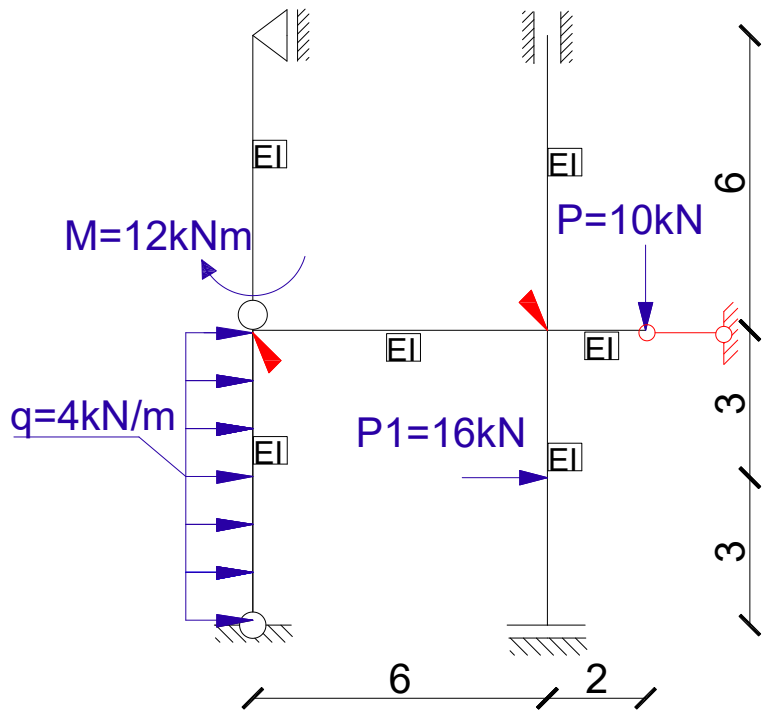

$k_{10} = 18 \text{ kNm}$

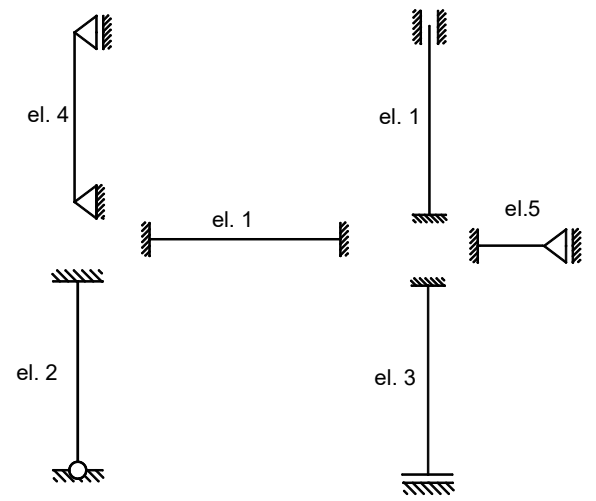

Obciążenie zewnętrzne

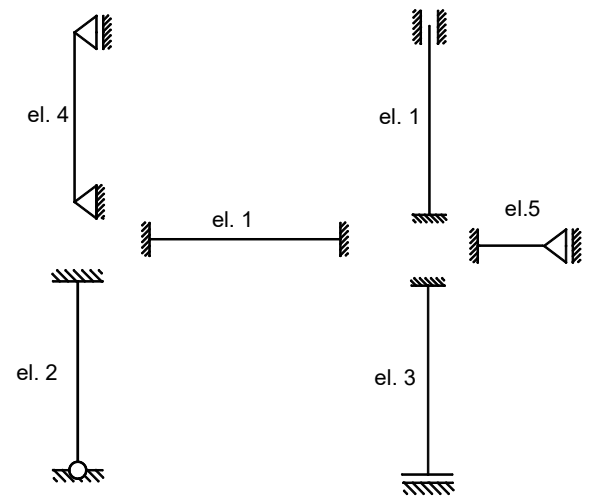
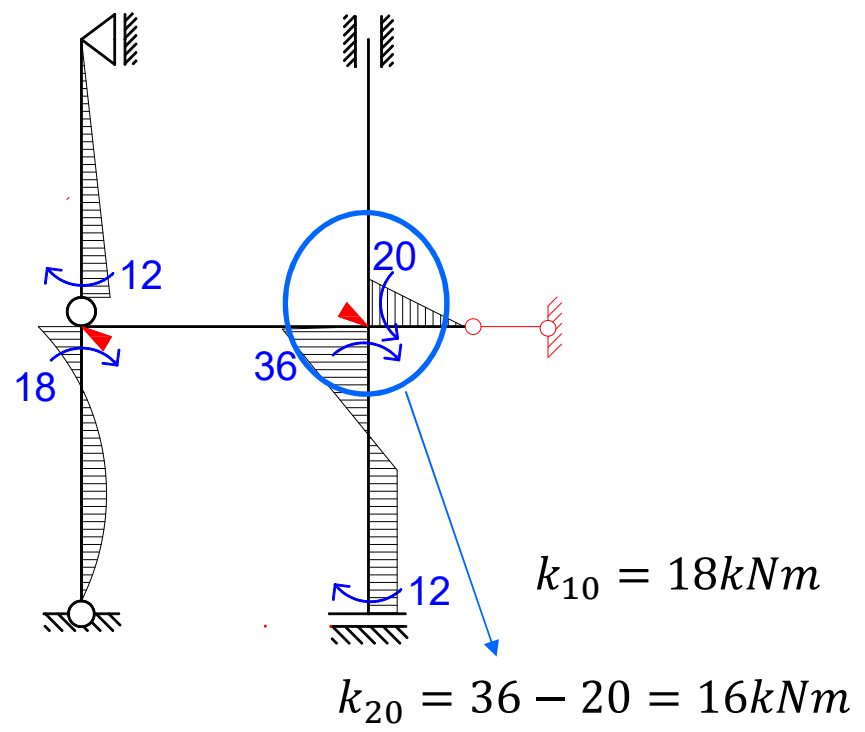
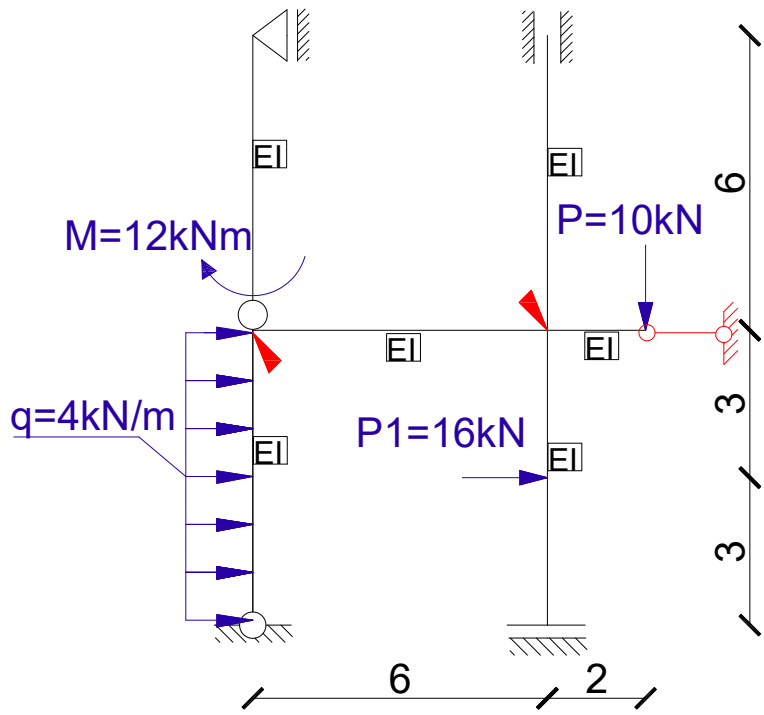

Obciążenie zewnętrzne

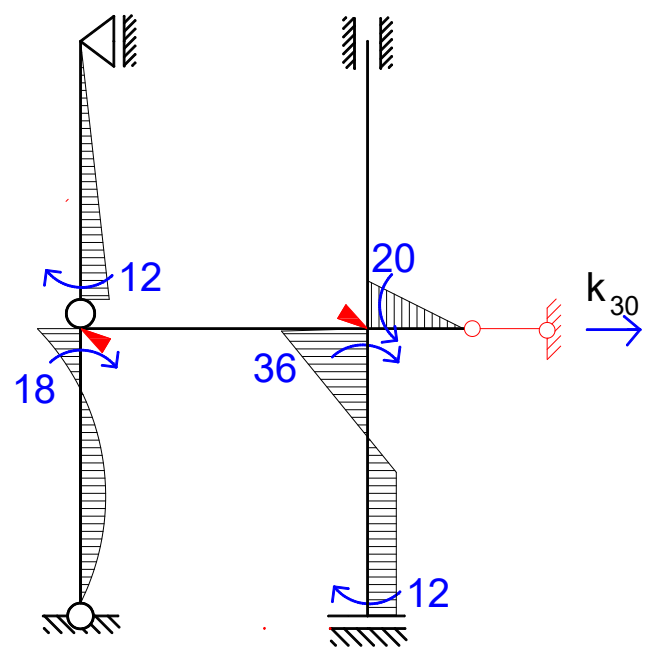
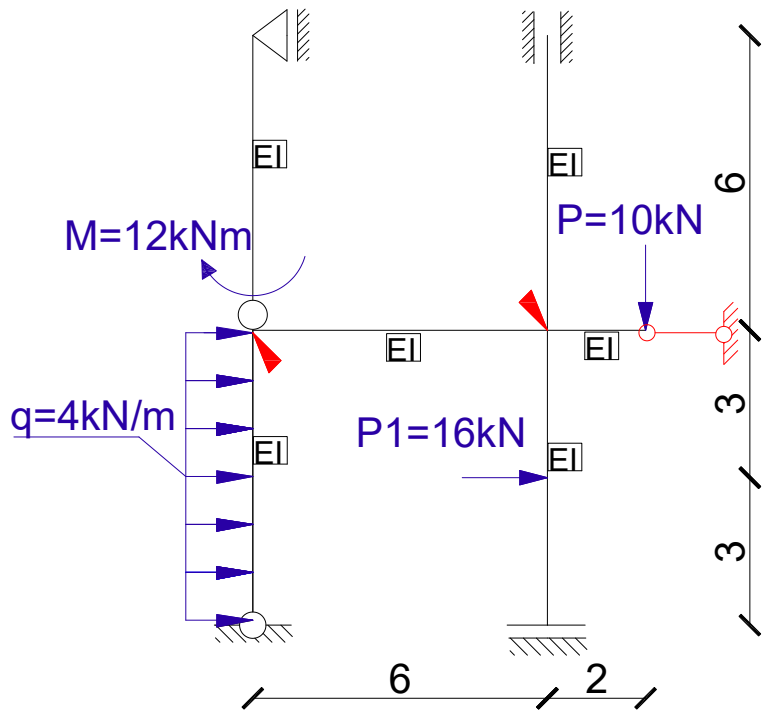

$$k_{10} = 18kNm$$

$$k_{20} = 36 - 20 = 16kNm$$

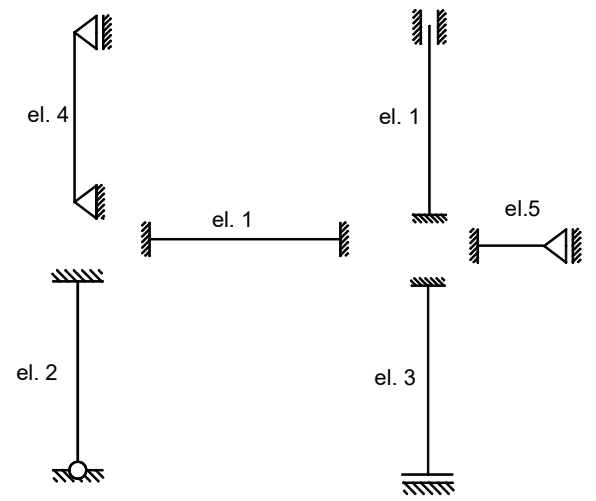

Obciążenie zewnętrzne

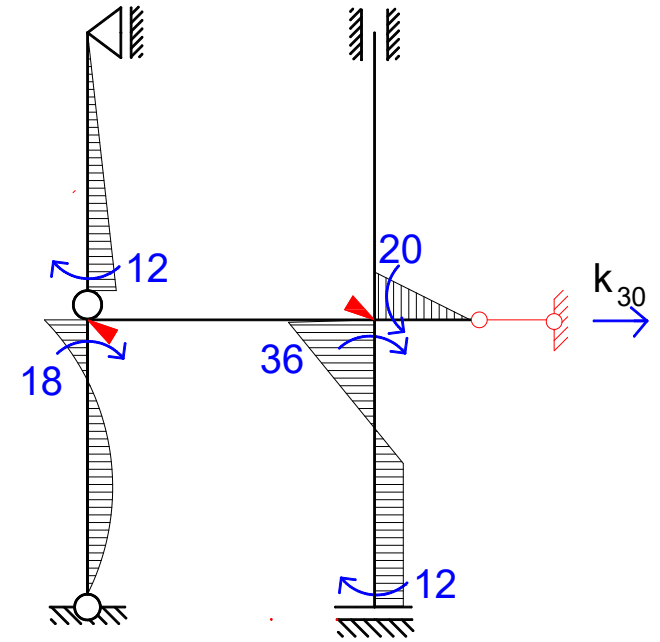
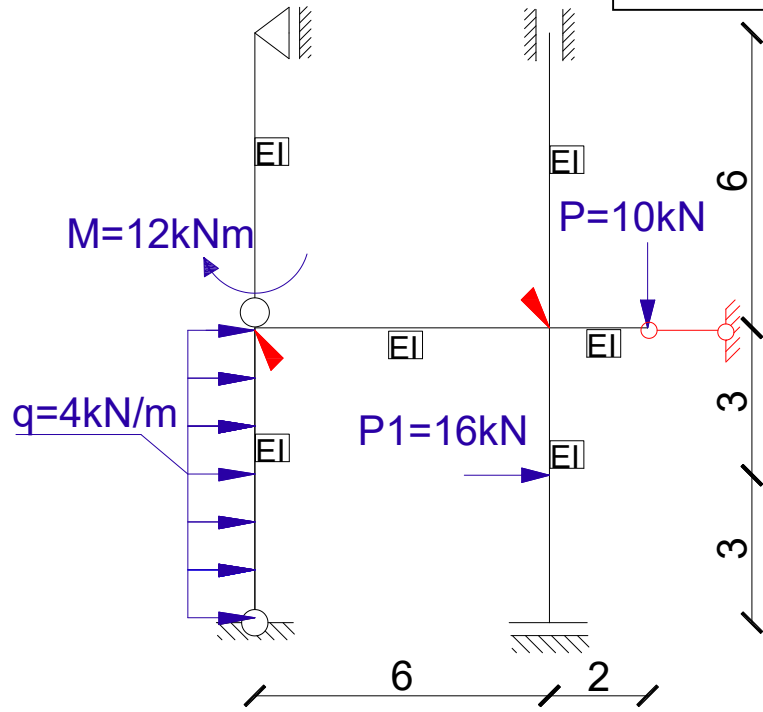

$$k_{10} = 18kNm$$

$$k_{20} = 36 - 20 = 16kNm$$

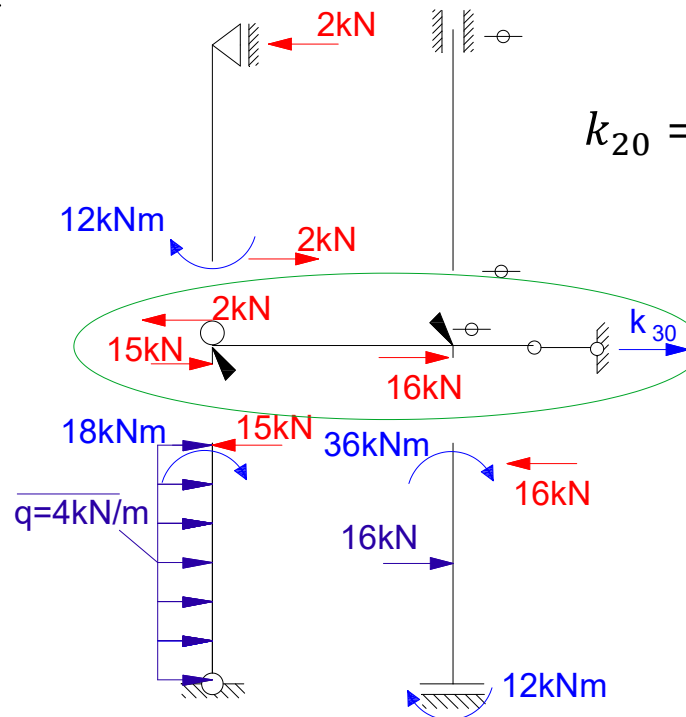
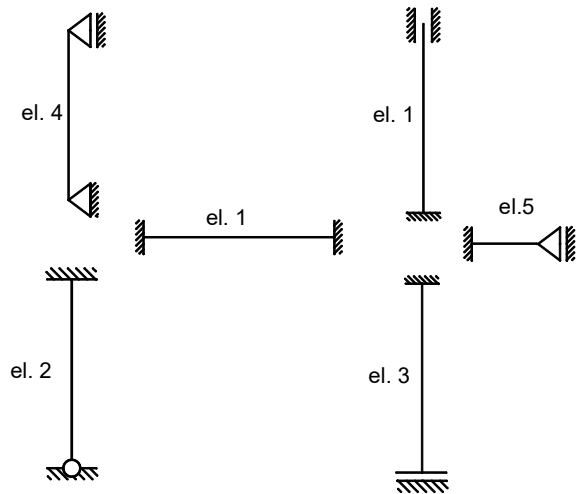

dr inż. Hanna Weber

Obciążenie zewnętrzne

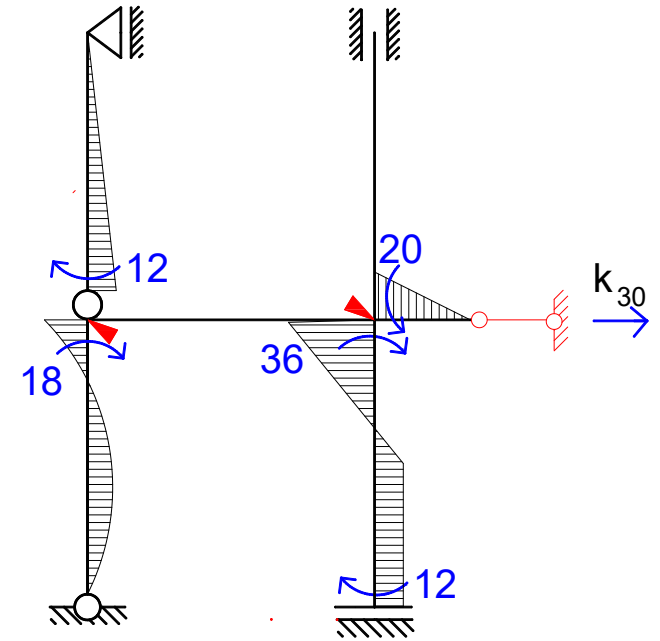
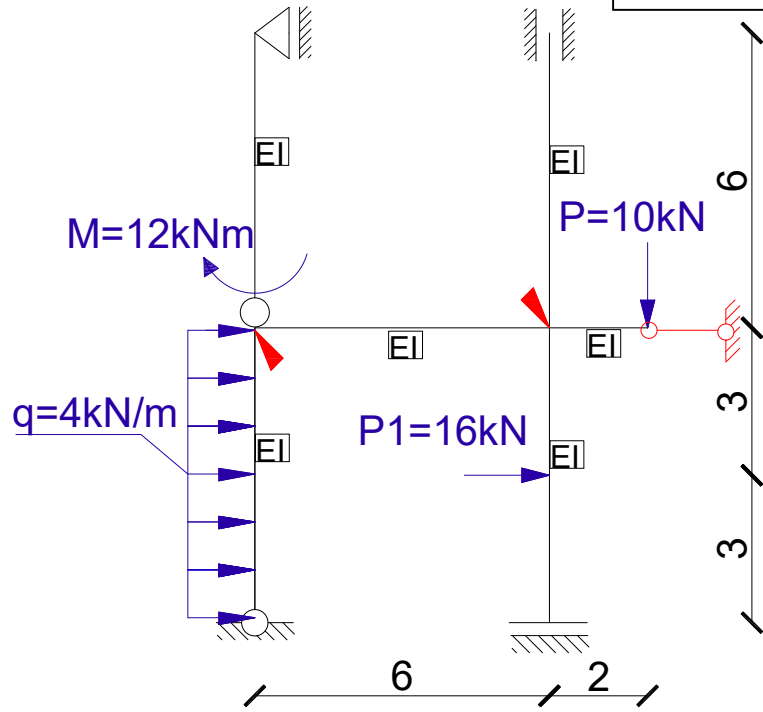

$$k_{10} = 18kNm$$

$$k_{20} = 36 - 20 = 16kNm$$

$$\sum R_x = -2 + 15 + 16 + k_{30} = 0$$

$$k_{30} = -29kN$$

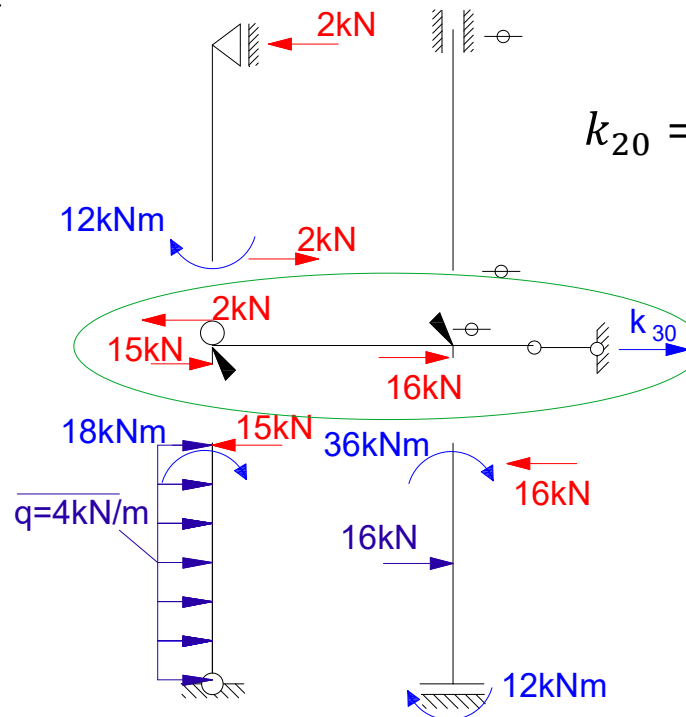

Układ równań metody przemieszczeń:

$$k_{11} \cdot \varphi_1 + k_{12} \cdot \varphi_2 + k_{13} \cdot \Delta_3 + k_{10} = 0$$

$$k_{21} \cdot \varphi_1 + k_{22} \cdot \varphi_2 + k_{23} \cdot \Delta_3 + k_{20} = 0$$

$$k_{31} \cdot \varphi_1 + k_{32} \cdot \varphi_2 + k_{33} \cdot \Delta_3 + k_{30} = 0$$

Podstawiając wyliczone wcześniej wartości otrzymujemy:

$$\frac{7EI}{6} \varphi_1 + \frac{EI}{3} \varphi_2 - \frac{EI}{12} \Delta_3 + 18 = 0$$

$$\frac{EI}{3} \varphi_1 + \frac{3EI}{2} \varphi_2 + \frac{EI}{6} \Delta_3 + 16 = 0$$

$$-\frac{EI}{12} \varphi_1 + \frac{EI}{6} \varphi_2 + \frac{5EI}{72} \Delta_3 - 29 = 0$$

Rozwiązanie układu równań:

$$\varphi_1 = \frac{72,15}{EI}$$

$$\varphi_2 = \frac{-112,8}{EI}$$

$$\Delta_3 = \frac{774,9}{EI}$$

Wyznaczenie momentów na końcach elementów:

$$\varphi_1 = \frac{72,15}{EI} \quad \varphi_2 = \frac{-112,8}{EI} \quad \Delta_3 = \frac{774,9}{EI}$$

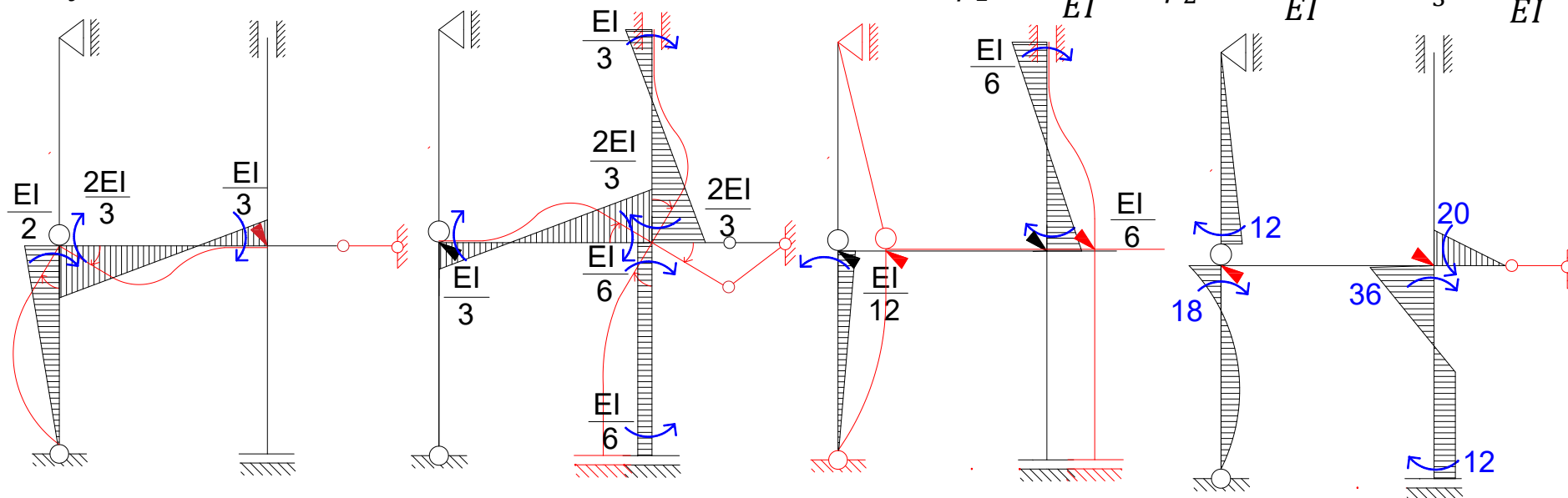

$$M_{Bd} = \frac{EI}{2} \cdot \frac{72,15}{EI} - \frac{EI}{12} \cdot \frac{774,9}{EI} + 18 = -10,5 \text{ kNm}$$

$$M_i = M^{\varphi_1=1} \cdot \varphi_1 + M^{\varphi_2=1} \cdot \varphi_2 + M^{\Delta_3=1} \cdot \Delta_3 + M^{obc.zewn.}$$

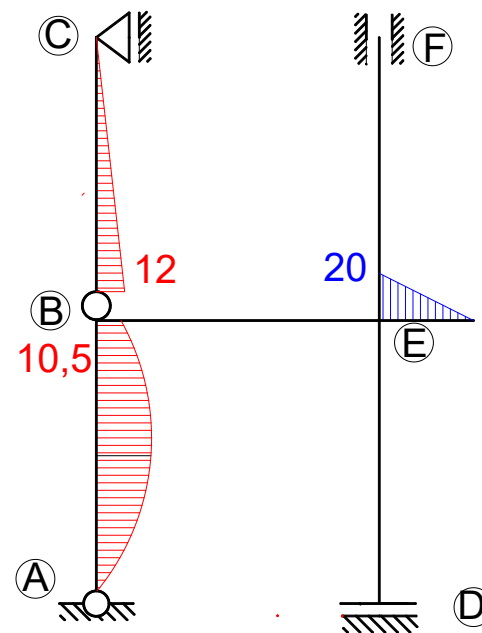

Wyznaczenie momentów na końcach elementów:

$$\varphi_1 = \frac{72,15}{EI} \quad \varphi_2 = \frac{-112,8}{EI} \quad \Delta_3 = \frac{774,9}{EI}$$

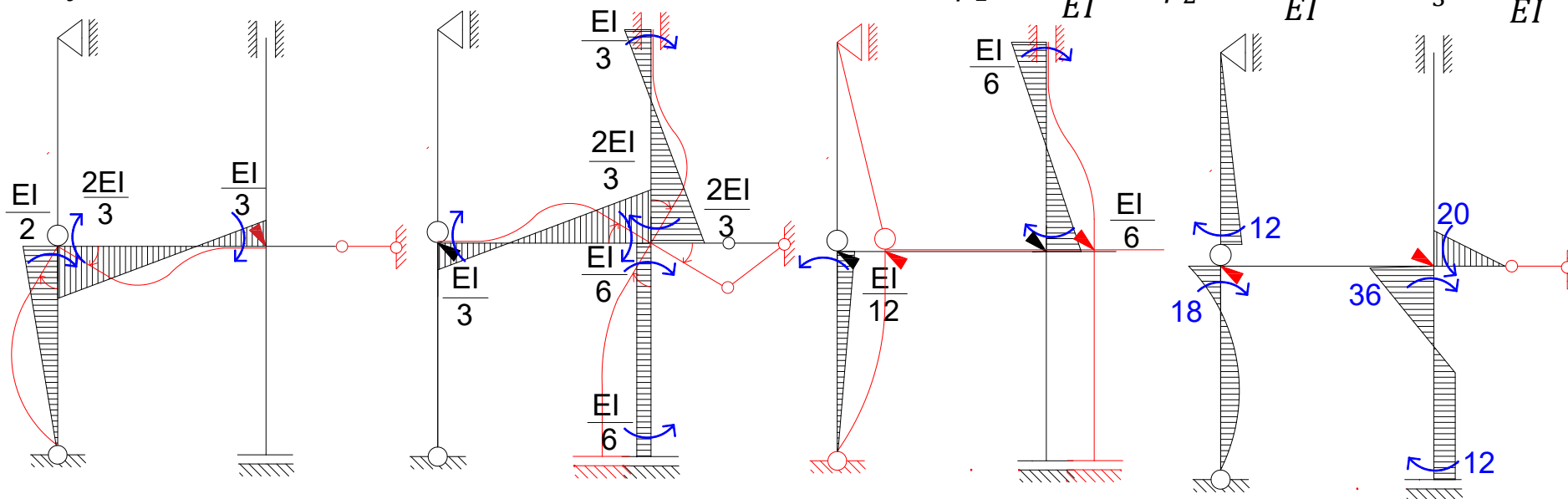

$$M_{Bd} = \frac{EI}{2} \cdot \frac{72,15}{EI} - \frac{EI}{12} \cdot \frac{774,9}{EI} + 18 = -10,5 \text{ kNm}$$

$$M_{Bp} = \frac{2EI}{3} \cdot \frac{72,15}{EI} + \frac{EI}{3} \cdot \frac{(-112,8)}{EI} = 10,5 \text{ kNm}$$

$$M_i = M^{\varphi_1=1} \cdot \varphi_1 + M^{\varphi_2=1} \cdot \varphi_2 + M^{\Delta_3=1} \cdot \Delta_3 + M^{obc.zewn.}$$

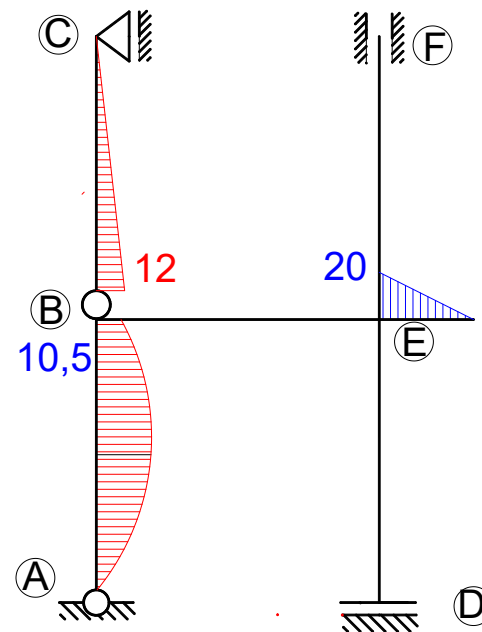

Wyznaczenie momentów na końcach elementów:

$$\varphi_1 = \frac{72,15}{EI} \quad \varphi_2 = \frac{-112,8}{EI} \quad \Delta_3 = \frac{774,9}{EI}$$

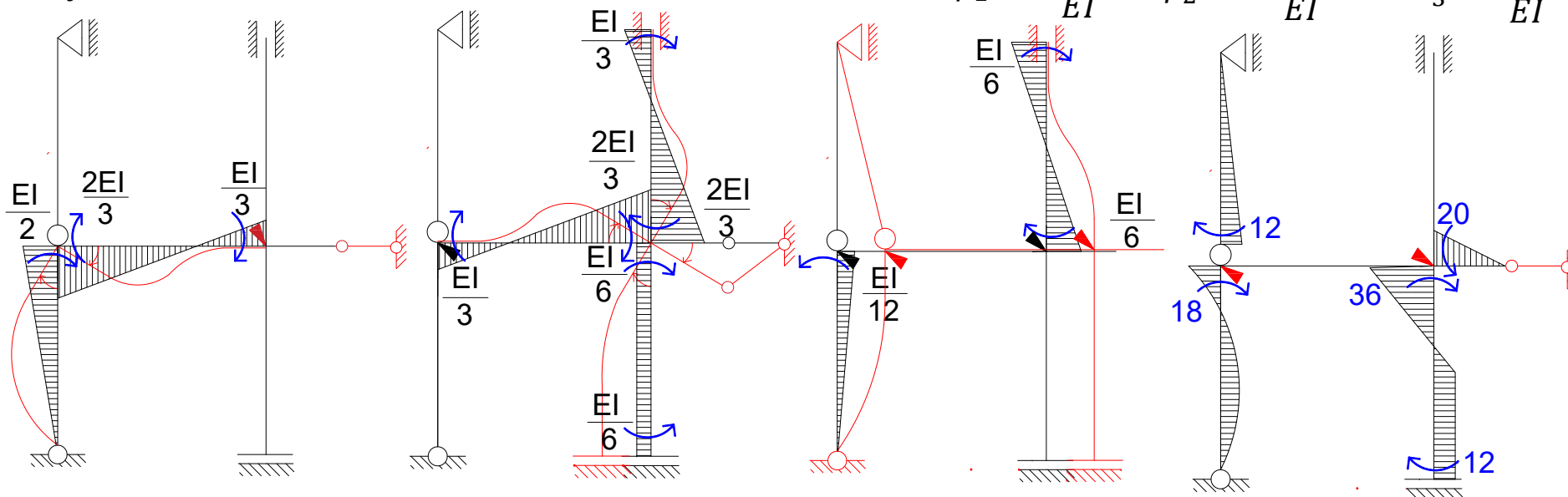

$$M_{Bd} = \frac{EI}{2} \cdot \frac{72,15}{EI} - \frac{EI}{12} \cdot \frac{774,9}{EI} + 18 = -10,5 \text{ kNm}$$

$$M_{Bp} = \frac{2EI}{3} \cdot \frac{72,15}{EI} + \frac{EI}{3} \cdot \frac{(-112,8)}{EI} = 10,5 \text{ kNm}$$

$$M_{EL} = \frac{EI}{3} \cdot \frac{72,15}{EI} + \frac{2EI}{3} \cdot \frac{(-112,8)}{EI} = -51,15 \text{ kNm}$$

$$M_i = M^{\varphi_1=1} \cdot \varphi_1 + M^{\varphi_2=1} \cdot \varphi_2 + M^{\Delta_3=1} \cdot \Delta_3 + M^{obc.zewn.}$$

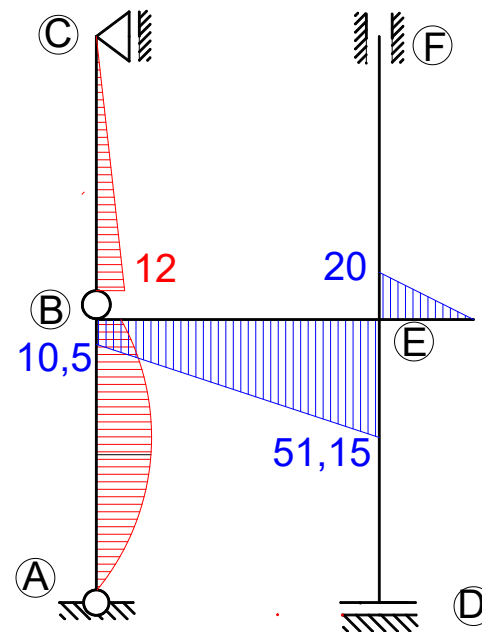

Wyznaczenie momentów na końcach elementów:

$$\varphi_1 = \frac{72,15}{EI} \quad \varphi_2 = \frac{-112,8}{EI} \quad \Delta_3 = \frac{774,9}{EI}$$

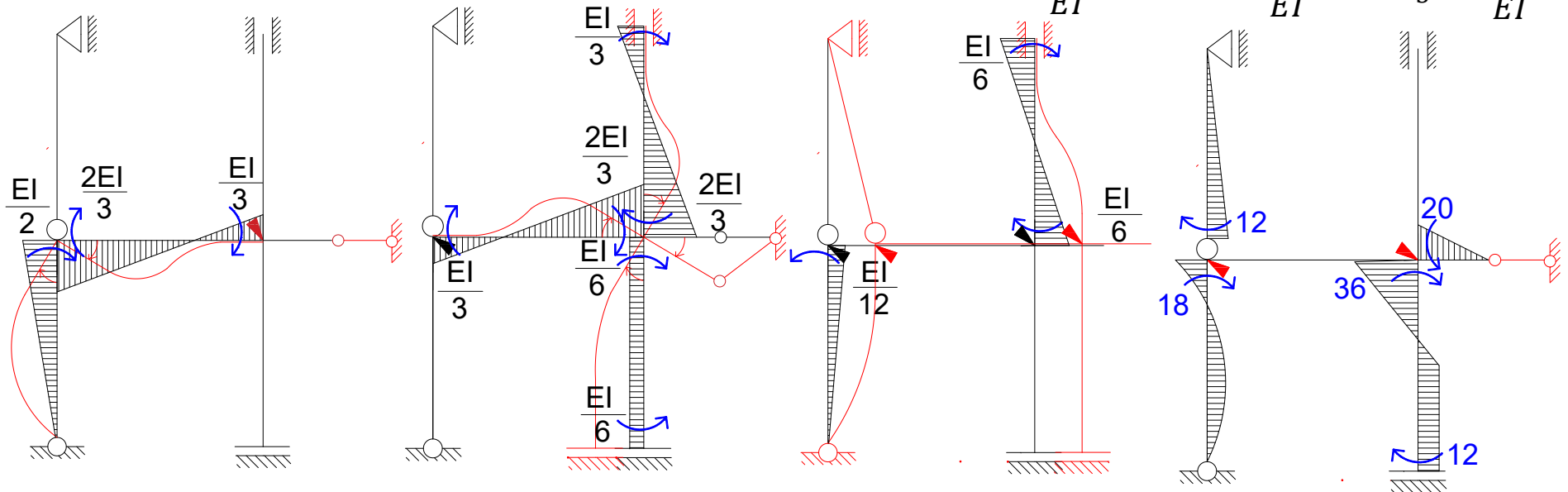

$$M_{Bd} = \frac{EI}{2} \cdot \frac{72,15}{EI} - \frac{EI}{12} \cdot \frac{774,9}{EI} + 18 = -10,5 \text{ kNm}$$

$$M_{Bp} = \frac{2EI}{3} \cdot \frac{72,15}{EI} + \frac{EI}{3} \cdot \frac{(-112,8)}{EI} = 10,5 \text{ kNm}$$

$$M_{EL} = \frac{EI}{3} \cdot \frac{72,15}{EI} + \frac{2EI}{3} \cdot \frac{(-112,8)}{EI} = -51,15 \text{ kNm}$$

$$M_D = -\frac{EI}{6} \cdot \frac{(-112,8)}{EI} + 12 = 30,8 \text{ kNm}$$

$$M_{Ed} = \frac{EI}{6} \cdot \frac{(-112,8)}{EI} + 36 = 17,2 \text{ kNm}$$

$$M_i = M^{\varphi_1=1} \cdot \varphi_1 + M^{\varphi_2=1} \cdot \varphi_2 + M^{\Delta_3=1} \cdot \Delta_3 + M^{obc.zewn.}$$

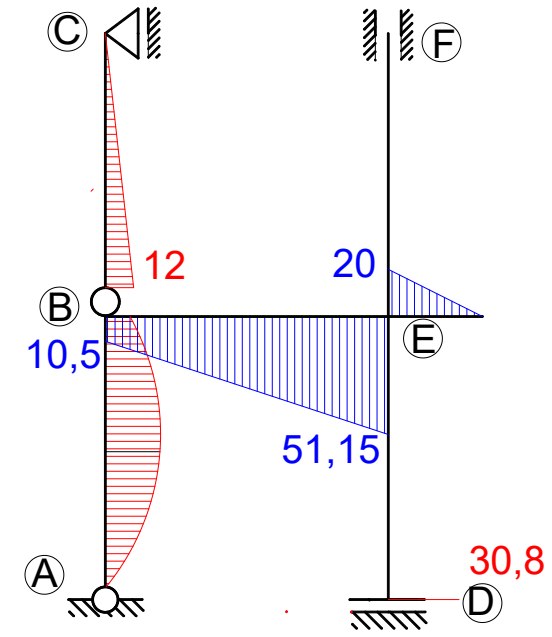

Wyznaczenie momentów na końcach elementów:

$$\varphi_1 = \frac{72,15}{EI} \quad \varphi_2 = \frac{-112,8}{EI} \quad \Delta_3 = \frac{774,9}{EI}$$

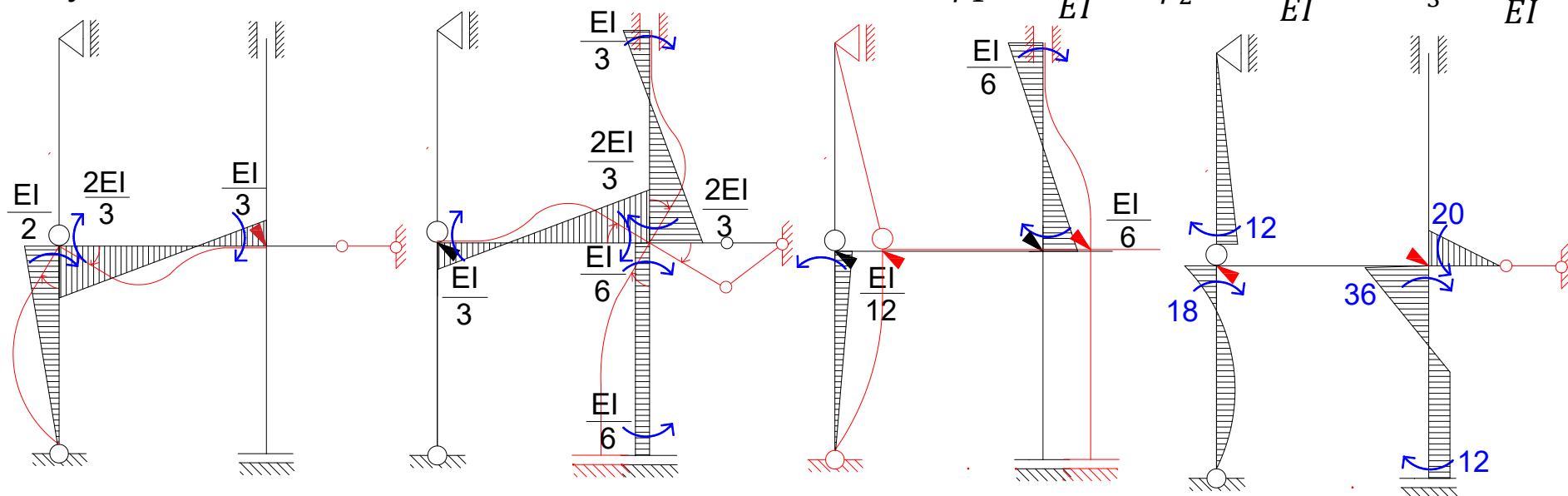

$$M_{Bd} = \frac{EI}{2} \cdot \frac{72,15}{EI} - \frac{EI}{12} \cdot \frac{774,9}{EI} + 18 = -10,5 \text{ kNm}$$

$$M_{Bp} = \frac{2EI}{3} \cdot \frac{72,15}{EI} + \frac{EI}{3} \cdot \frac{(-112,8)}{EI} = 10,5 \text{ kNm}$$

$$M_{EL} = \frac{EI}{3} \cdot \frac{72,15}{EI} + \frac{2EI}{3} \cdot \frac{(-112,8)}{EI} = -51,15 \text{ kNm}$$

$$M_D = -\frac{EI}{6} \cdot \frac{(-112,8)}{EI} + 12 = 30,8 \text{ kNm}$$

$$M_{Ed} = \frac{EI}{6} \cdot \frac{(-112,8)}{EI} + 36 = 17,2 \text{ kNm}$$

$$M_i = M^{\varphi_1=1} \cdot \varphi_1 + M^{\varphi_2=1} \cdot \varphi_2 + M^{\Delta_3=1} \cdot \Delta_3 + M^{obc.zewn.}$$

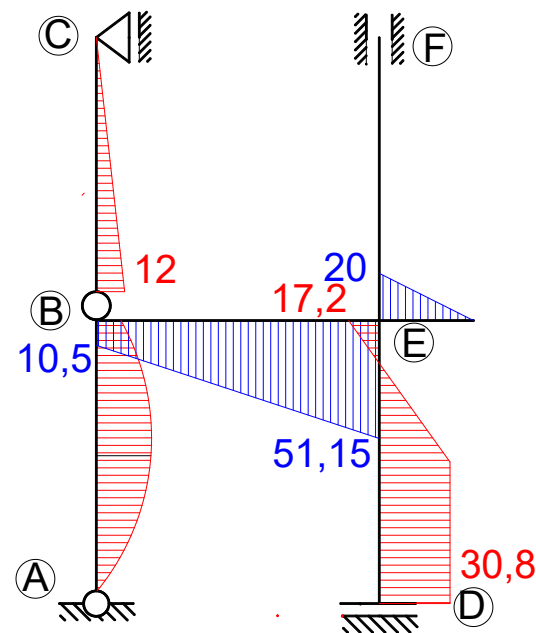

Wyznaczenie momentów na końcach elementów:

$$\varphi_1 = \frac{72,15}{EI} \quad \varphi_2 = \frac{-112,8}{EI} \quad \Delta_3 = \frac{774,9}{EI}$$

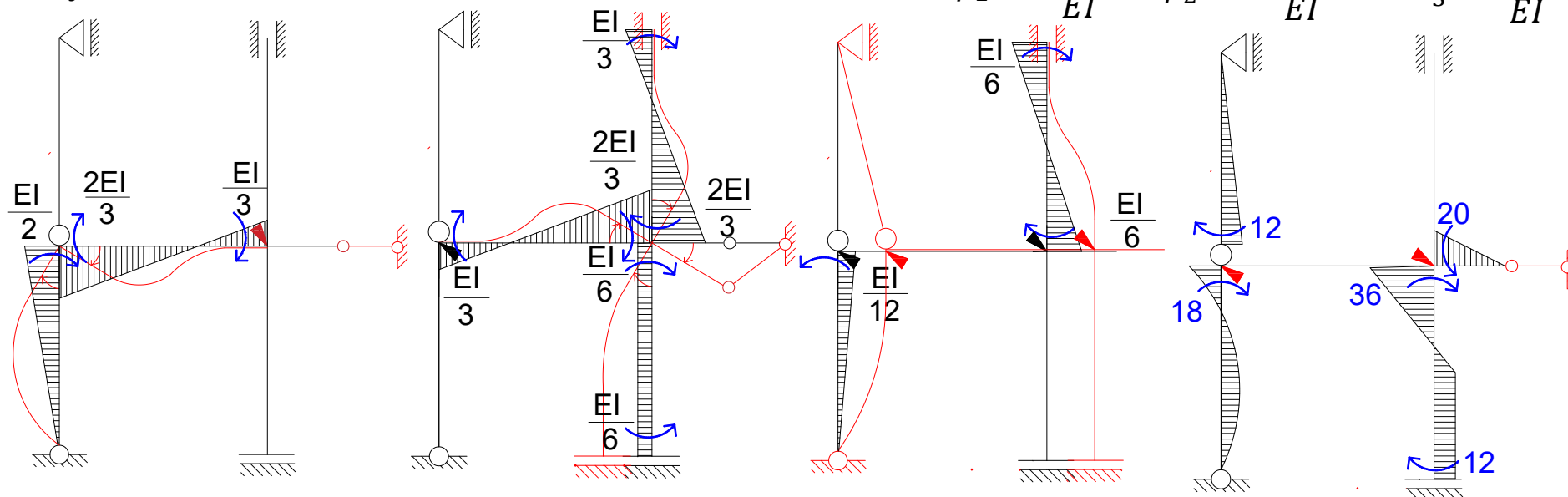

$$M_{Bd} = \frac{EI}{2} \cdot \frac{72,15}{EI} - \frac{EI}{12} \cdot \frac{774,9}{EI} + 18 = -10,5 \text{ kNm}$$

$$M_{Bp} = \frac{2EI}{3} \cdot \frac{72,15}{EI} + \frac{EI}{3} \cdot \frac{(-112,8)}{EI} = 10,5 \text{ kNm}$$

$$M_{EL} = \frac{EI}{3} \cdot \frac{72,15}{EI} + \frac{2EI}{3} \cdot \frac{(-112,8)}{EI} = -51,15 \text{ kNm}$$

$$M_D = -\frac{EI}{6} \cdot \frac{(-112,8)}{EI} + 12 = 30,8 \text{ kNm}$$

$$M_{Ed} = \frac{EI}{6} \cdot \frac{(-112,8)}{EI} + 36 = 17,2 \text{ kNm}$$

$$M_{Eg} = \frac{2EI}{3} \cdot \frac{(-112,8)}{EI} + \frac{EI}{6} \cdot \frac{774,9}{EI} = 53,95 \text{ kNm}$$

$$M_i = M^{\varphi_1=1} \cdot \varphi_1 + M^{\varphi_2=1} \cdot \varphi_2 + M^{\Delta_3=1} \cdot \Delta_3 + M^{obc.zewn.}$$

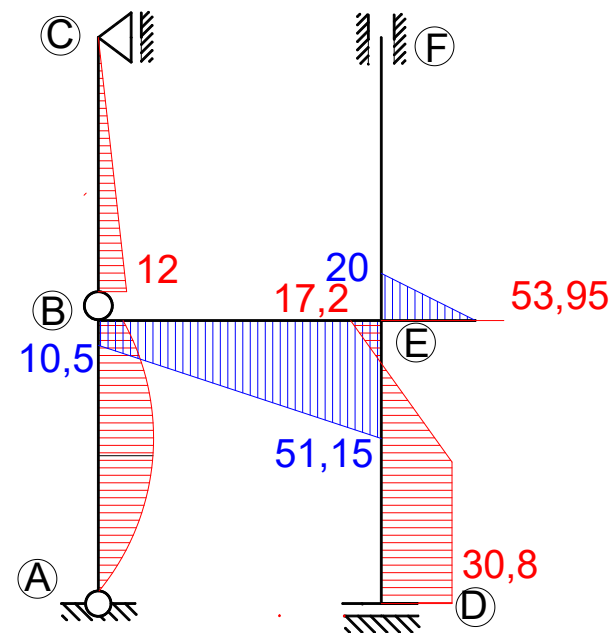

Wyznaczenie momentów na końcach elementów:

$$\varphi_1 = \frac{72,15}{EI} \quad \varphi_2 = \frac{-112,8}{EI} \quad \Delta_3 = \frac{774,9}{EI}$$

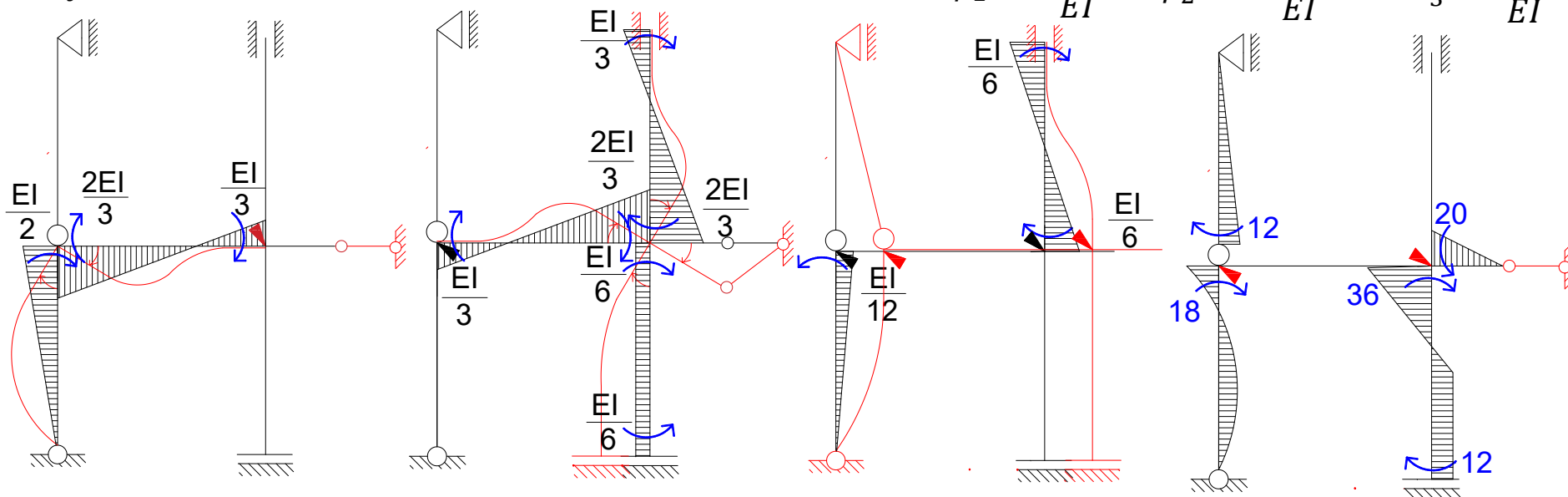

$$M_{Bd} = \frac{EI}{2} \cdot \frac{72,15}{EI} - \frac{EI}{12} \cdot \frac{774,9}{EI} + 18 = -10,5 \text{ kNm}$$

$$M_{Bp} = \frac{2EI}{3} \cdot \frac{72,15}{EI} + \frac{EI}{3} \cdot \frac{(-112,8)}{EI} = 10,5 \text{ kNm}$$

$$M_{EL} = \frac{EI}{3} \cdot \frac{72,15}{EI} + \frac{2EI}{3} \cdot \frac{(-112,8)}{EI} = -51,15 \text{ kNm}$$

$$M_D = -\frac{EI}{6} \cdot \frac{(-112,8)}{EI} + 12 = 30,8 \text{ kNm}$$

$$M_{Ed} = \frac{EI}{6} \cdot \frac{(-112,8)}{EI} + 36 = 17,2 \text{ kNm}$$

$$M_{Eg} = \frac{2EI}{3} \cdot \frac{(-112,8)}{EI} + \frac{EI}{6} \cdot \frac{774,9}{EI} = 53,95 \text{ kNm}$$

$$M_F = \frac{EI}{3} \cdot \frac{(-112,8)}{EI} + \frac{EI}{6} \cdot \frac{774,9}{EI} = 91,55 \text{ kNm}$$

$$M_i = M^{\varphi_1=1} \cdot \varphi_1 + M^{\varphi_2=1} \cdot \varphi_2 + M^{\Delta_3=1} \cdot \Delta_3 + M^{obc.zewn.}$$

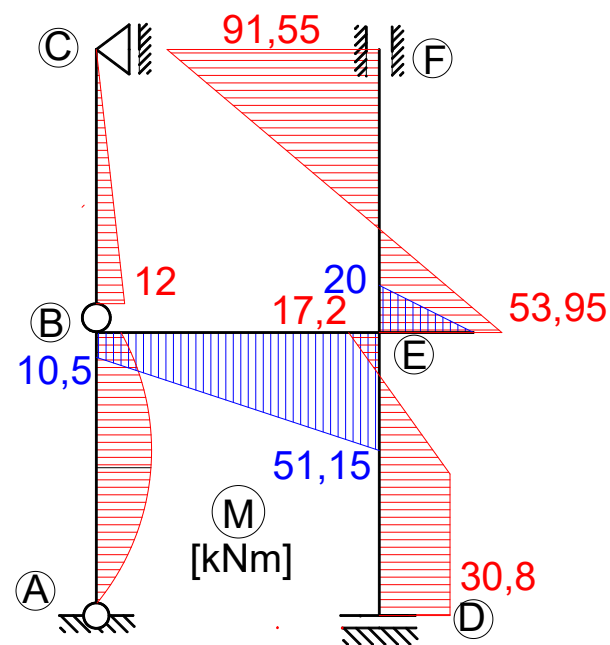

Wyznaczenie sił tnących i normalnych na podstawie wykresu M:

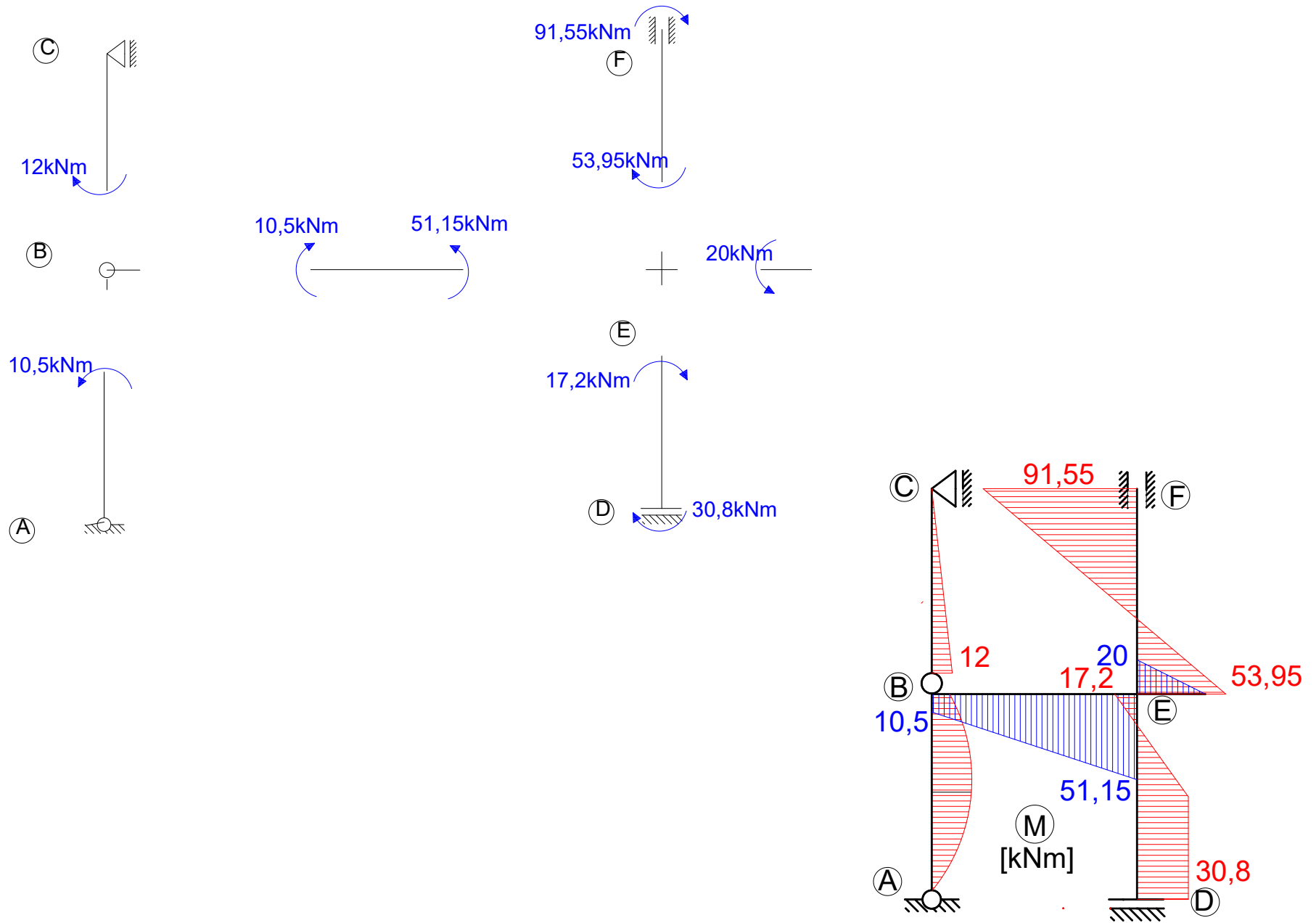

Wyznaczenie sił tnących i normalnych na podstawie wykresu M:

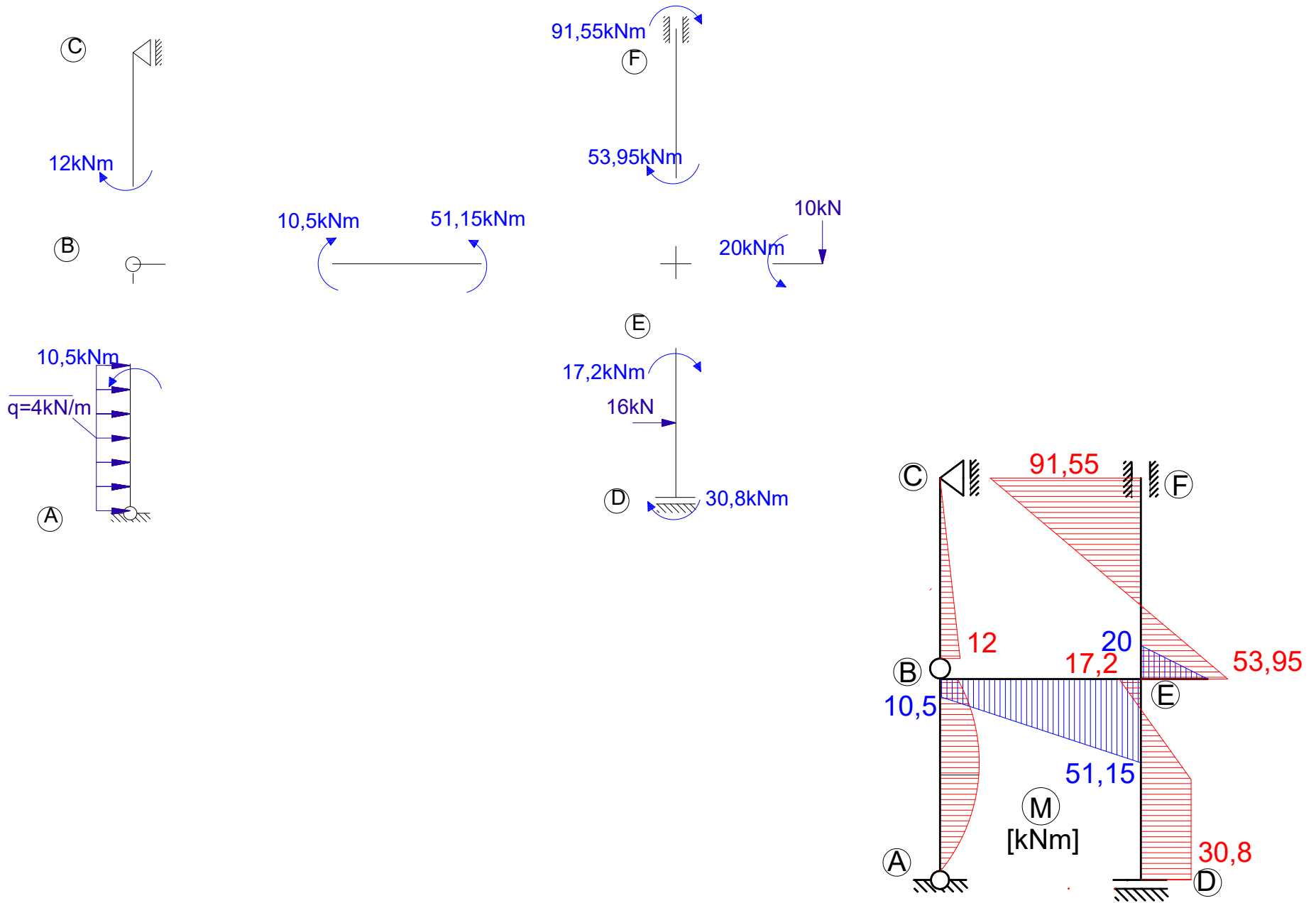

Wyznaczenie sił tnących i normalnych na podstawie wykresu M:

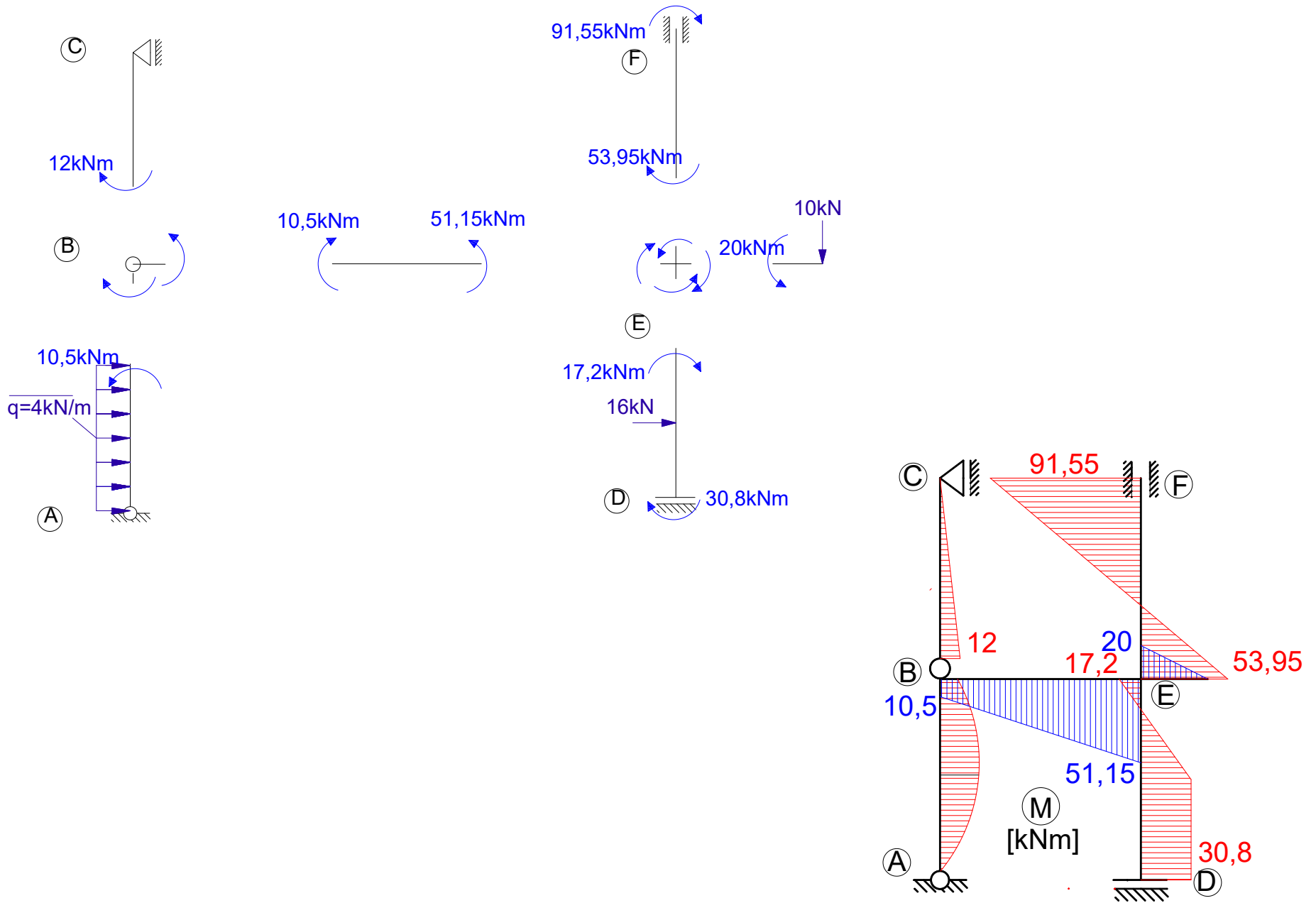

Wyznaczenie sił tnących i normalnych na podstawie wykresu M:

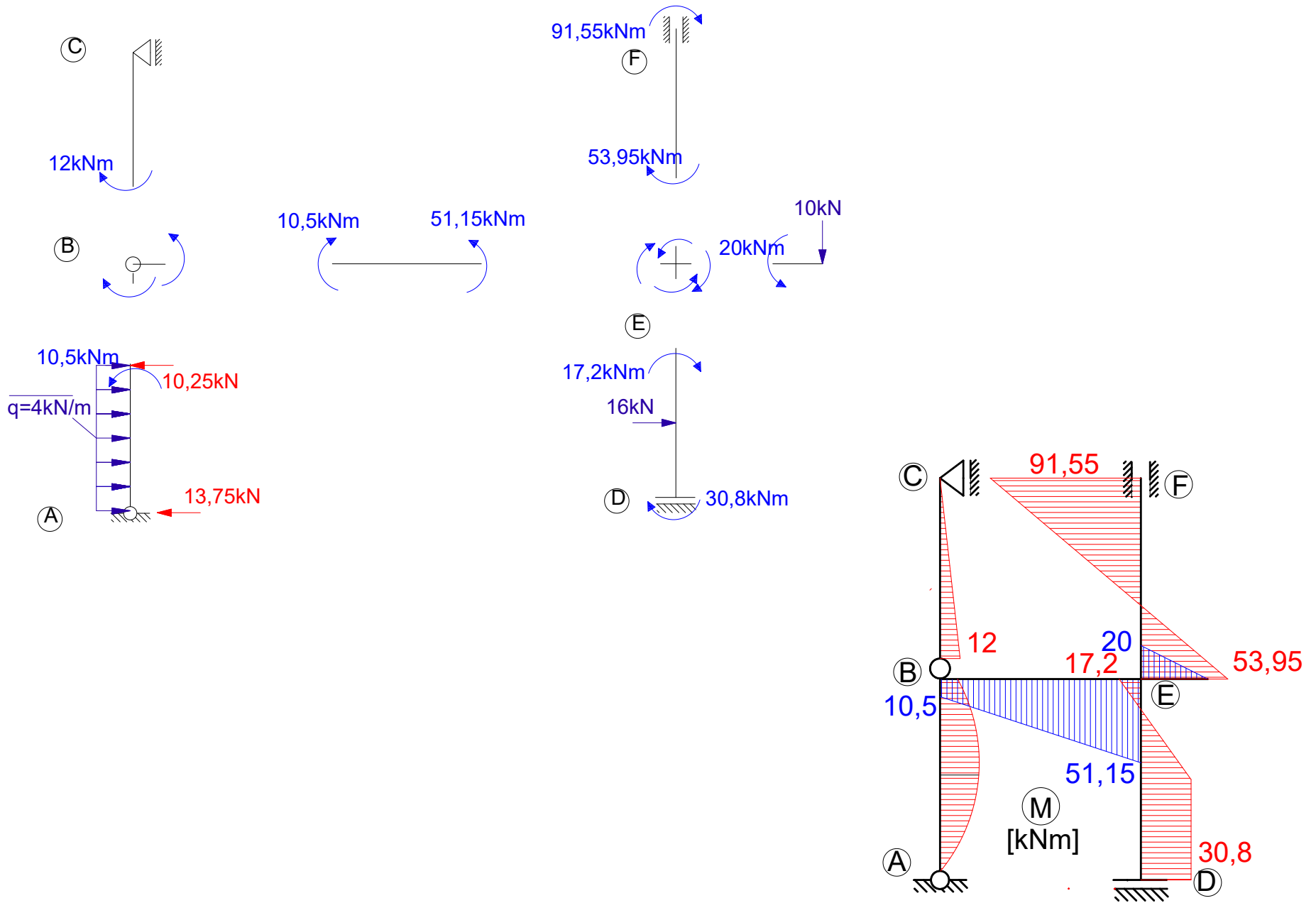

Wyznaczenie sił tnących i normalnych na podstawie wykresu M:

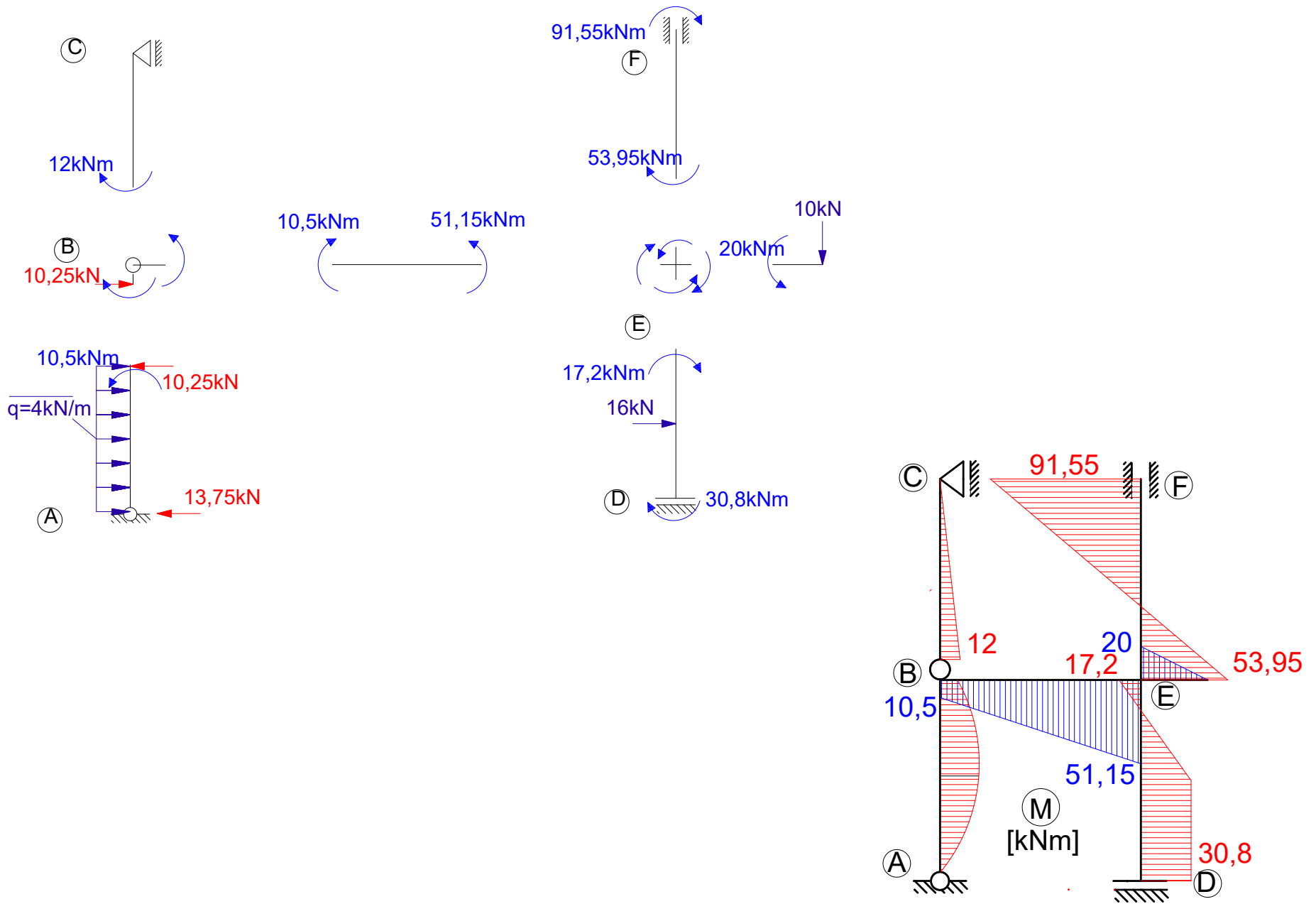

Wyznaczenie sił tnących i normalnych na podstawie wykresu M:

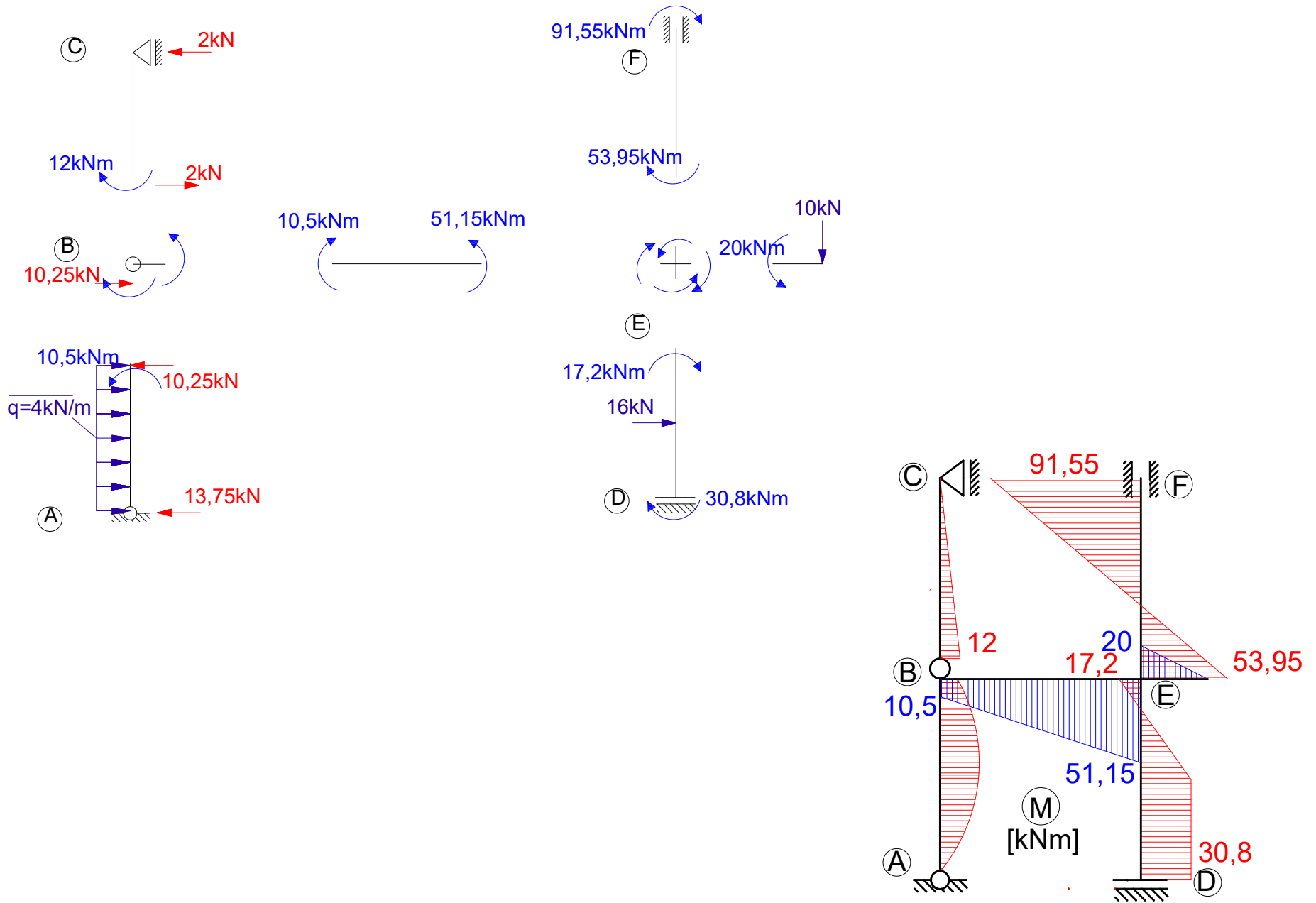

Wyznaczenie sił tnących i normalnych na podstawie wykresu M:

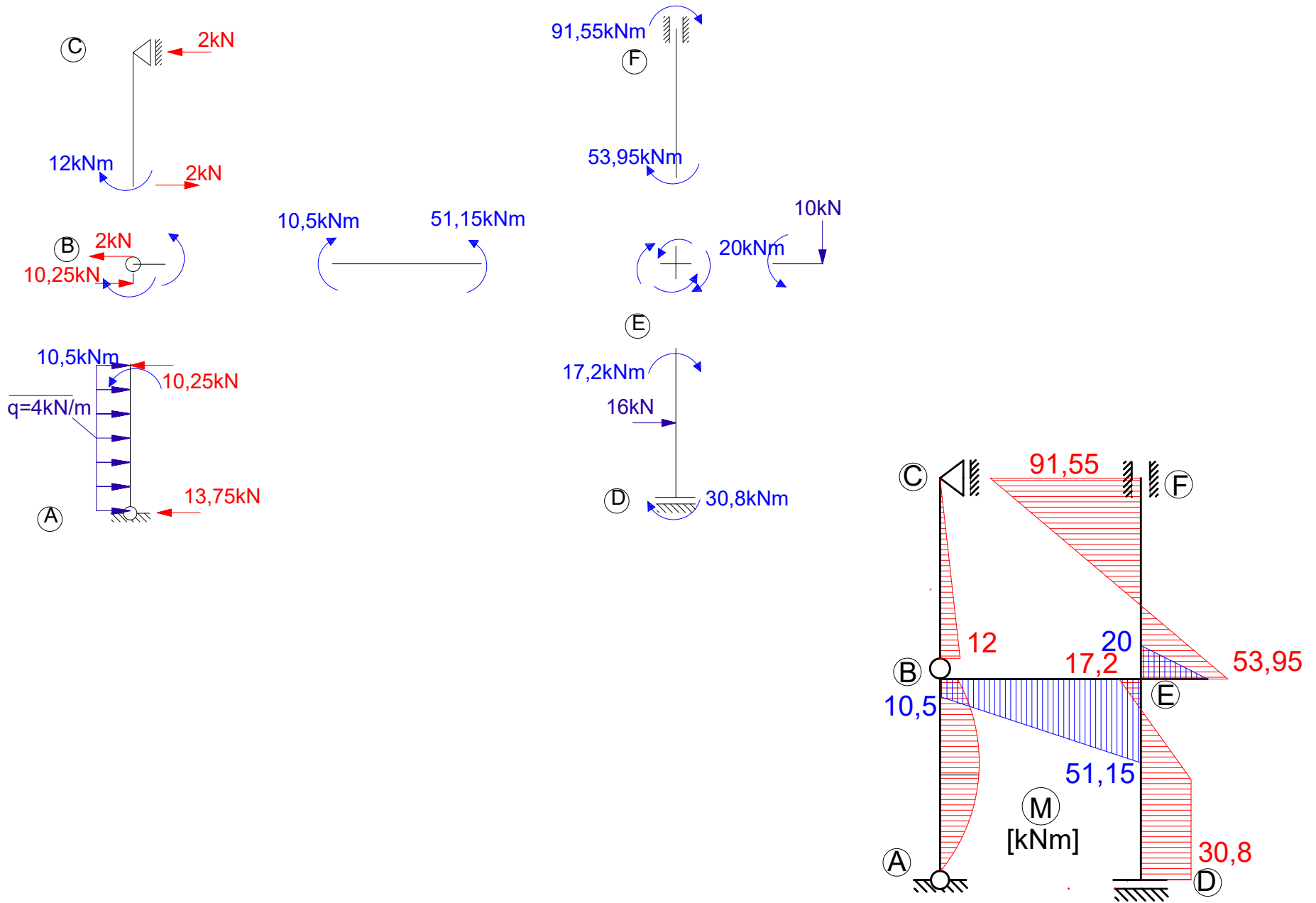

Wyznaczenie sił tnących i normalnych na podstawie wykresu M:

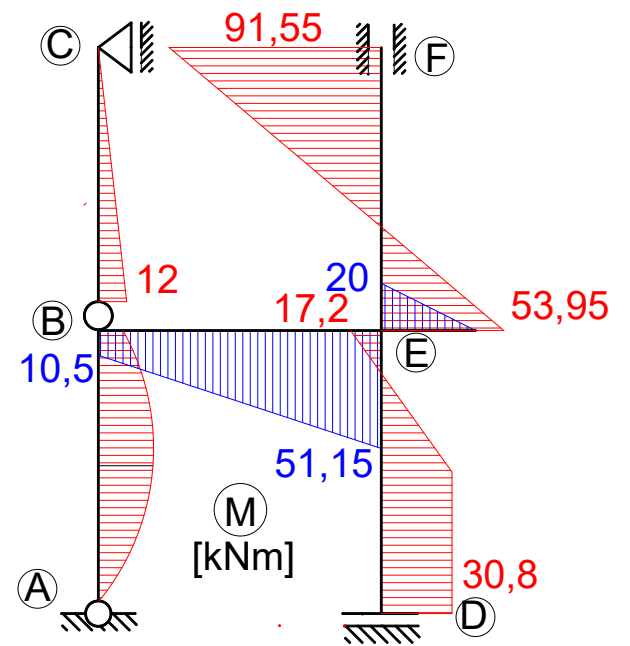
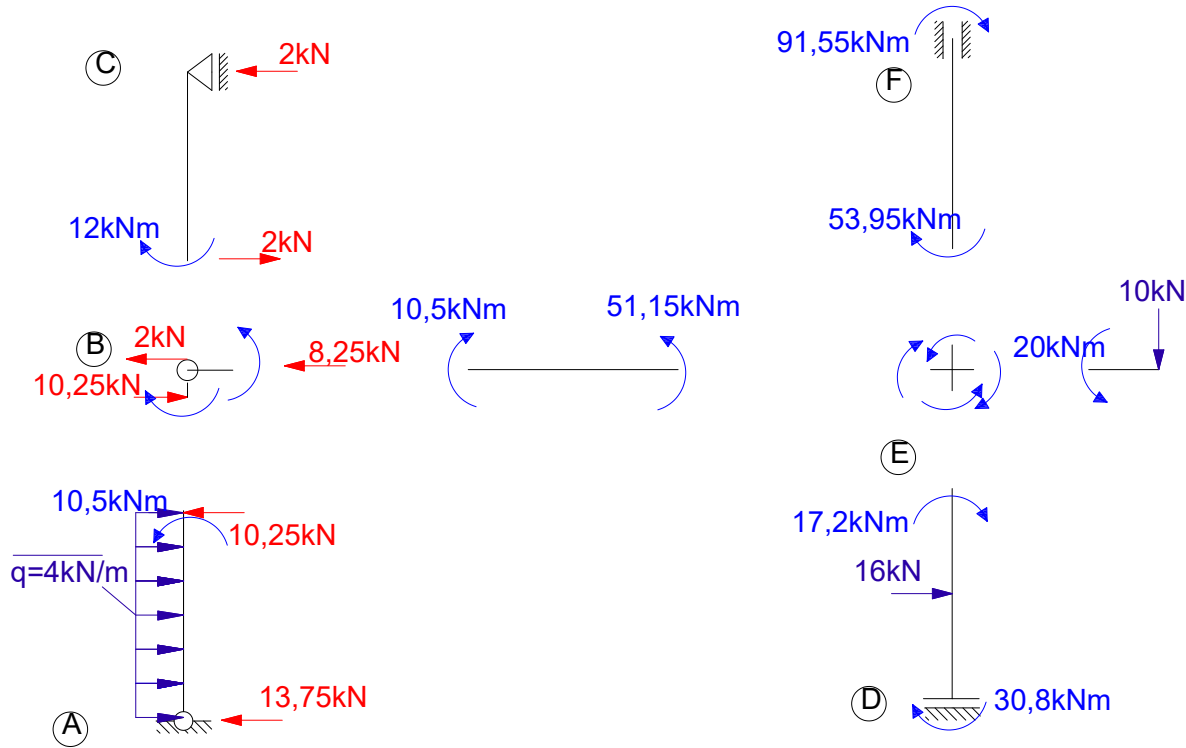

Wyznaczenie sił tnących i normalnych na podstawie wykresu M:

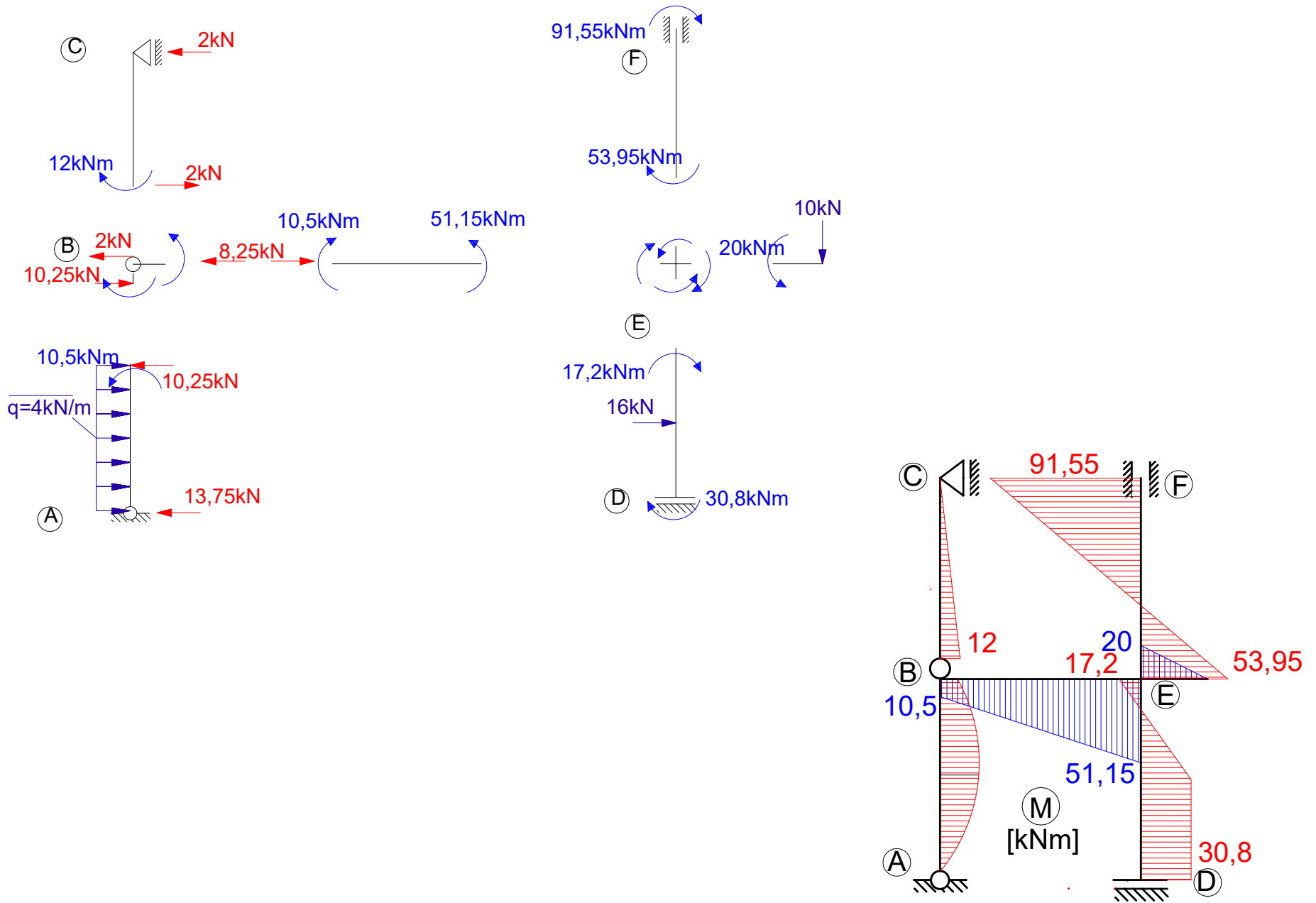

Wyznaczenie sił tnących i normalnych na podstawie wykresu M:

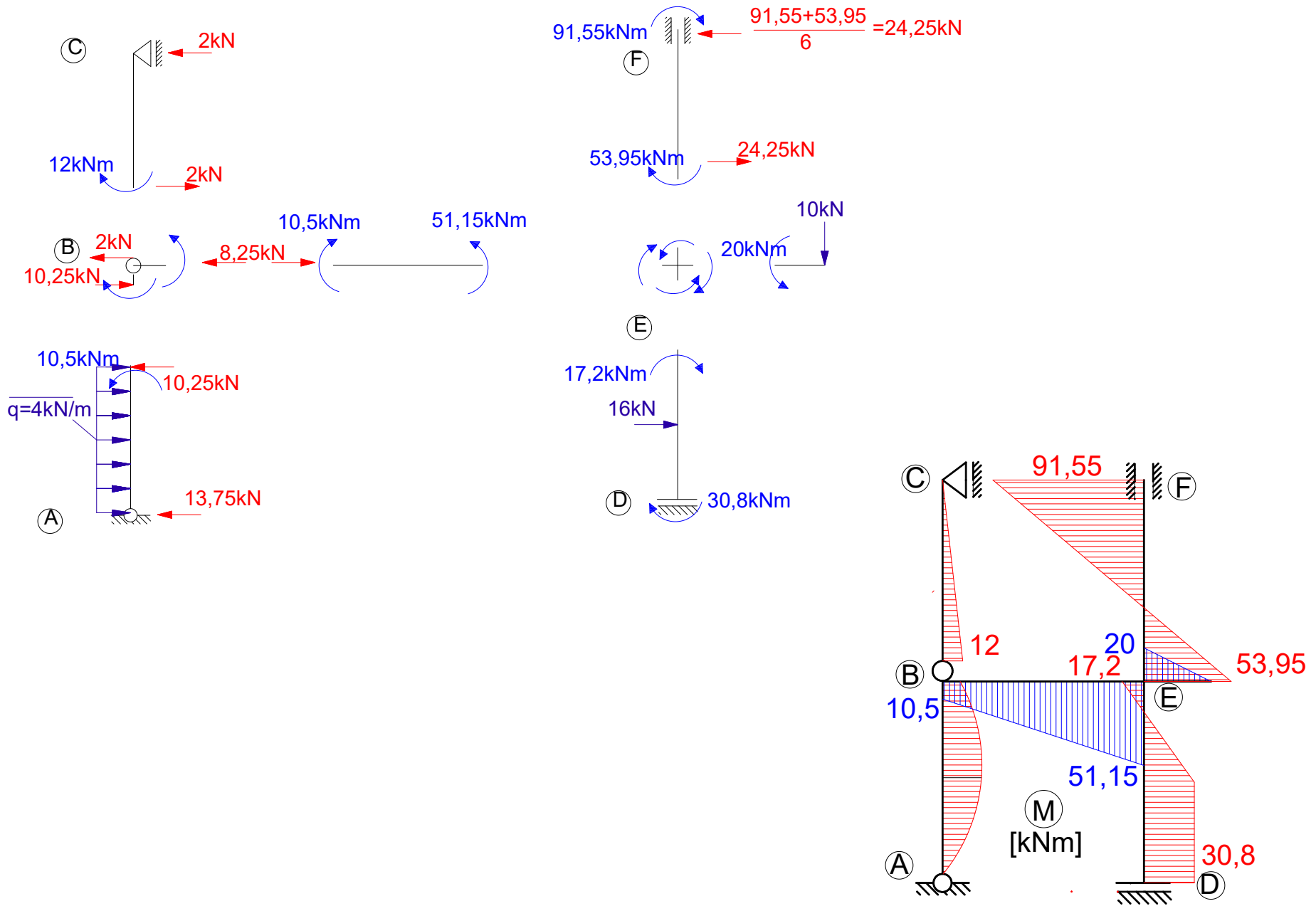

Wyznaczenie sił tnących i normalnych na podstawie wykresu M:

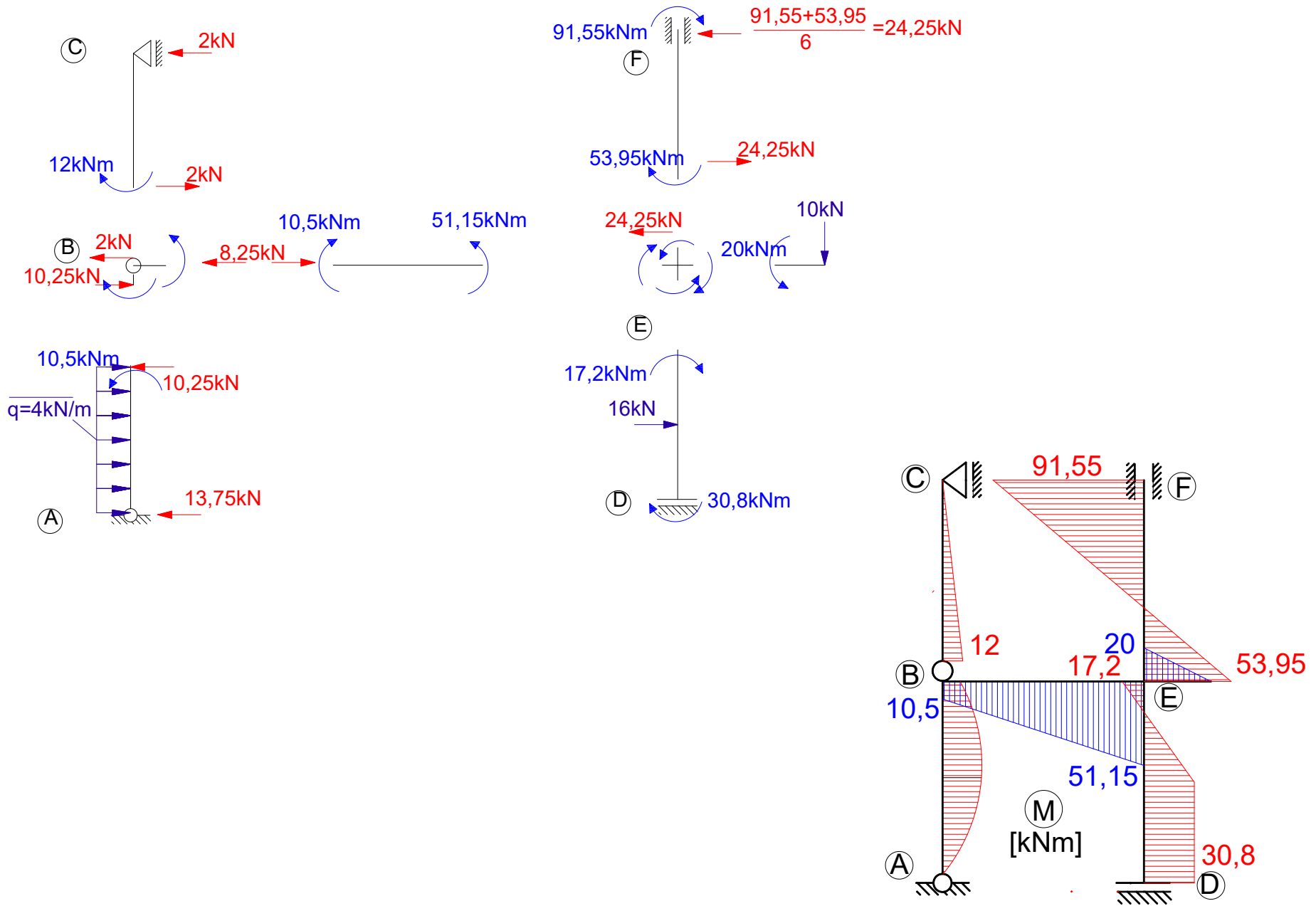

Wyznaczenie sił tnących i normalnych na podstawie wykresu M:

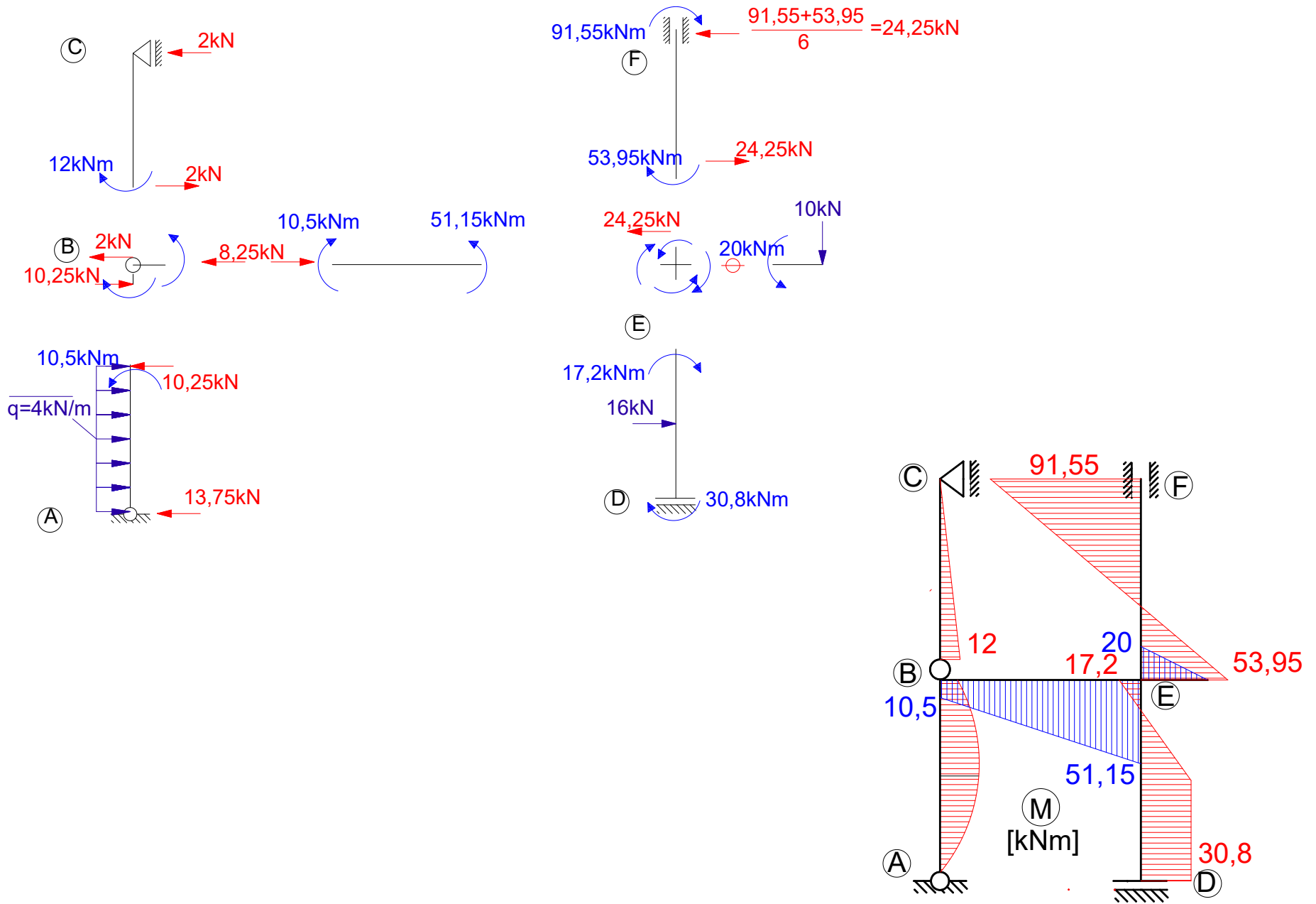

Wyznaczenie sił tnących i normalnych na podstawie wykresu M:

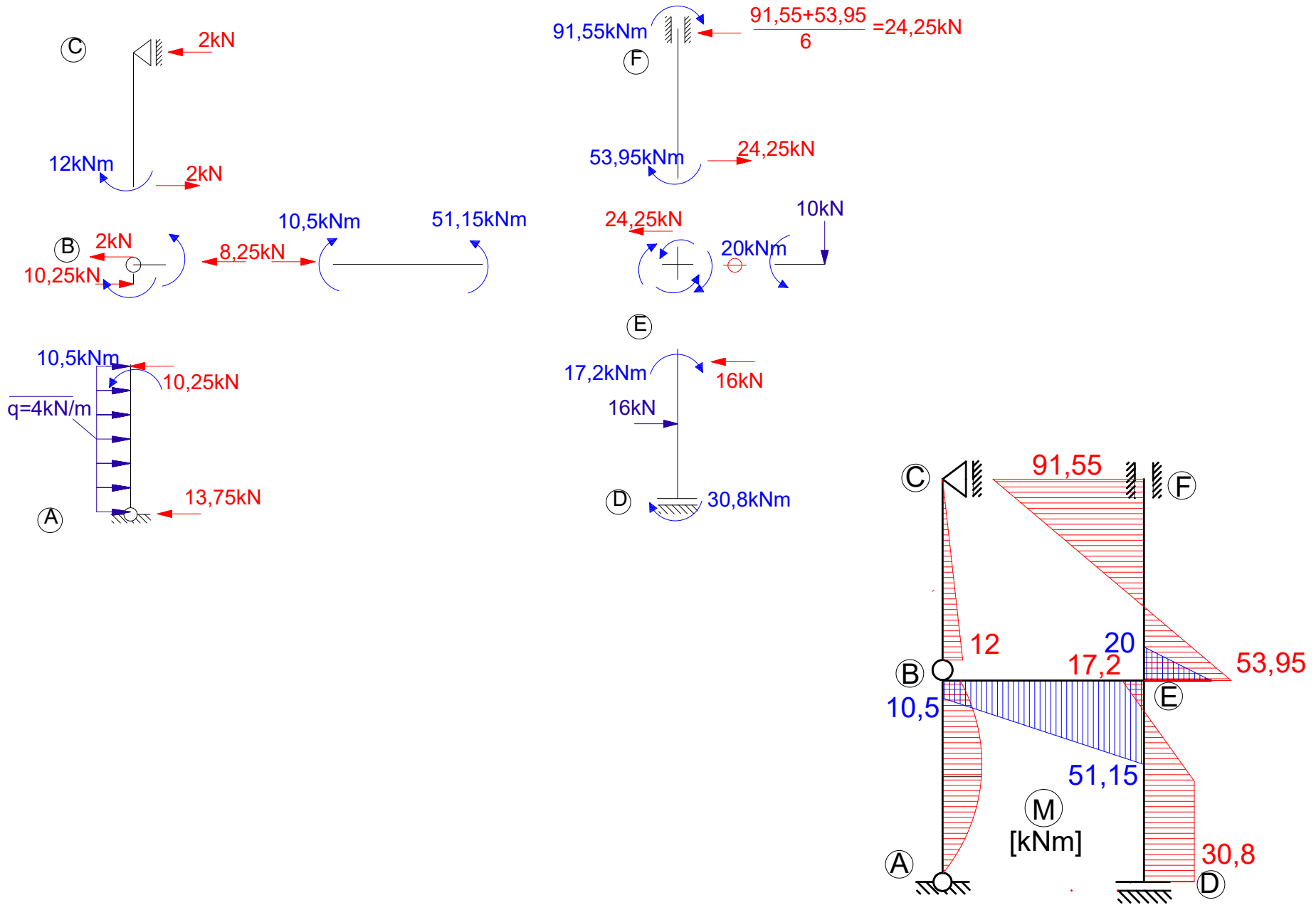

Wyznaczenie sił tnących i normalnych na podstawie wykresu M:

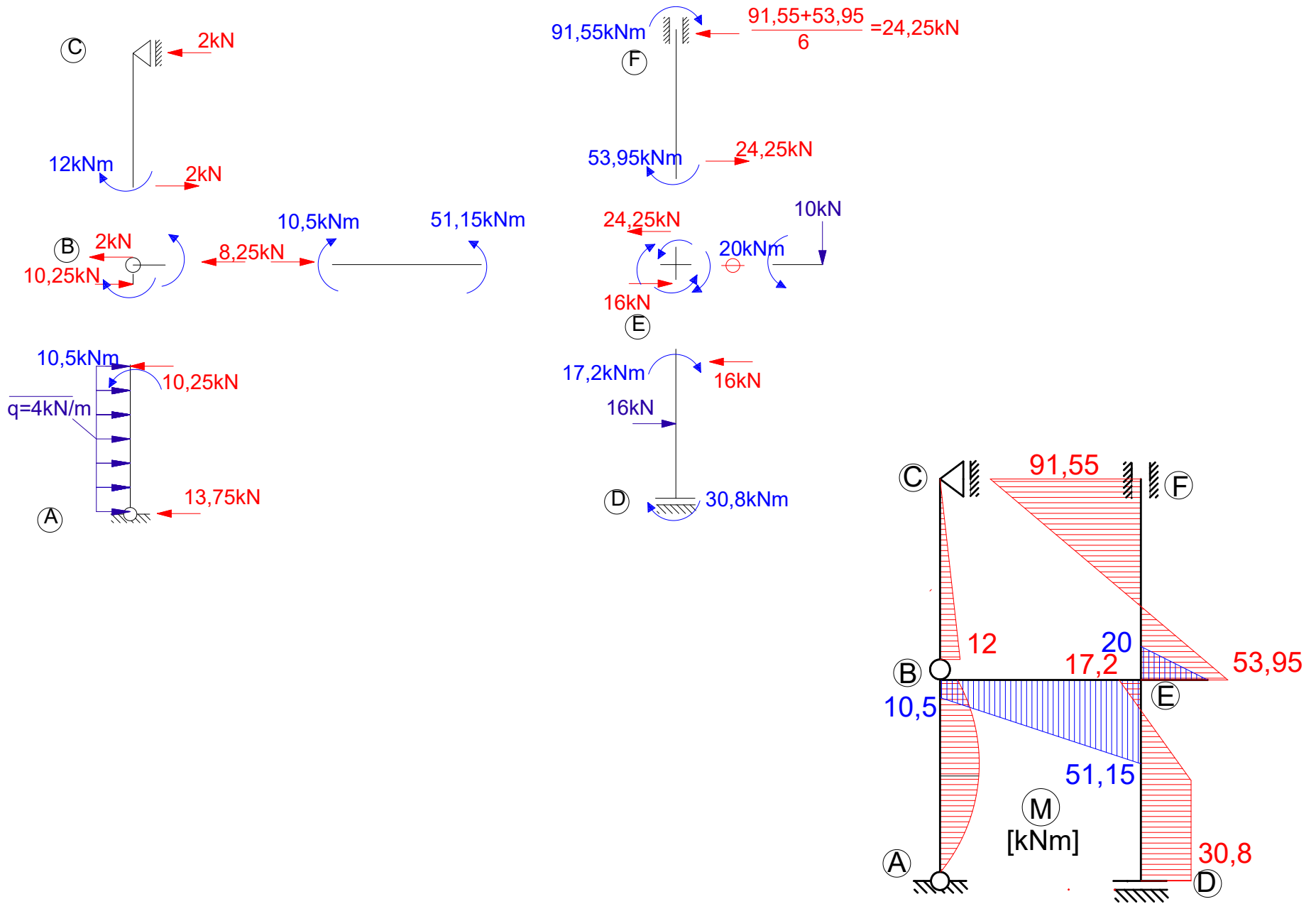

Wyznaczenie sił tnących i normalnych na podstawie wykresu M:

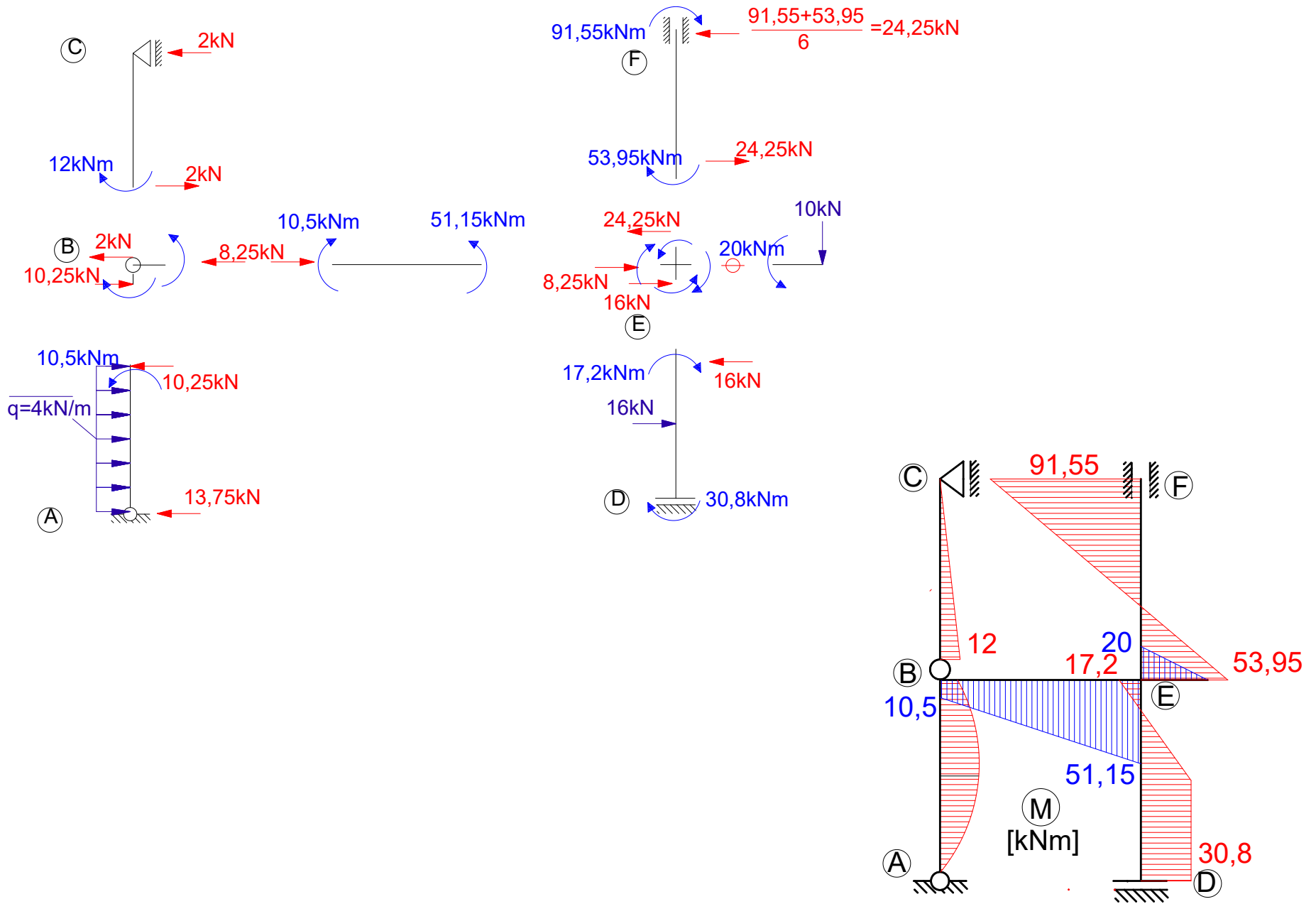

Wyznaczenie sił tnących i normalnych na podstawie wykresu M:

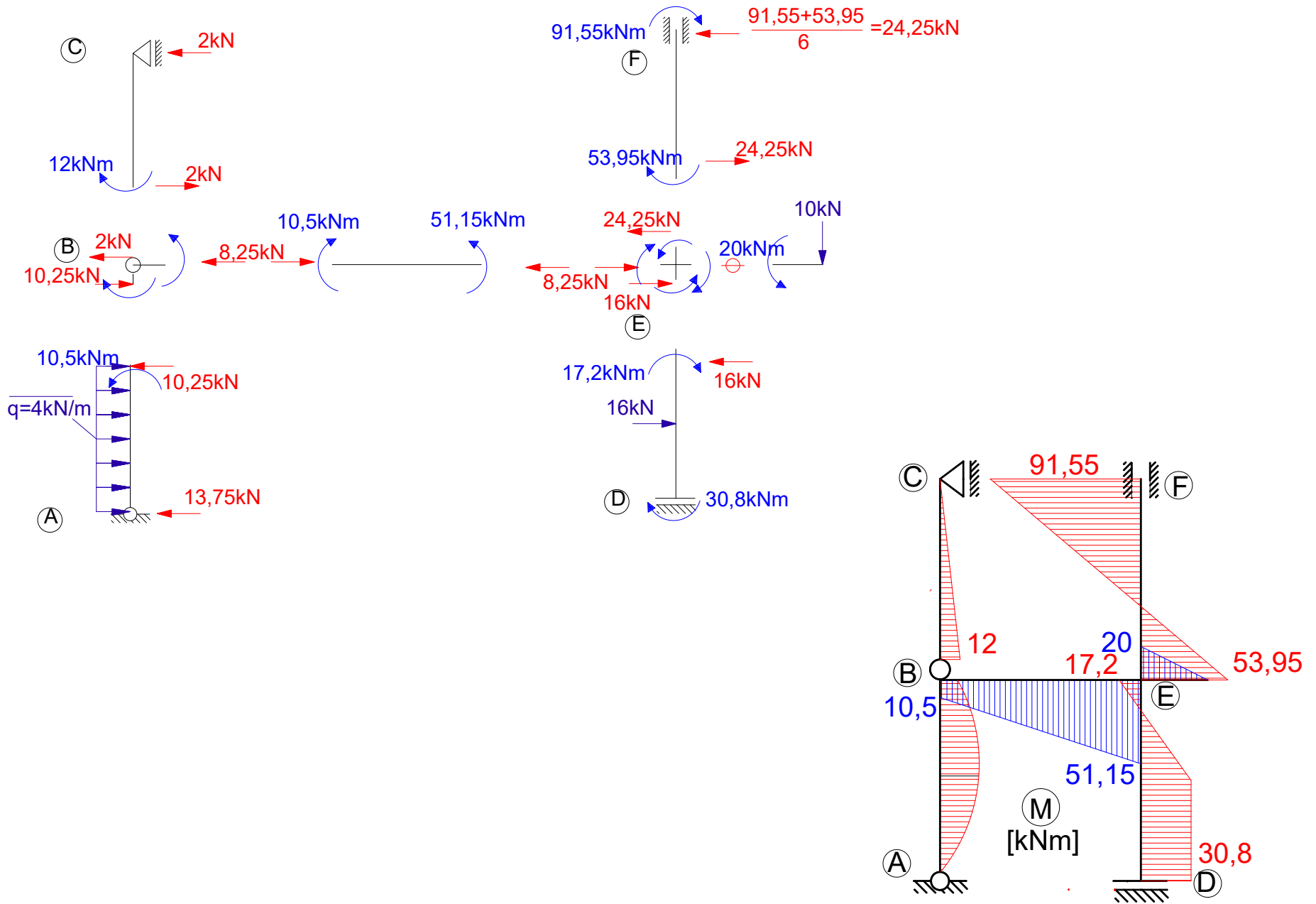

Wyznaczenie sił tnących i normalnych na podstawie wykresu M:

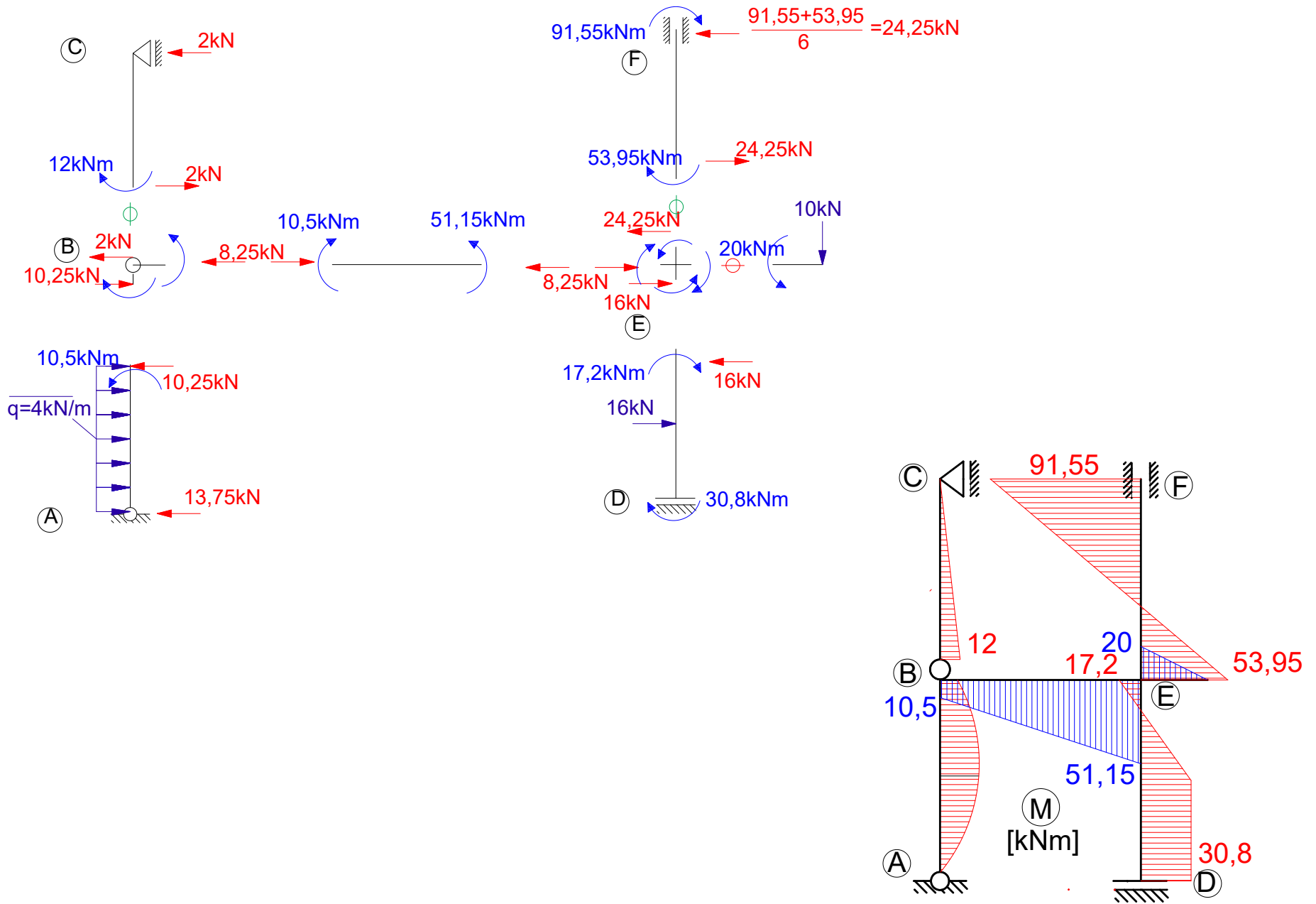

Wyznaczenie sił tnących i normalnych na podstawie wykresu M:

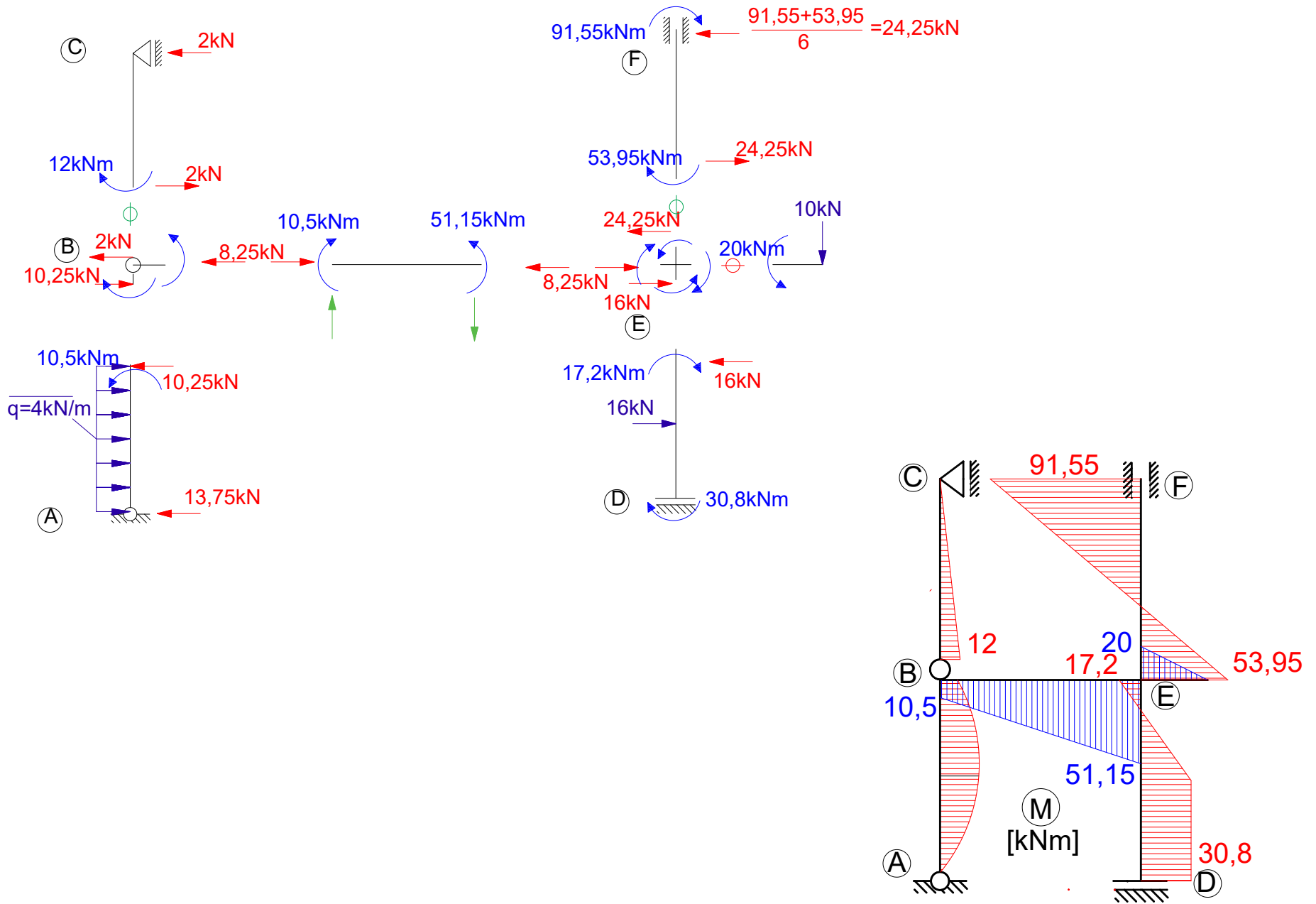

Wyznaczenie sił tnących i normalnych na podstawie wykresu M:

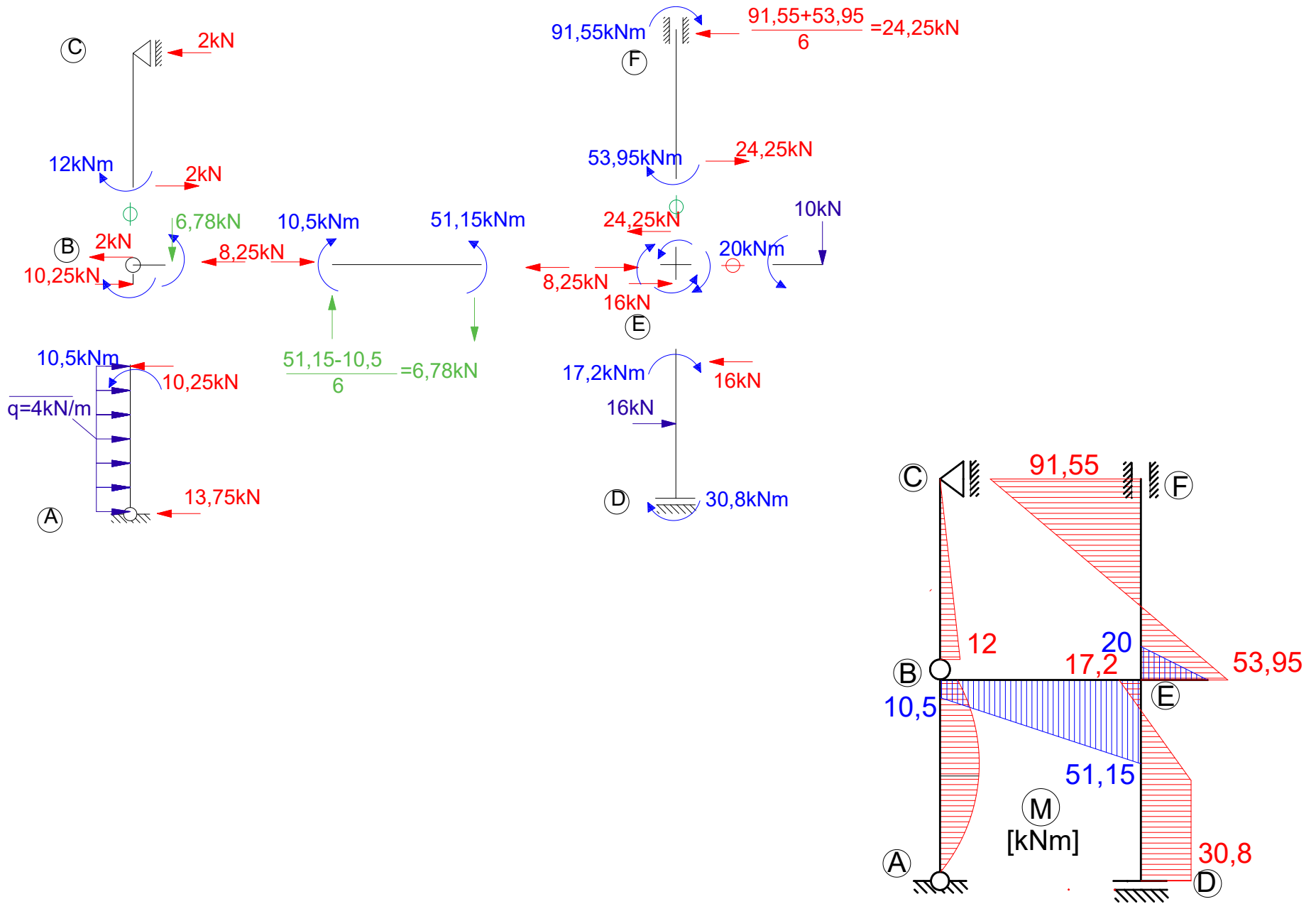

Wyznaczenie sił tnących i normalnych na podstawie wykresu M:

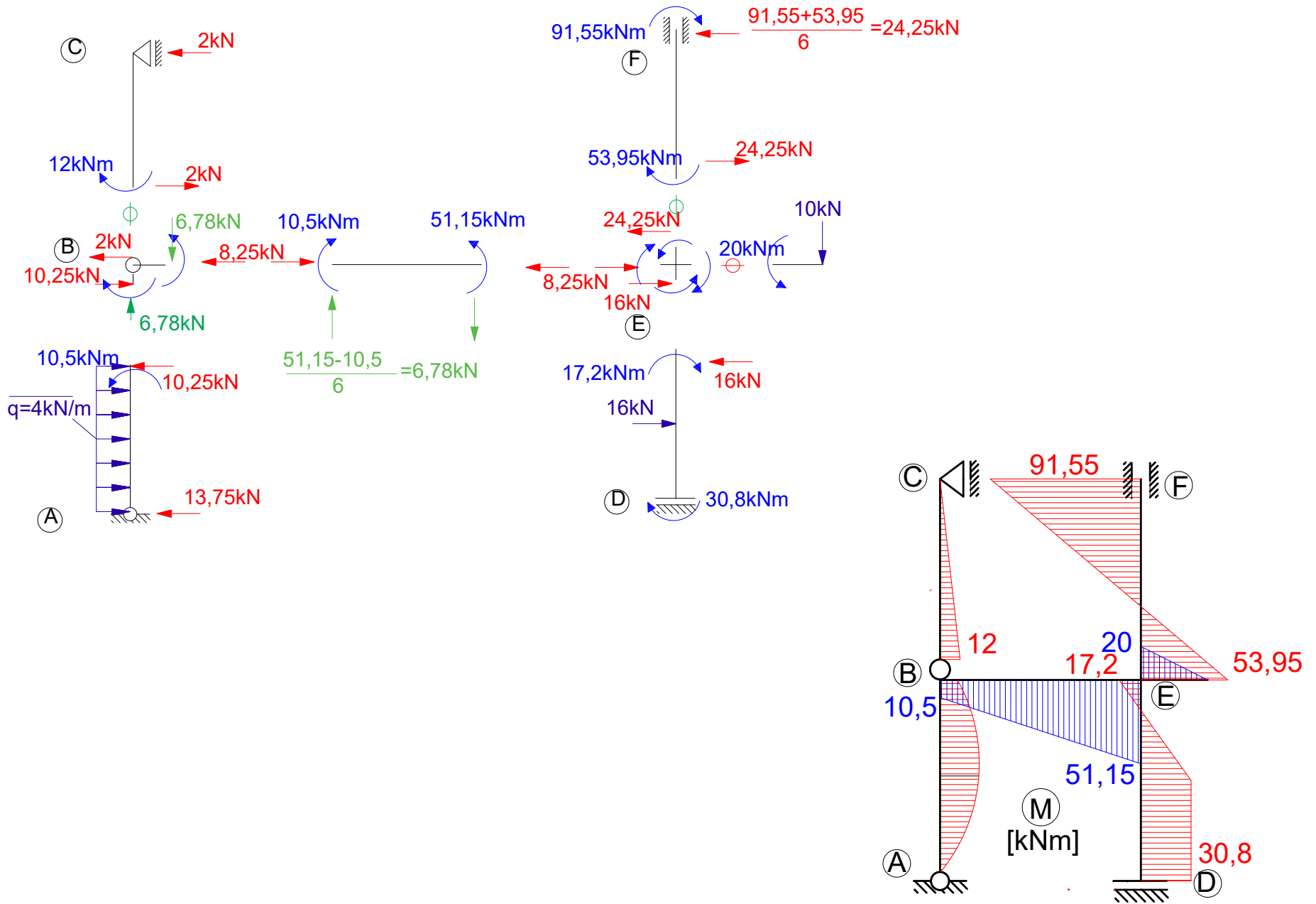

Wyznaczenie sił tnących i normalnych na podstawie wykresu M:

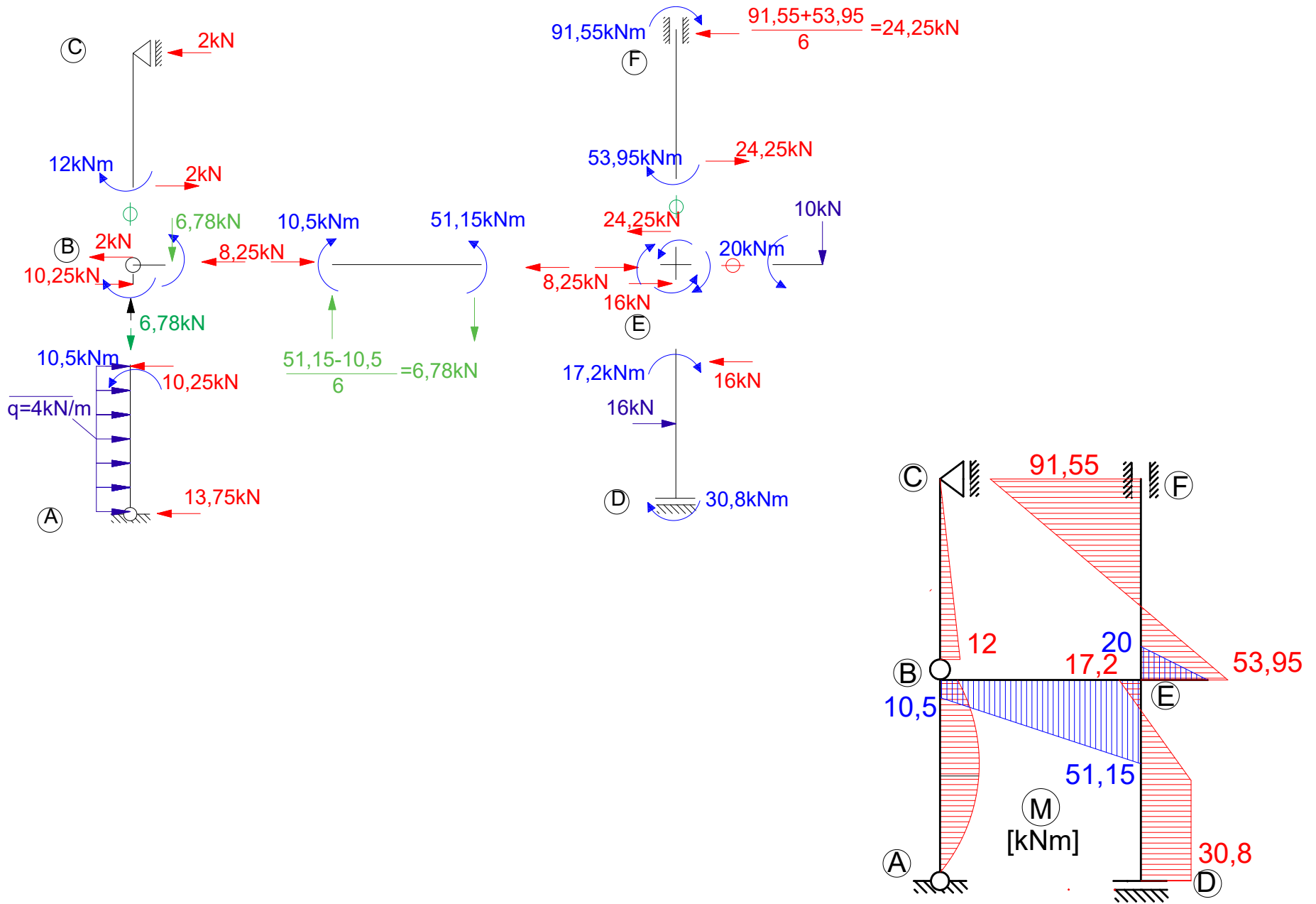

Wyznaczenie sił tnących i normalnych na podstawie wykresu M:

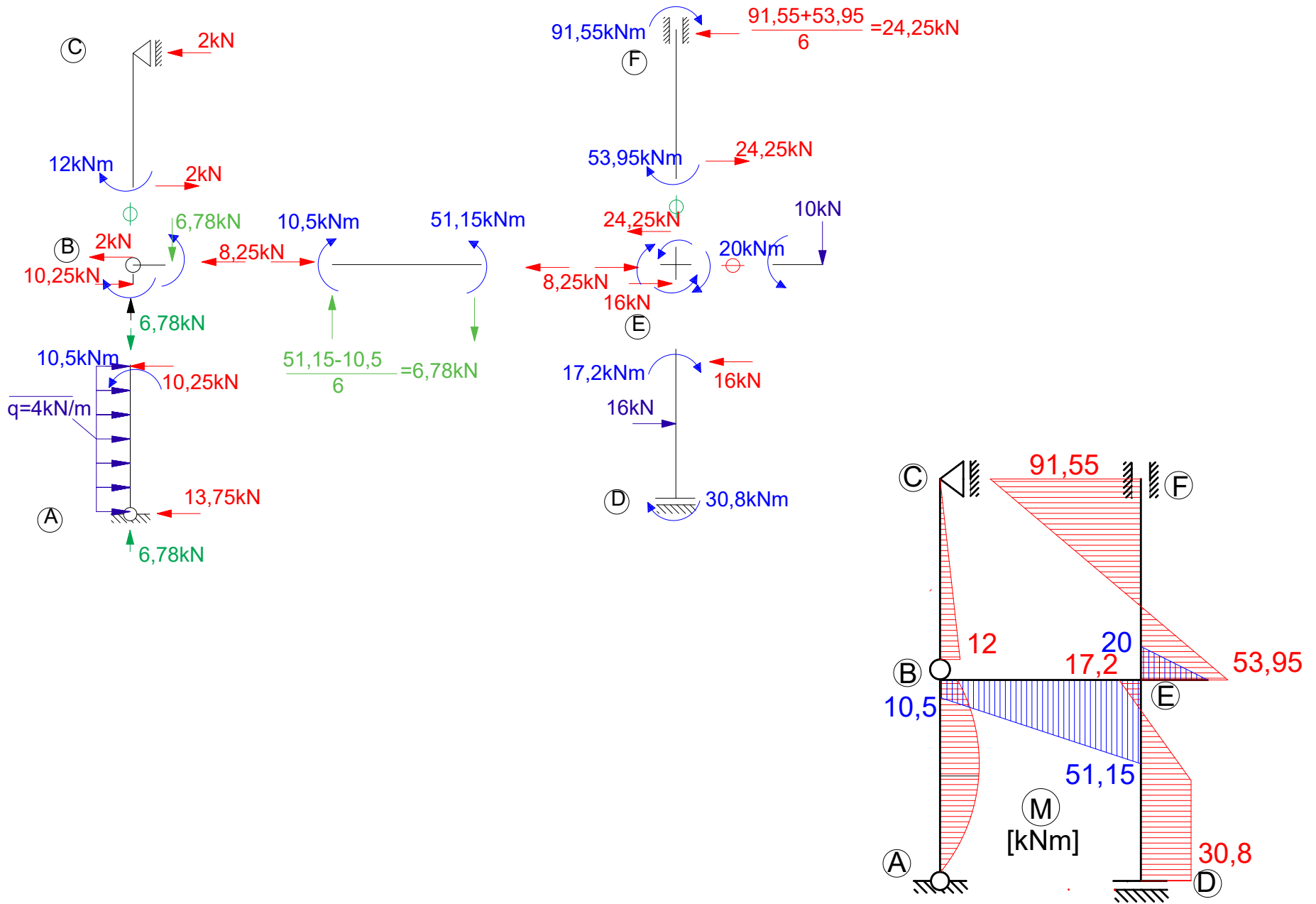

Wyznaczenie sił tnących i normalnych na podstawie wykresu M:

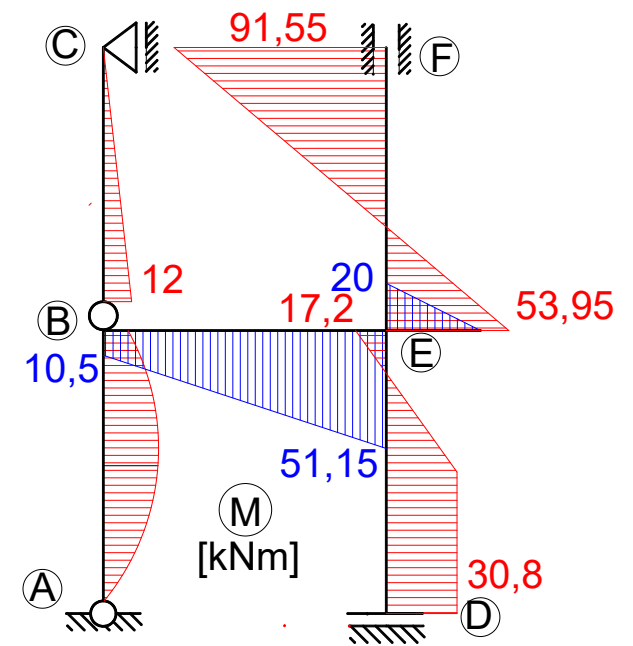
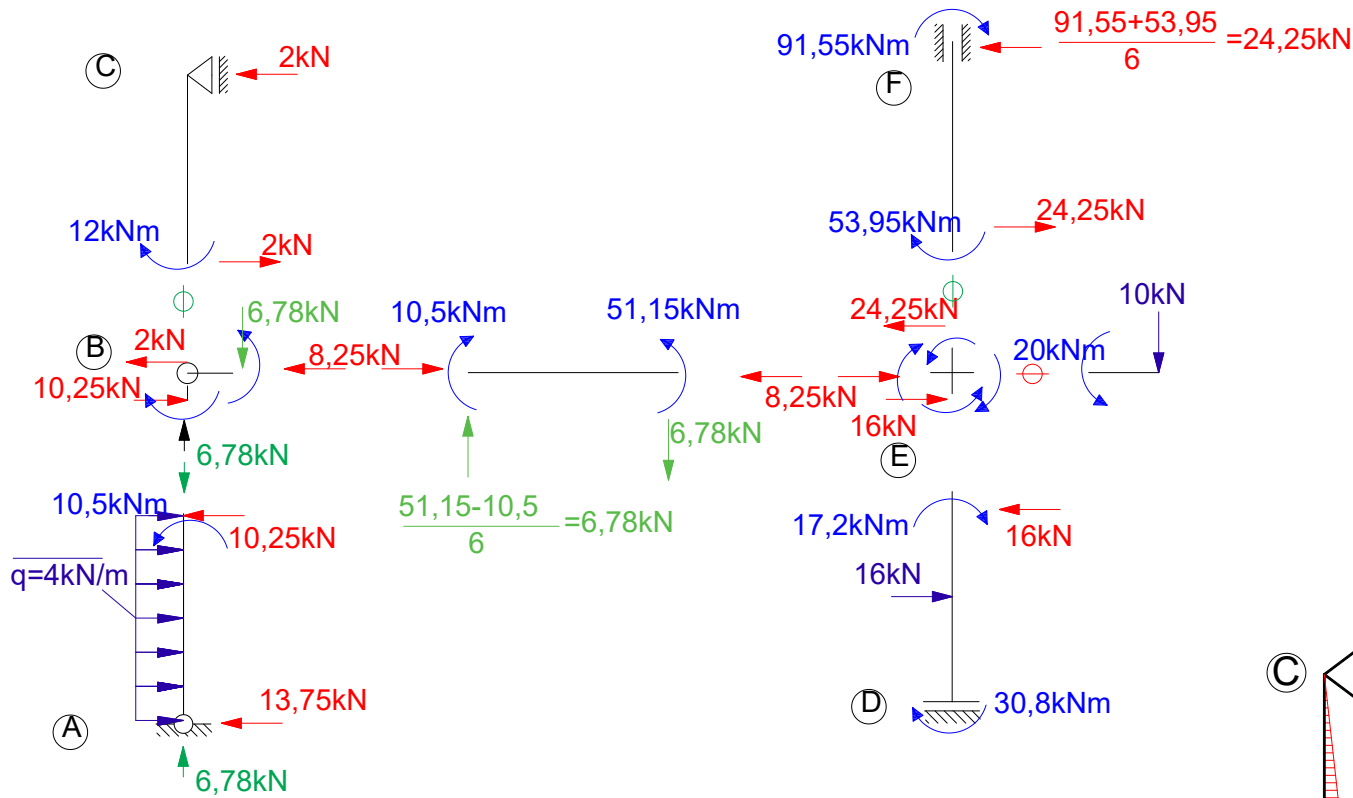

Wyznaczenie sił tnących i normalnych na podstawie wykresu M:

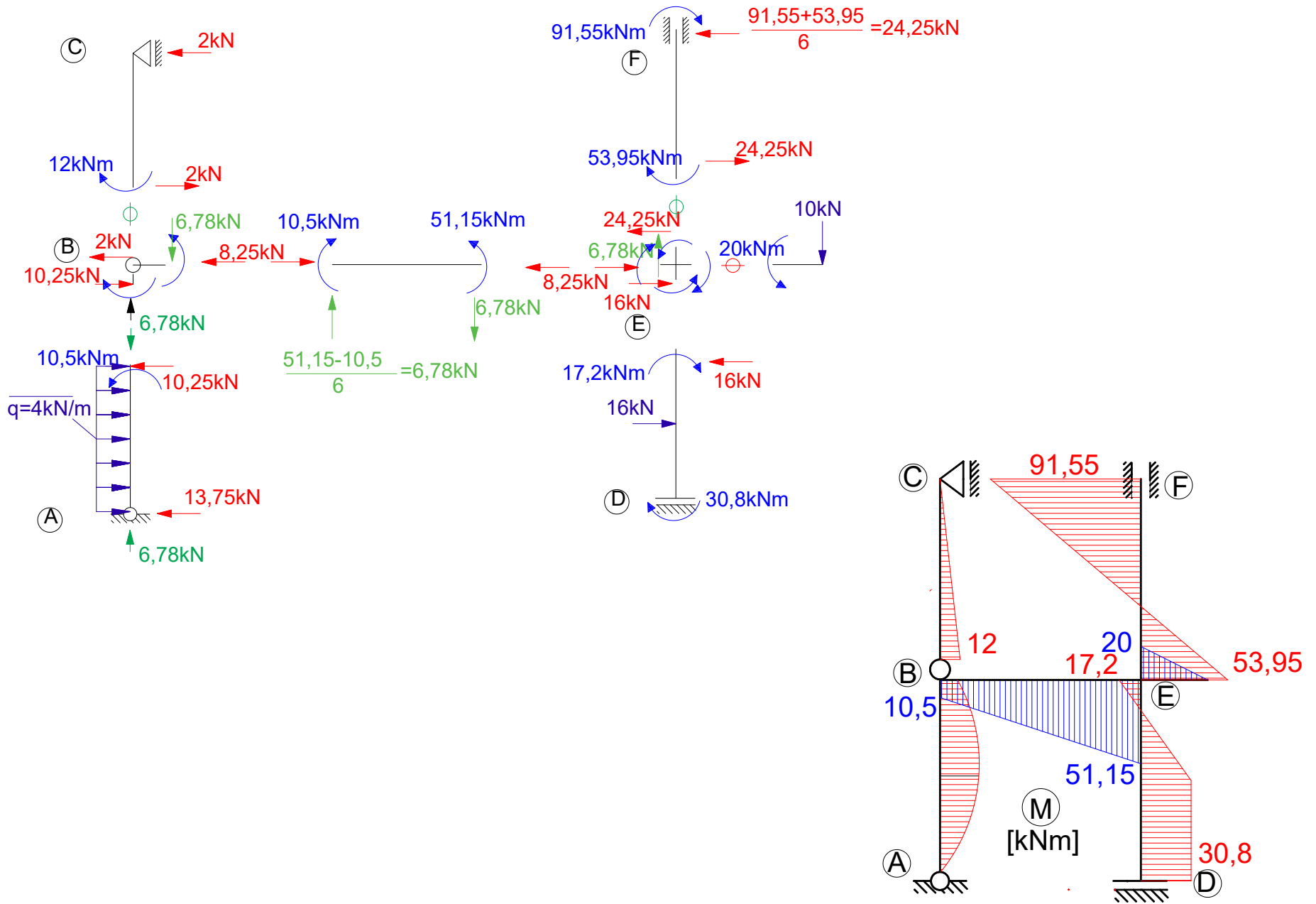

Wyznaczenie sił tnących i normalnych na podstawie wykresu M:

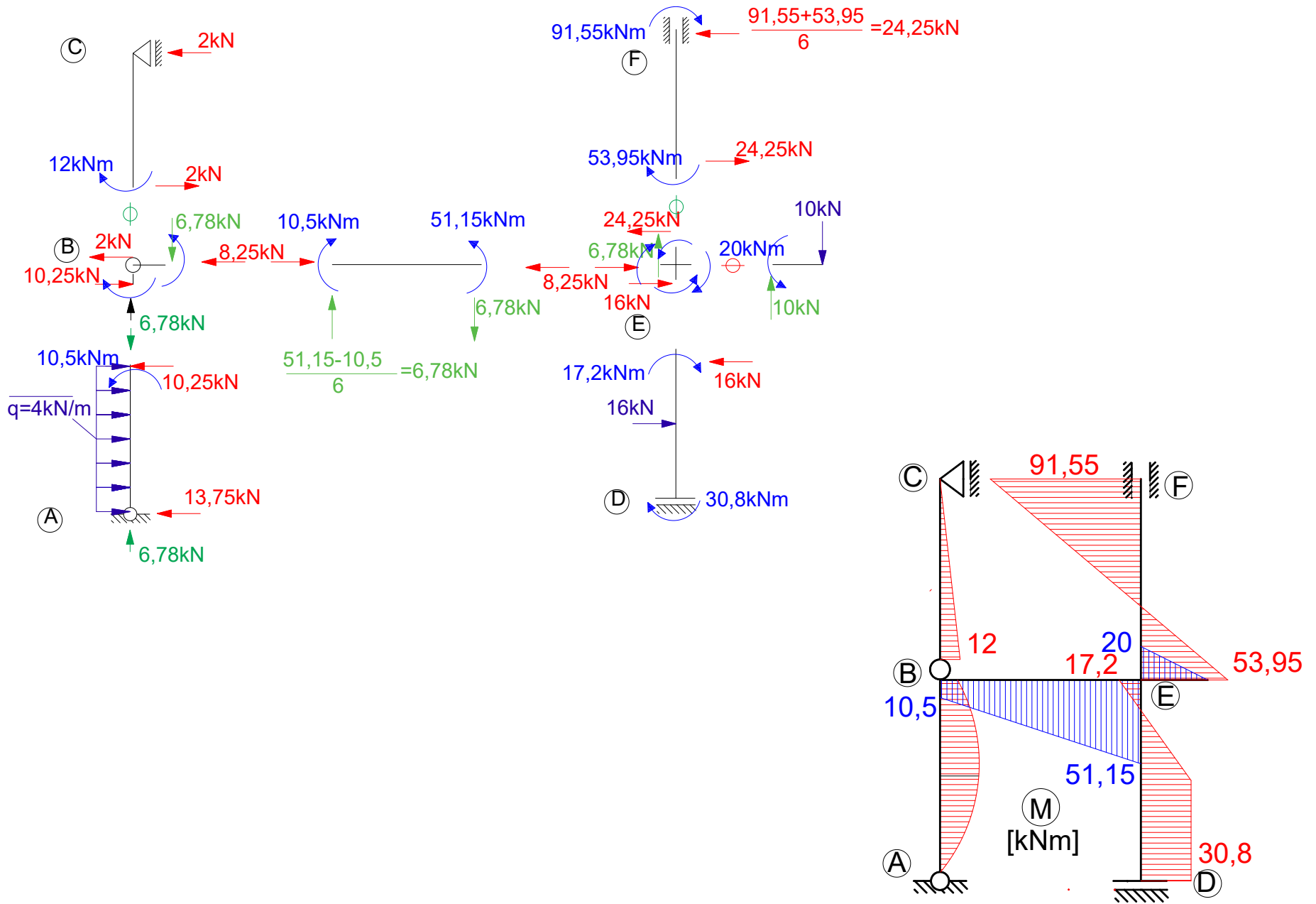

Wyznaczenie sił tnących i normalnych na podstawie wykresu M:

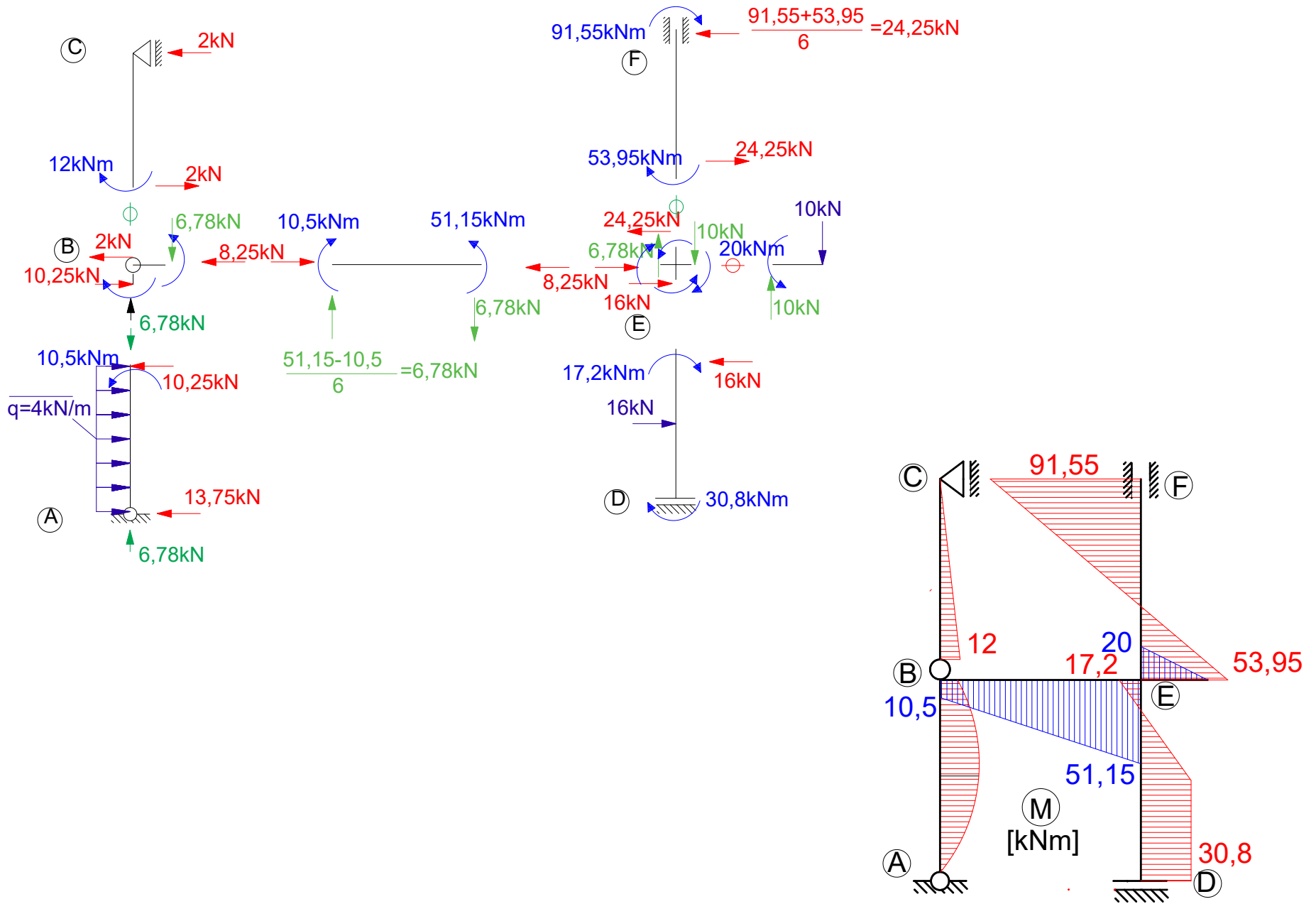

Wyznaczenie sił tnących i normalnych na podstawie wykresu M:

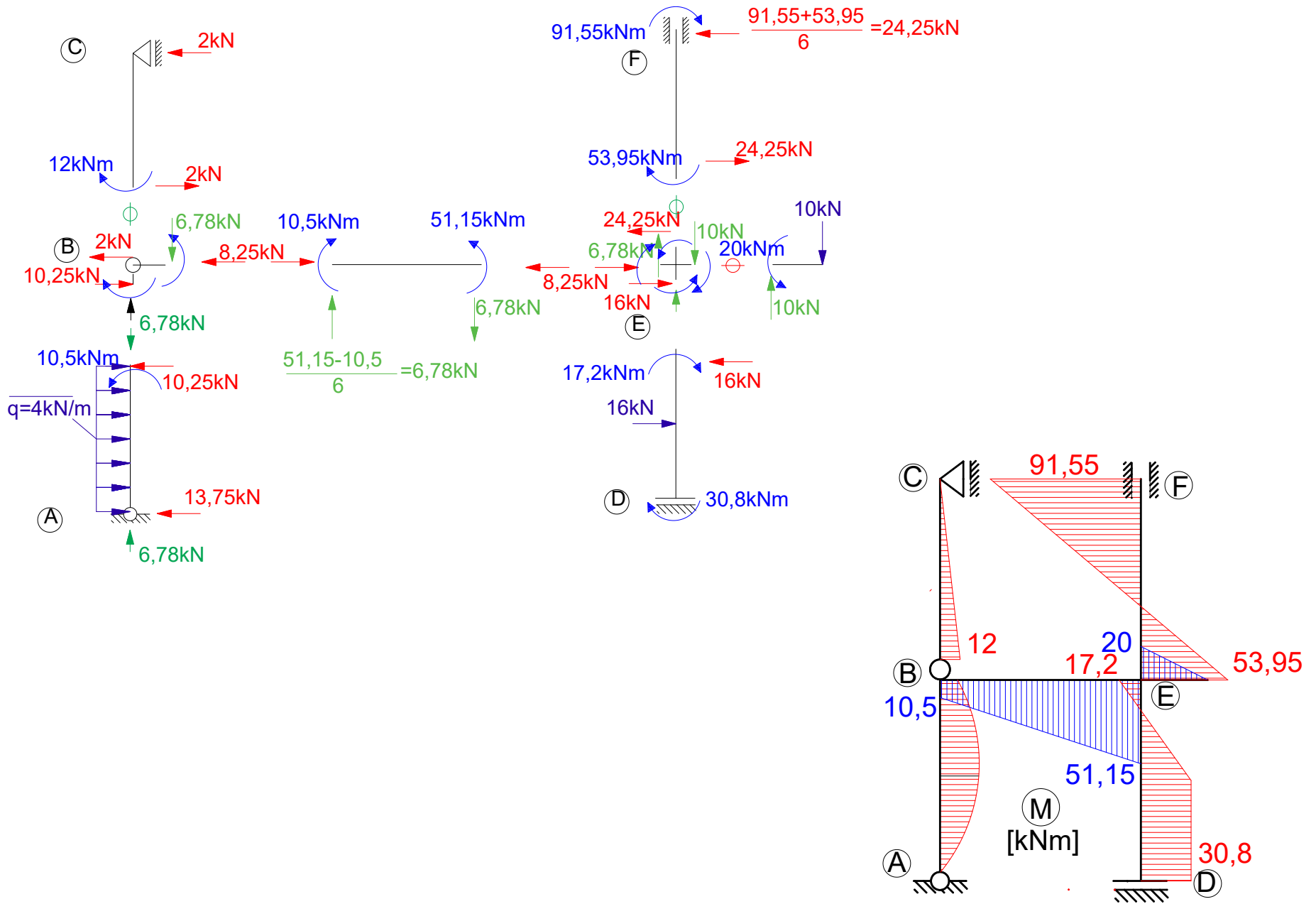

Wyznaczenie sił tnących i normalnych na podstawie wykresu M:

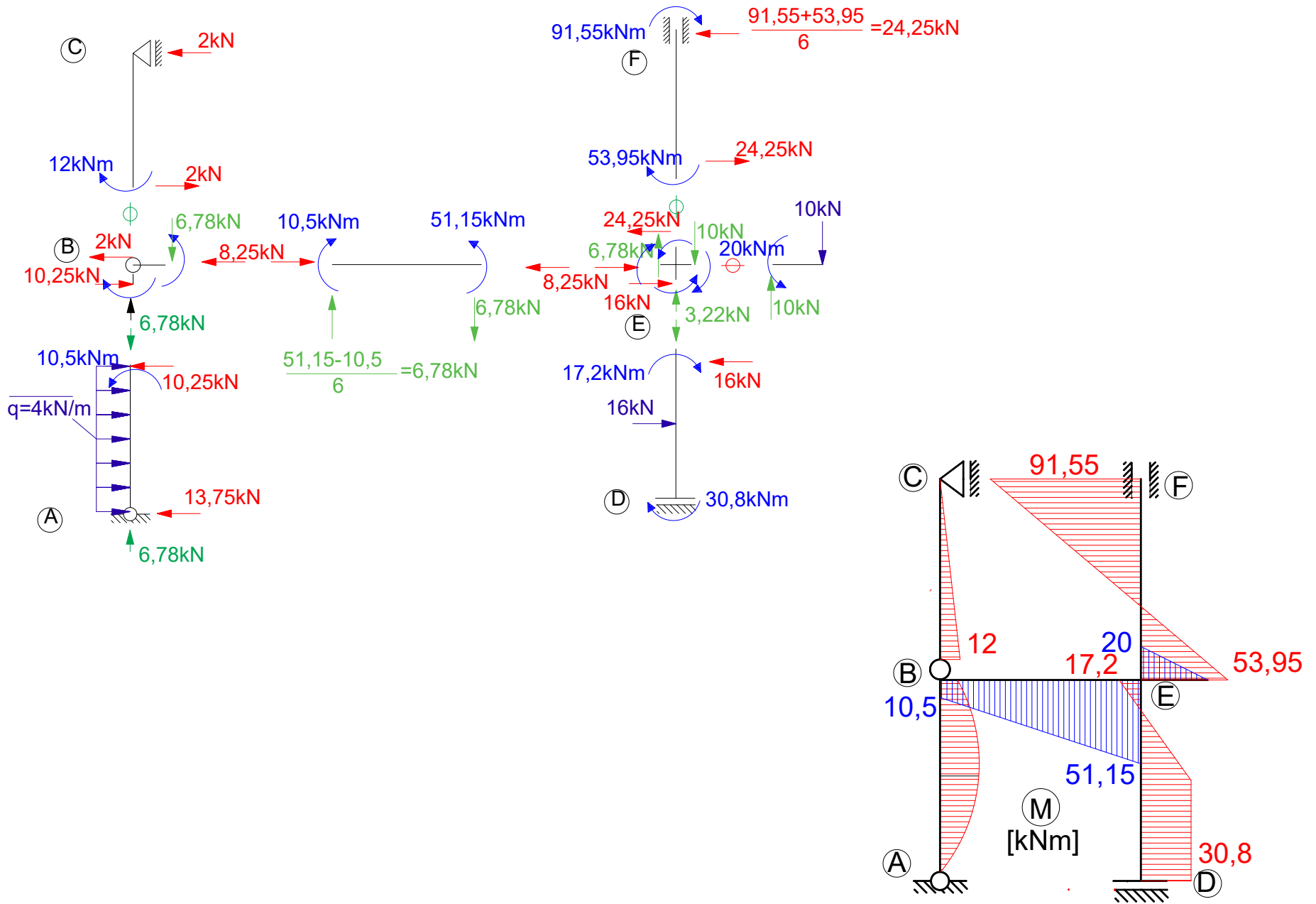

Wyznaczenie sił tnących i normalnych na podstawie wykresu M:

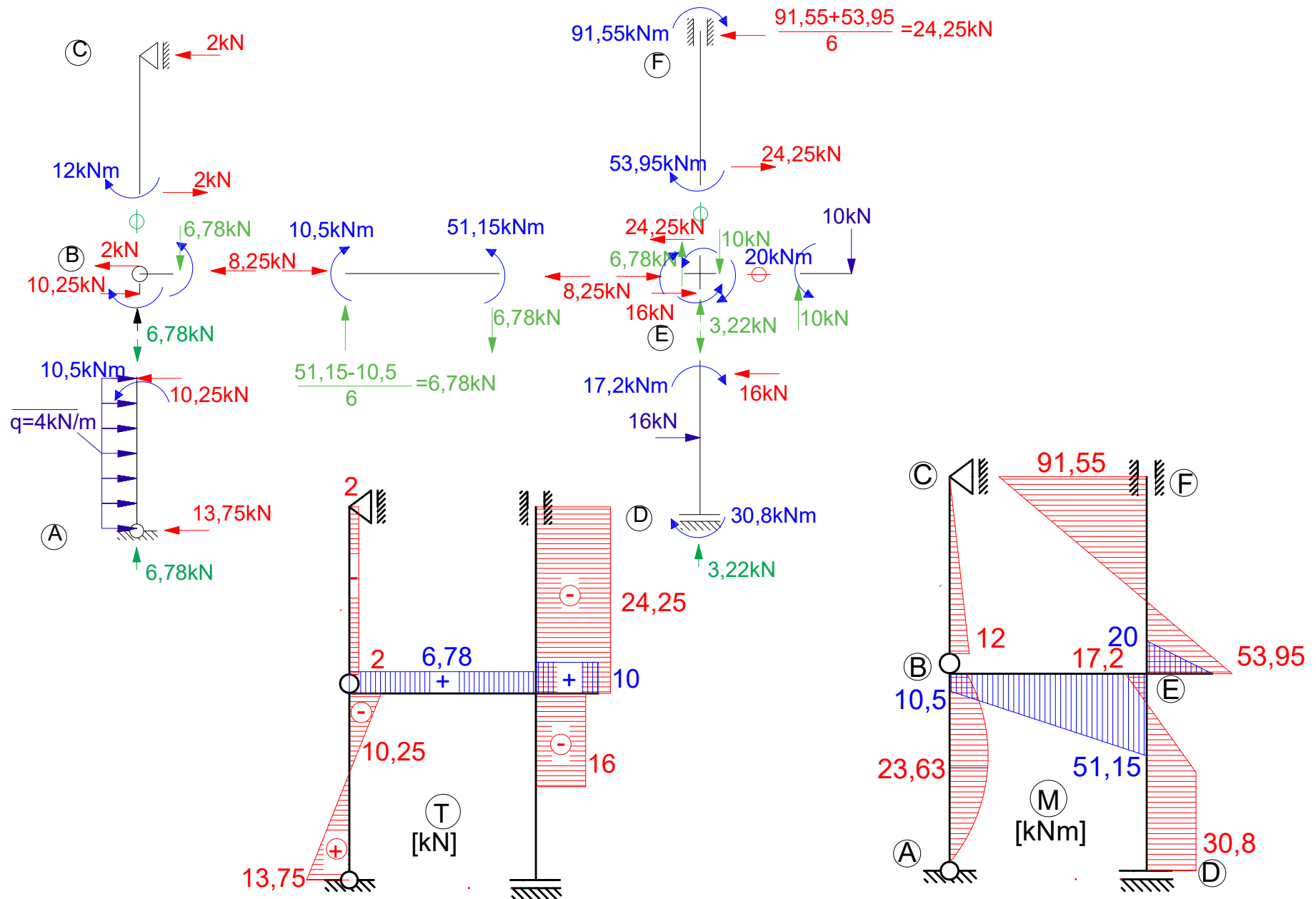

Wyznaczenie sił tnących i normalnych na podstawie wykresu M:

