

Zadanie: Narysuj wykres sił normalnych dla zadanej kratownicy i policz przemieszczenie poziome węzła G. Zadanie rozwiąż metodą sił.

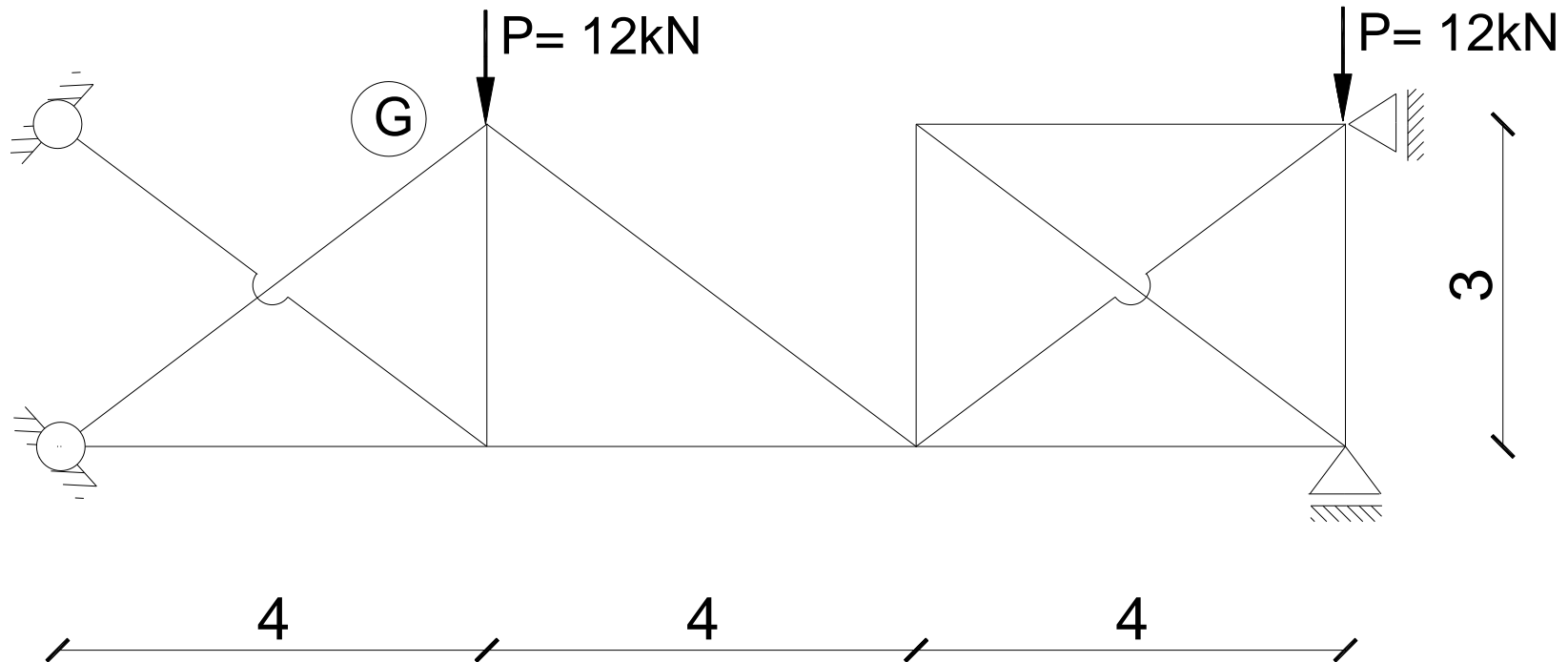

Oznaczenie prętów:

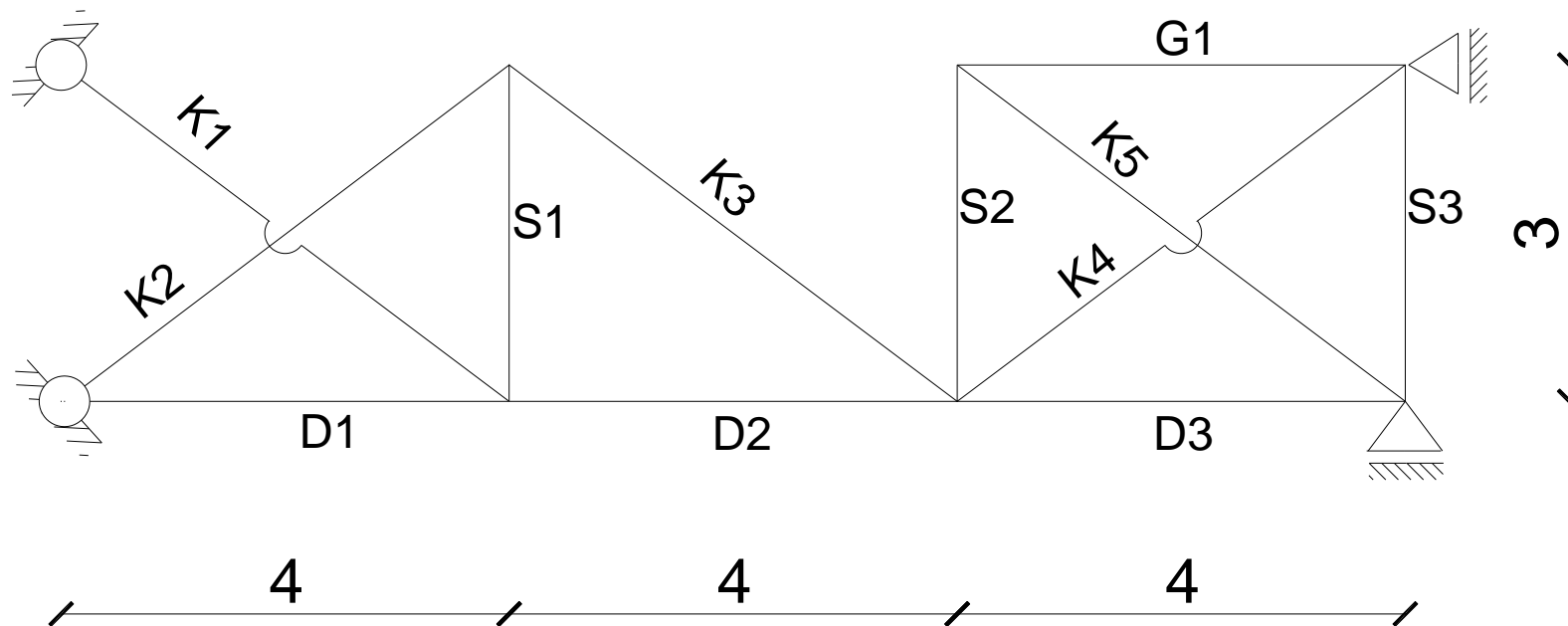

Stopień statycznej niewyznaczalności:

$$n_s = l_r + l_{pr} - 2 \cdot w = 6 + 12 - 2 \cdot 8 = 2$$

Dobór schematu podstawowego:

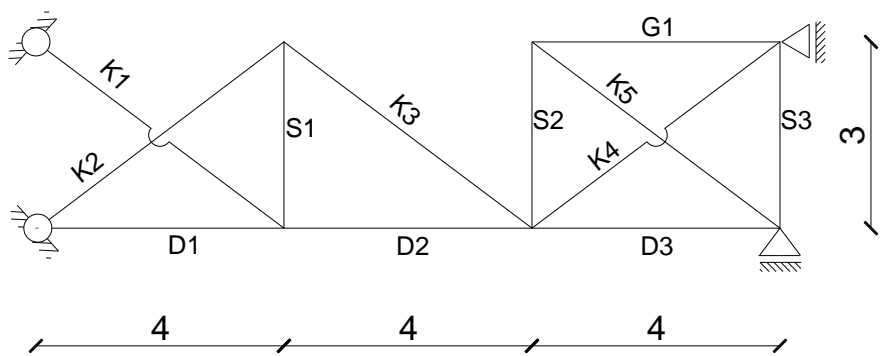
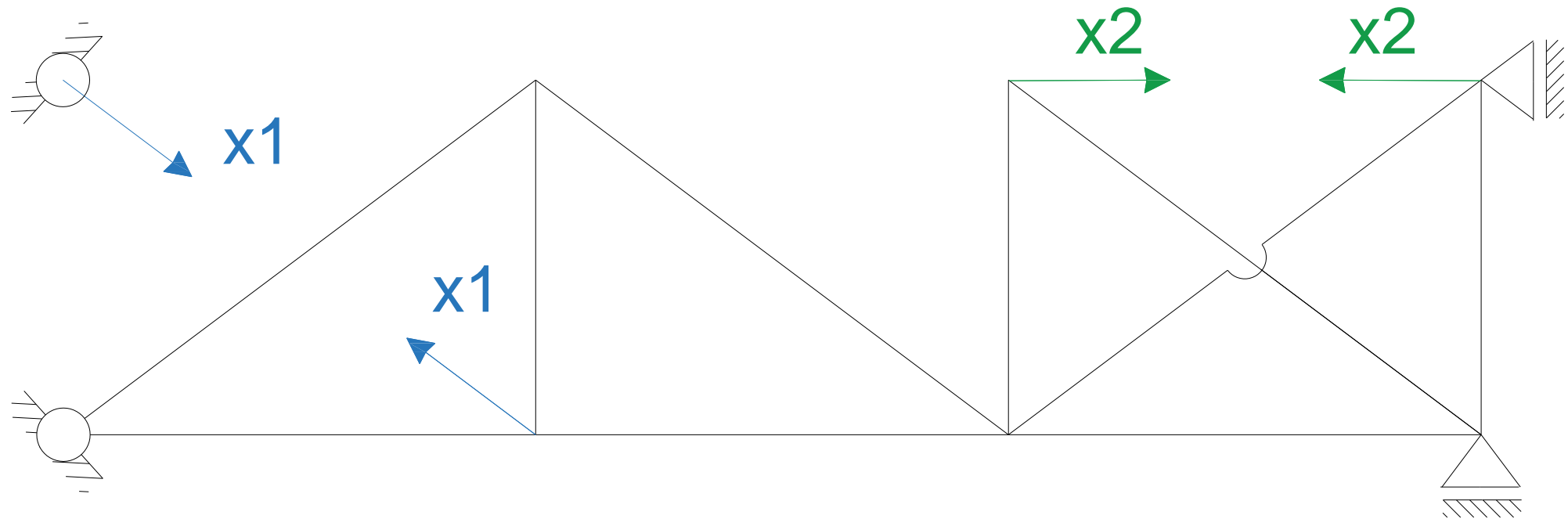

Wykresy: stan $x_1=1$, siły N1

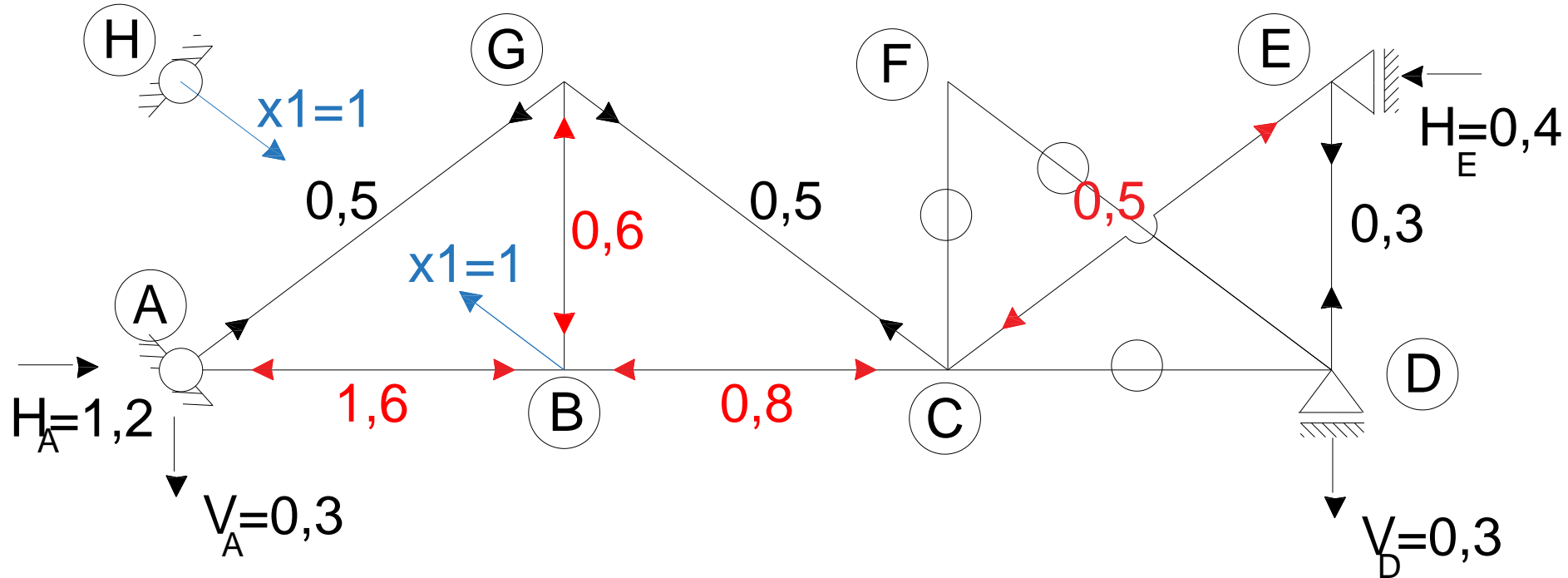

pręt	L/EA	N1
D1	4	-1,6
D2	4	-0,8
D3	4	0
G1	4	0
S1	3	-0,6
S2	3	0
S3	3	0,3
K1	5	1
K2	5	0,5
K3	5	0,5
K4	5	-0,5
K5	5	0

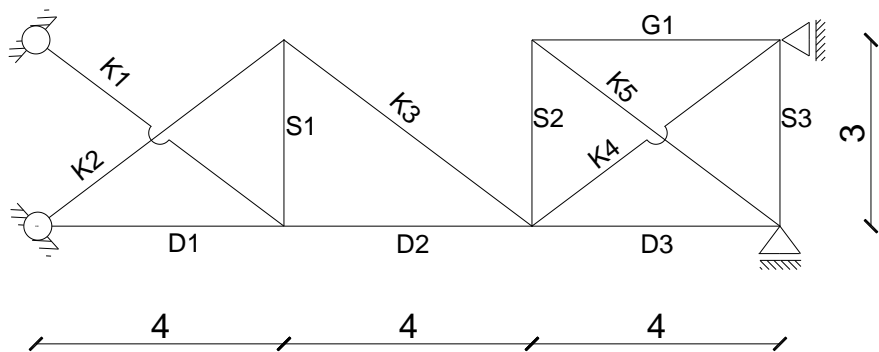

Wykresy: stan $x_2=1$, siły N2

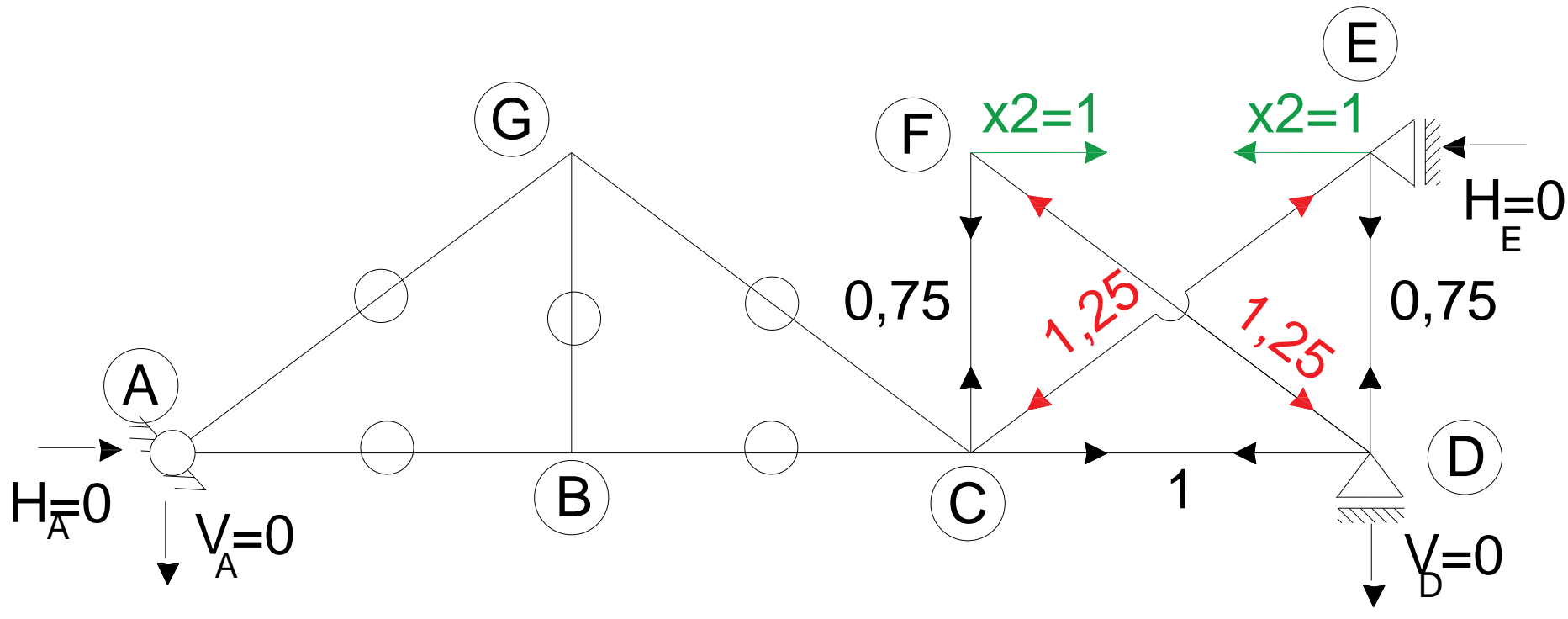

pręt	L/EA	N2
D1	4	0
D2	4	0
D3	4	1
G1	4	1
S1	3	0
S2	3	0,75
S3	3	0,75
K1	5	0
K2	5	0
K3	5	0
K4	5	-1,25
K5	5	-1,25

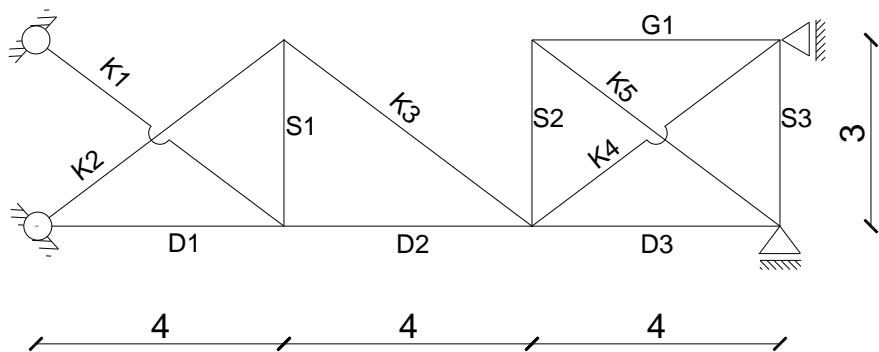

$$\sum R_x = x_2 + K5 \cdot \cos \alpha = 0$$

$$K5 = -\frac{x_2}{\cos \alpha} = -1 \cdot \frac{5}{4} = -1,25$$

$$\sum R_y = -S2 - K5 \cdot \sin \alpha = 0$$

$$S2 = -K5 \cdot \sin \alpha = -\left(-\frac{5}{4}\right) \cdot \frac{3}{5} = \frac{3}{4} = 0,75$$

Wykresy: obciążenie zewnętrzne – siły N0 [kN]

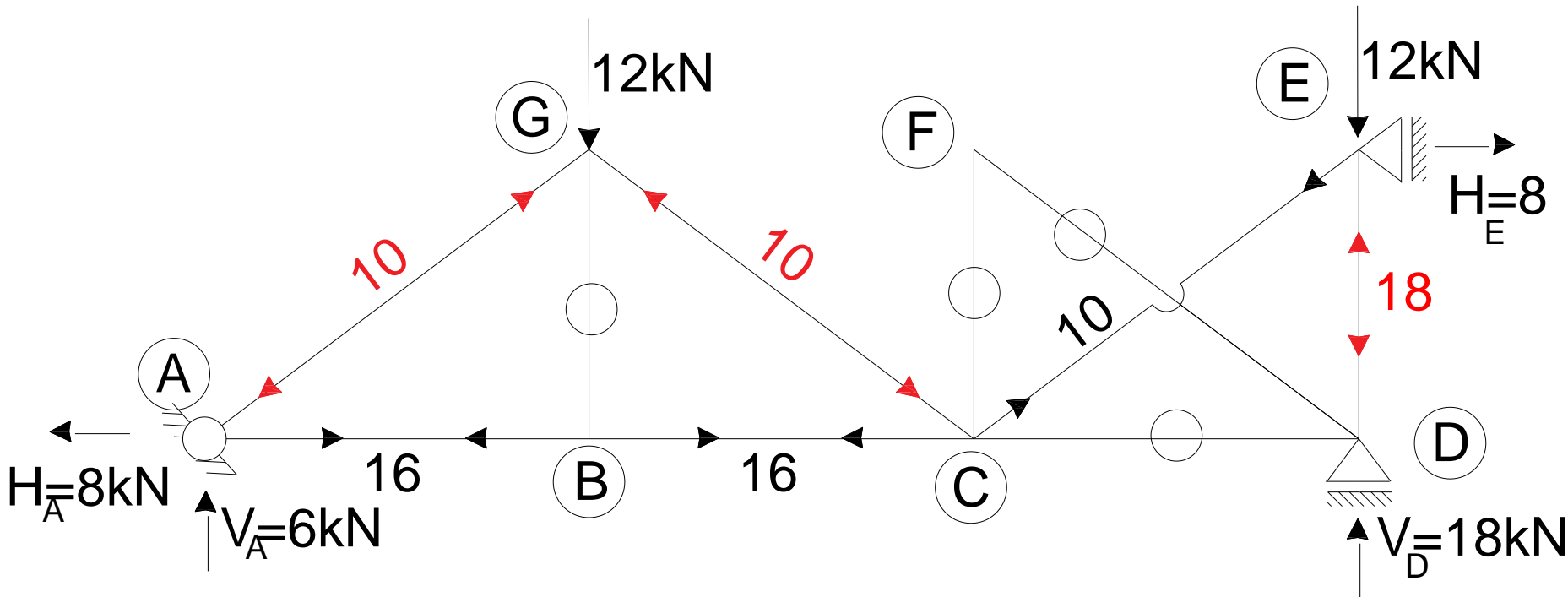

pręt	L/EA	N0
D1	4	16
D2	4	16
D3	4	0
G1	4	0
S1	3	0
S2	3	0
S3	3	-18
K1	5	0
K2	5	-10
K3	5	-10
K4	5	10
K5	5	0

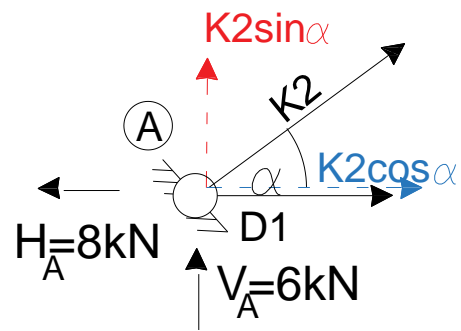
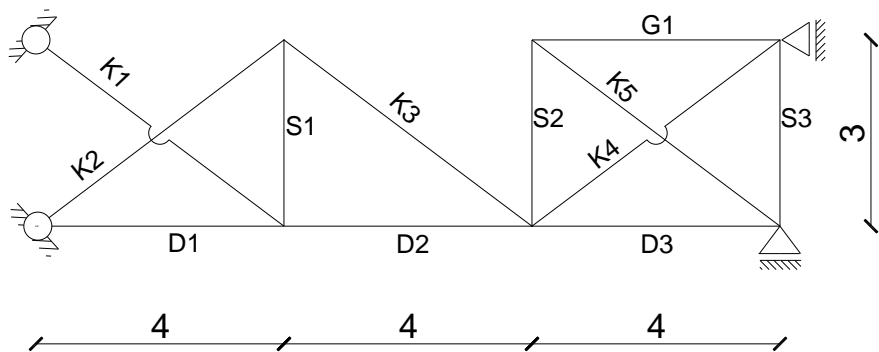

$$\sum R_Y = 6 + K2 \sin \alpha = 0$$

$$K2 = -\frac{6}{\sin \alpha} = -6 \cdot \frac{5}{3} = -10 \text{ kN}$$

$$\sum R_X = -8 + K2 \cos \alpha + D1 = 0$$

$$D1 = 8 - K2 \cos \alpha = 8 - (-10) \cdot \frac{4}{5} = 16 \text{ kN}$$

Obliczenia metody sił:

Pręt	L/EA	N1	N2	N0	$\frac{N1 \cdot N1 \cdot L}{EA}$	$\frac{N1 \cdot N2 \cdot L}{EA}$	$\frac{N2 \cdot N2 \cdot L}{EA}$	$\frac{N1 \cdot N0 \cdot L}{EA}$	$\frac{N2 \cdot N0 \cdot L}{EA}$	N1*X1	N2*X2	N	$\frac{N1 \cdot N \cdot L}{EA}$	$\frac{N2 \cdot N \cdot L}{EA}$
					EA	EA	EA	EA	EA				EA	
D1	4	-1,6	0	16	10,24	0	0	-102,4	0	-16,476	0,000	-0,476	3,046	0,000
D2	4	-0,8	0	16	2,56	0	0	-51,2	0	-8,238	0,000	7,762	-24,839	0,000
D3	4	0	1	0	0	0	4	0	0	0,000	2,366	2,366	0,000	9,462
G1	4	0	1	0	0	0	4	0	0	0,000	2,366	2,366	0,000	9,462
S1	3	-0,6	0	0	1,08	0	0	0	0	-6,178	0,000	-6,178	11,121	0,000
S2	3	0	0,75	0	0	0	1,6875	0	0	0,000	1,774	1,774	0,000	3,992
S3	3	0,3	0,75	-18	0,27	0,675	1,6875	-16,2	-40,5	3,089	1,774	-13,137	-11,823	-29,557
K1	5	1	0	0	5	0	0	0	0	10,297	0,000	10,297	51,487	0,000
K2	5	0,5	0	-10	1,25	0	0	-25	0	5,149	0,000	-4,851	-12,128	0,000
K3	5	0,5	0	-10	1,25	0	0	-25	0	5,149	0,000	-4,851	-12,128	0,000
K4	5	-0,5	-1,25	10	1,25	3,125	7,8125	-25	-62,5	-5,149	-2,957	1,894	-4,736	-11,840
K5	5	0	-1,25	0	0	0	7,8125	0	0	0,000	-2,957	-2,957	0,000	18,481
					22,9	3,8	27	-244,8	-103				0,000	0,000
					δ_{11}	δ_{12}	δ_{22}	δ_{10}	δ_{20}					

Układ równań metody sił:

$$\begin{aligned}
 \delta_{11} \cdot x1 + \delta_{12} \cdot x2 + \delta_{10} &= 0 \\
 \delta_{21} \cdot x1 + \delta_{22} \cdot x2 + \delta_{20} &= 0
 \end{aligned}
 \quad \rightarrow \quad
 \begin{aligned}
 22,9 \cdot x1 + 3,8 \cdot x2 - 244,8 &= 0 \\
 3,8 \cdot x1 + 27 \cdot x2 - 103 &= 0
 \end{aligned}
 \quad \rightarrow \quad
 \begin{aligned}
 x1 &= 10,297 \text{ kN} \\
 x2 &= 2,366 \text{ kN}
 \end{aligned}$$

Końcowy wykres sił normalnych – N [kN]

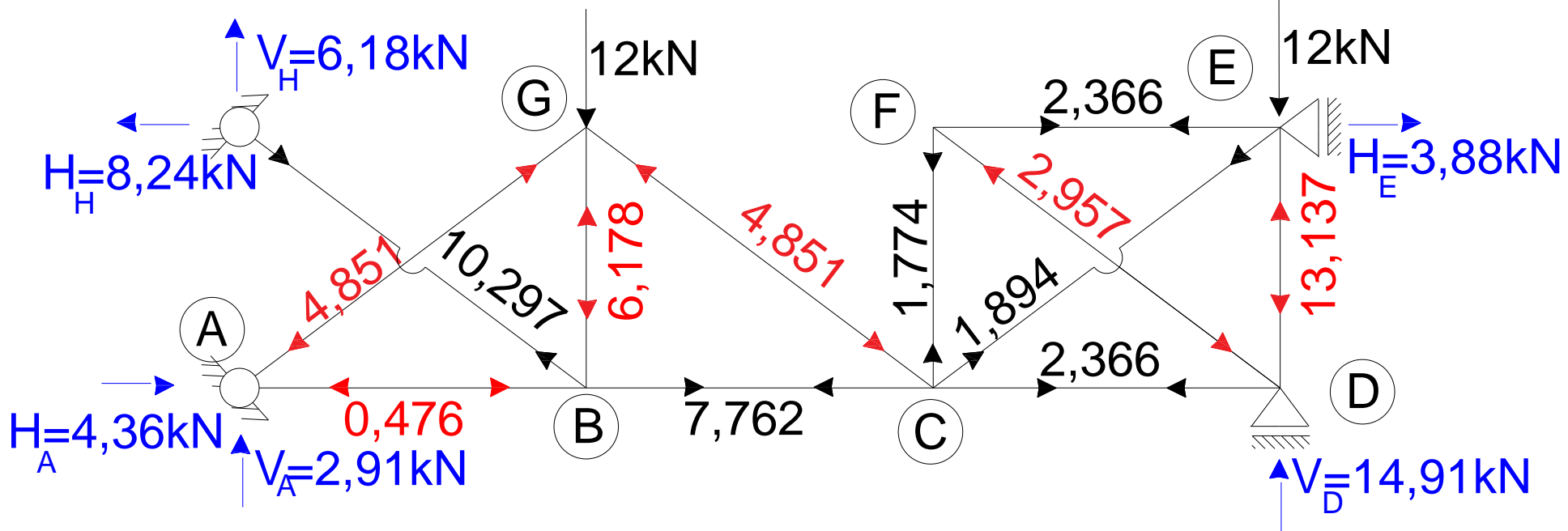

pręt	L/EA	N
D1	4	-0,476
D2	4	7,762
D3	4	2,366
G1	4	2,366
S1	3	-6,178
S2	3	1,774
S3	3	-13,137
K1	5	10,297
K2	5	-4,851
K3	5	-4,851
K4	5	1,894
K5	5	-2,957

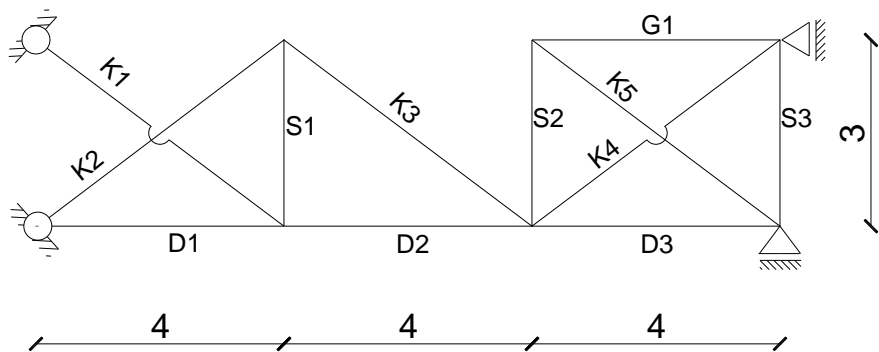

Obliczenie przemieszczenia poziomego węzła G z twierdzenia redukcyjnego:

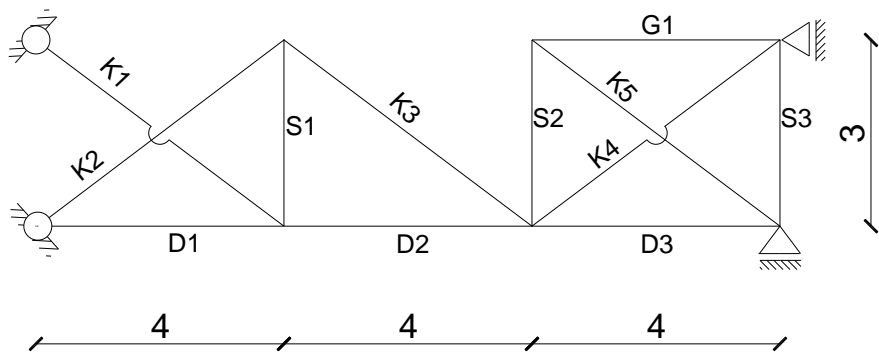
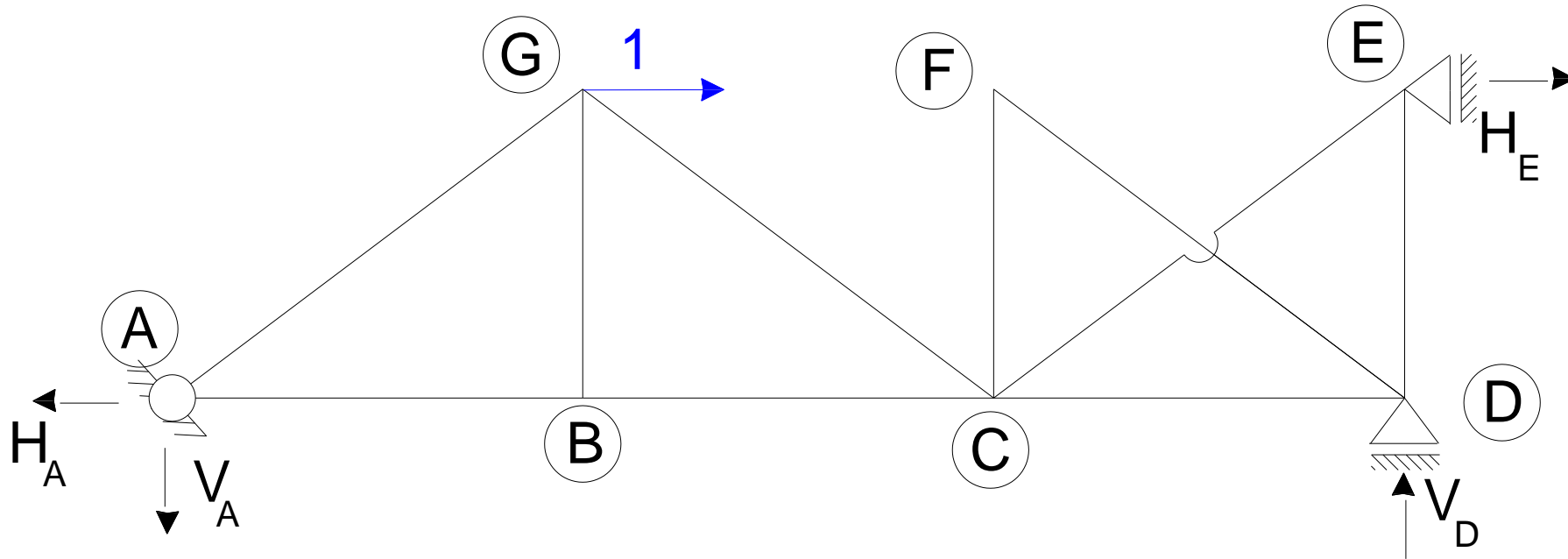

Obliczenie przemieszczenia poziomego węzła G z twierdzenia redukcyjnego:

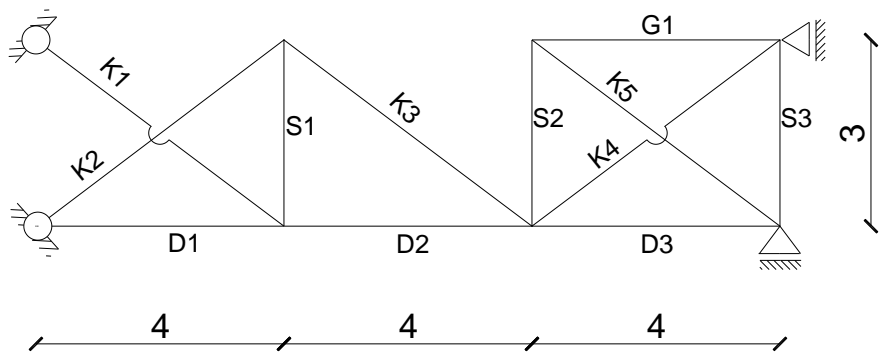
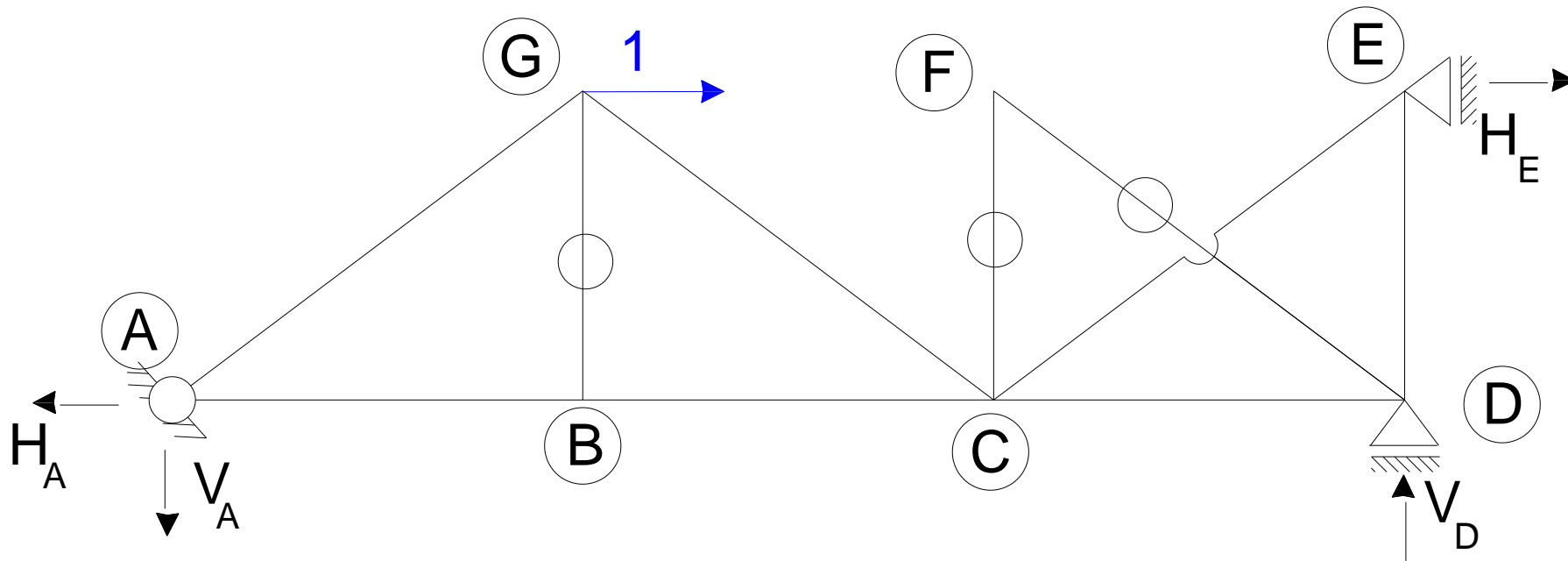

Obliczenie przemieszczenia poziomego węzła G z twierdzenia redukcyjnego:

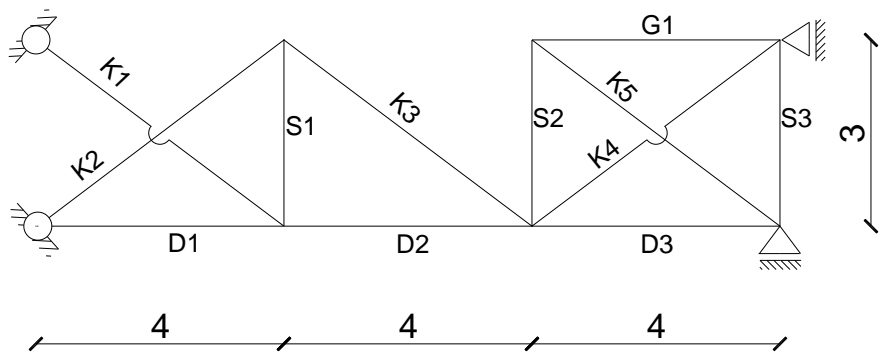
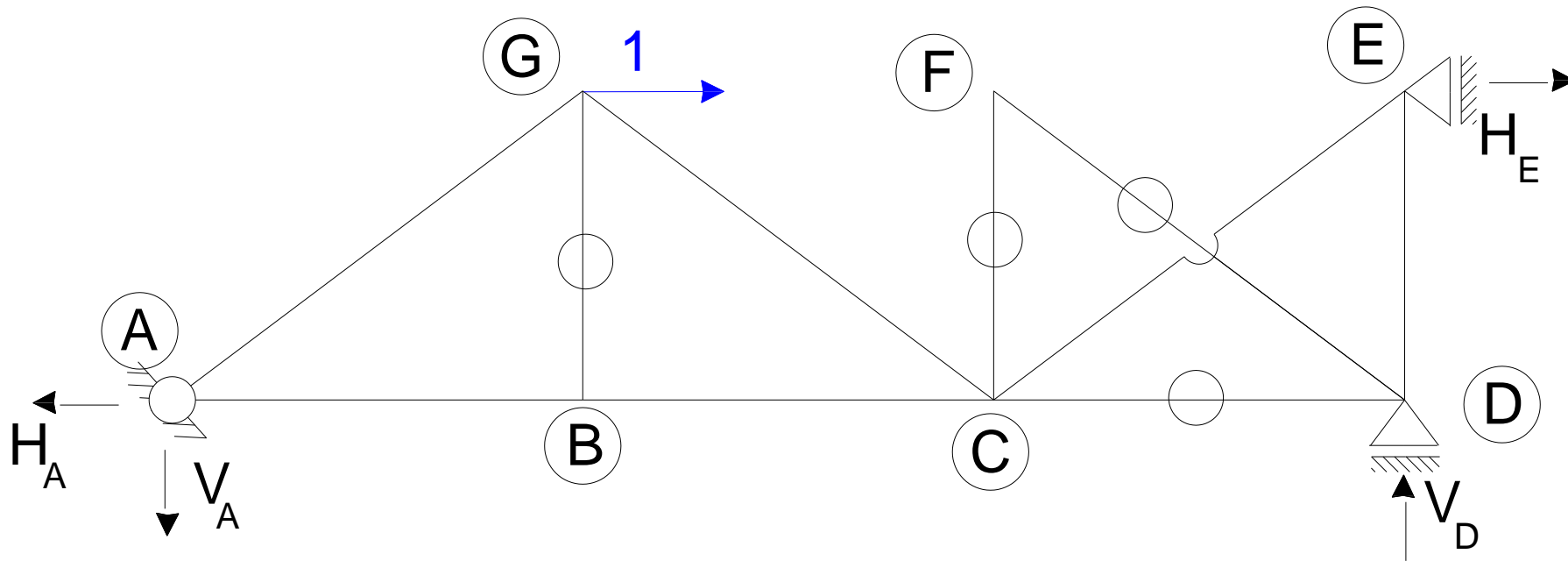

Obliczenie przemieszczenia poziomego węzła G z twierdzenia redukcyjnego:

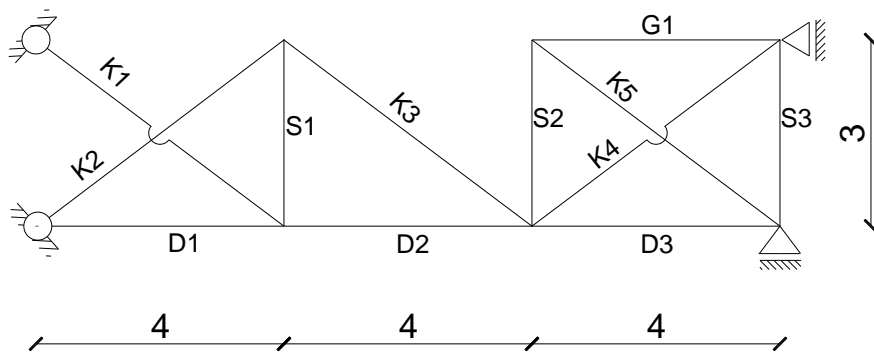
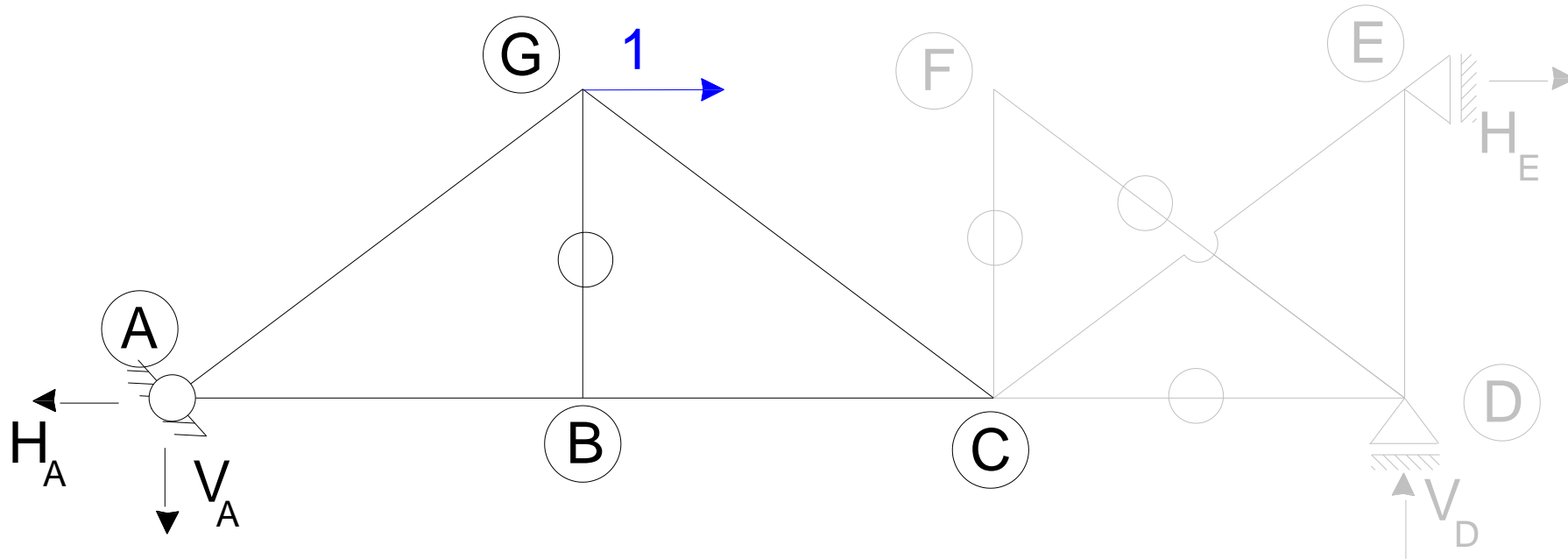

$$\sum M_C^L = 1 \cdot 3 - V_A \cdot 8 = 0 \rightarrow V_A = \frac{3}{8} = 0,375$$

Obliczenie przemieszczenia poziomego węzła G z twierdzenia redukcyjnego:

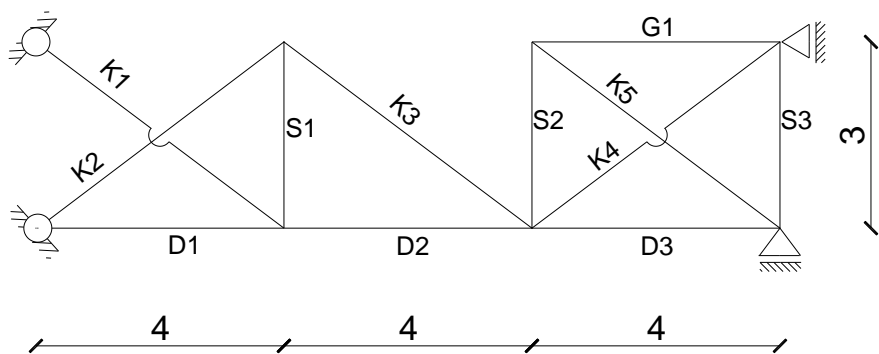
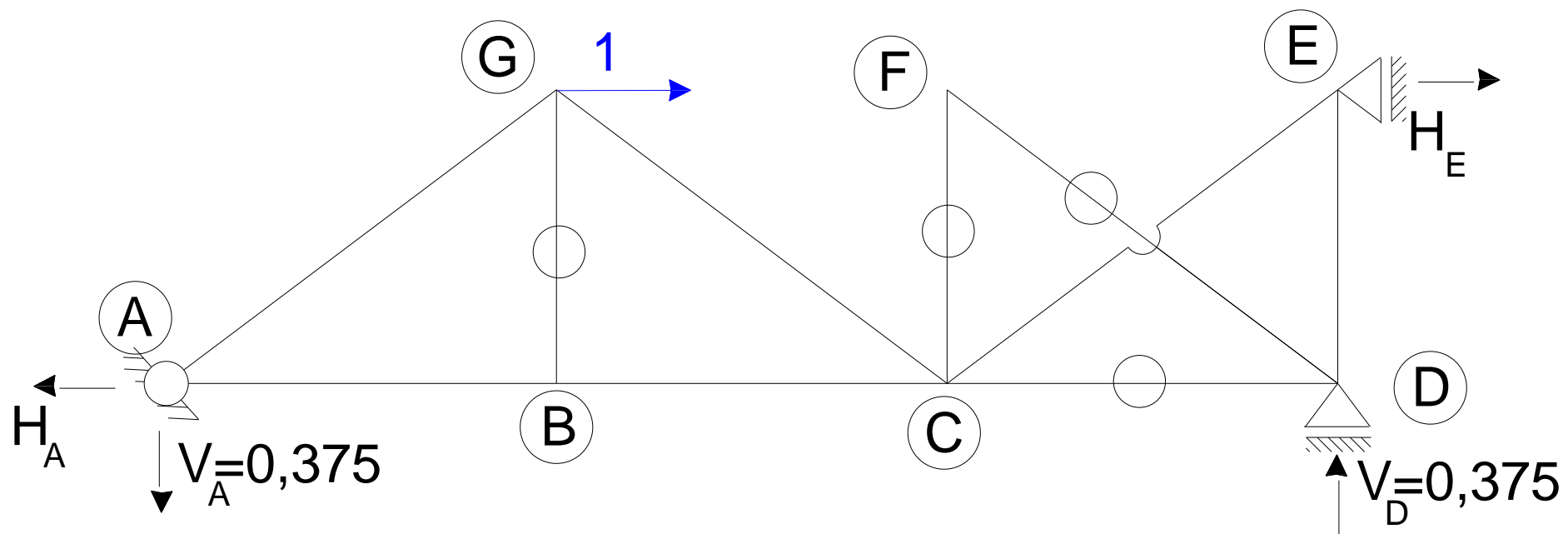

$$\sum M_C^L = 1 \cdot 3 - V_A \cdot 8 = 0 \rightarrow V_A = \frac{3}{8} = 0,375$$

Obliczenie przemieszczenia poziomego węzła G z twierdzenia redukcyjnego:

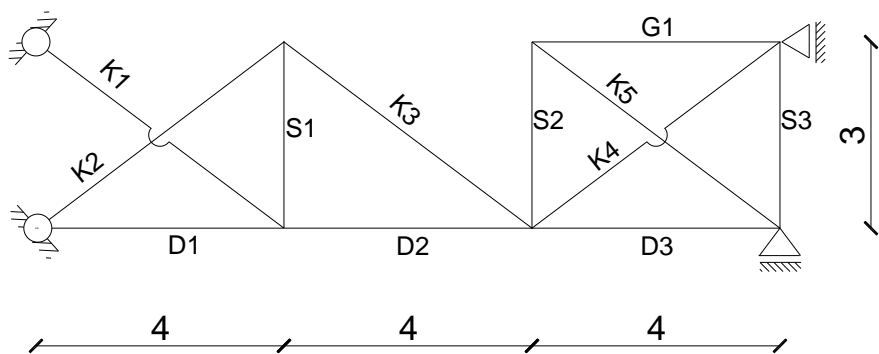
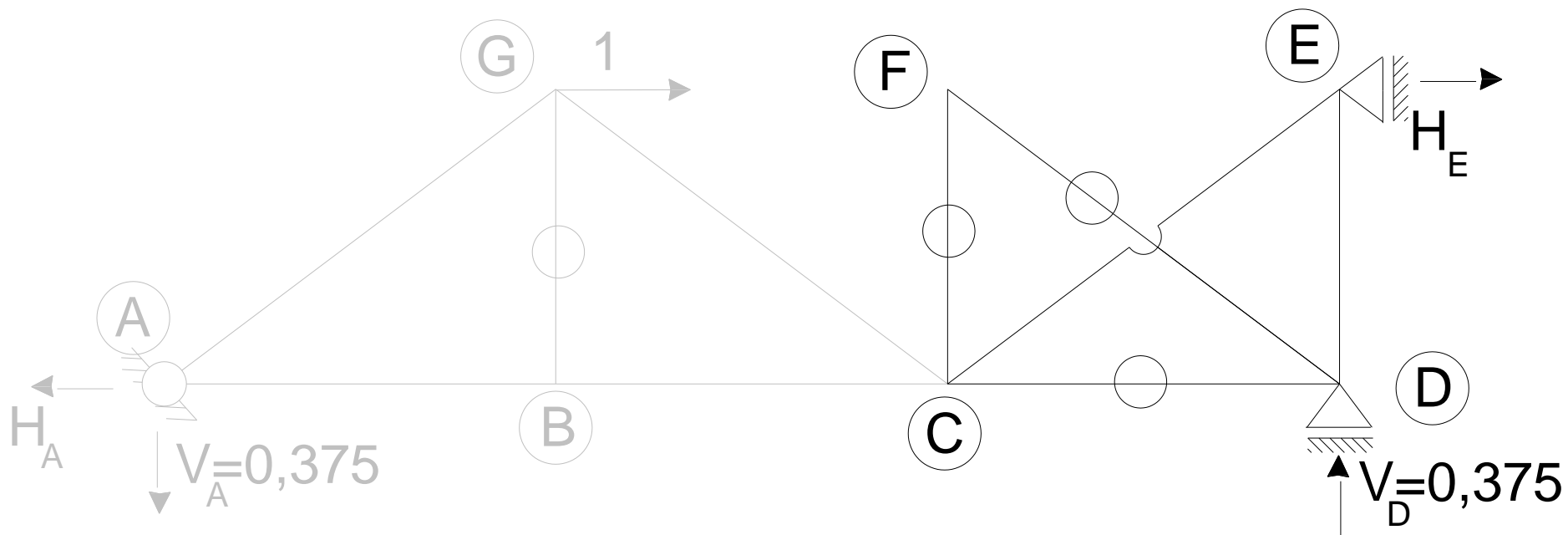

$$\sum M_C^L = 1 \cdot 3 - V_A \cdot 8 = 0 \rightarrow V_A = \frac{3}{8} = 0,375$$

$$\sum M_C^P = H_E \cdot 3 - 0,375 \cdot 4 = 0 \rightarrow H_E = \frac{0,375 \cdot 4}{3} = 0,5$$

Obliczenie przemieszczenia poziomego węzła G z twierdzenia redukcyjnego:

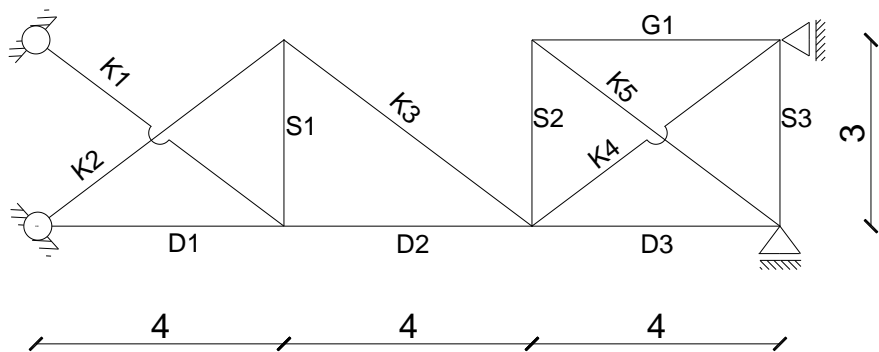
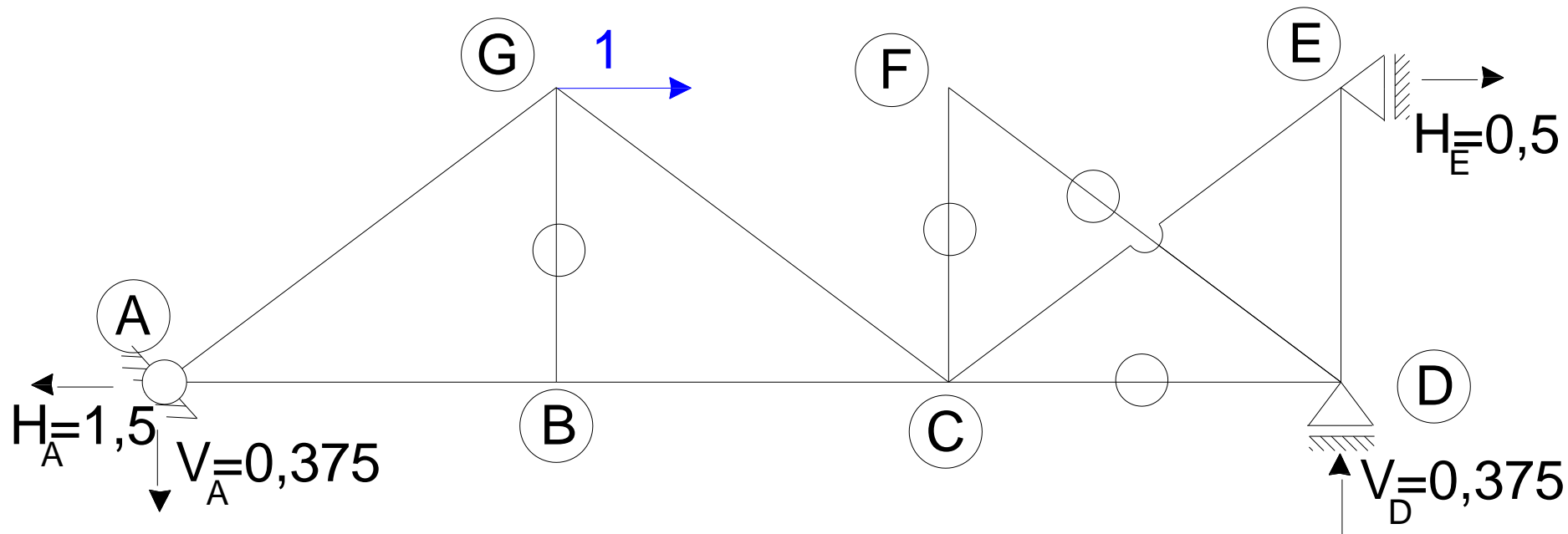

$$\sum M_C^L = 1 \cdot 3 - V_A \cdot 8 = 0 \rightarrow V_A = \frac{3}{8} = 0,375$$

$$\sum M_C^P = H_E \cdot 3 - 0,375 \cdot 4 = 0 \rightarrow H_E = \frac{0,375 \cdot 4}{3} = 0,5$$

Obliczenie przemieszczenia poziomego węzła G z twierdzenia redukcyjnego:

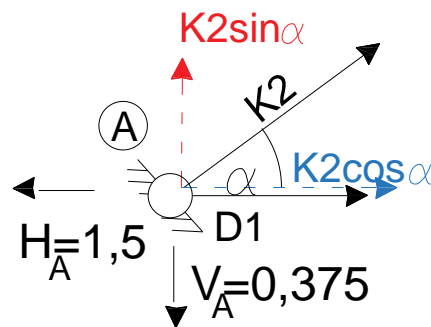
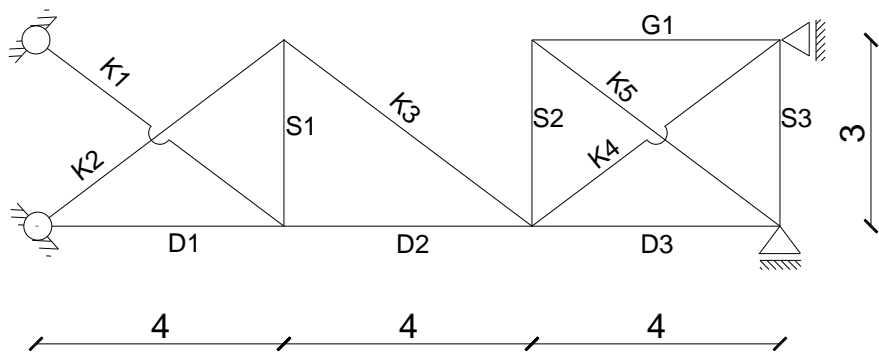
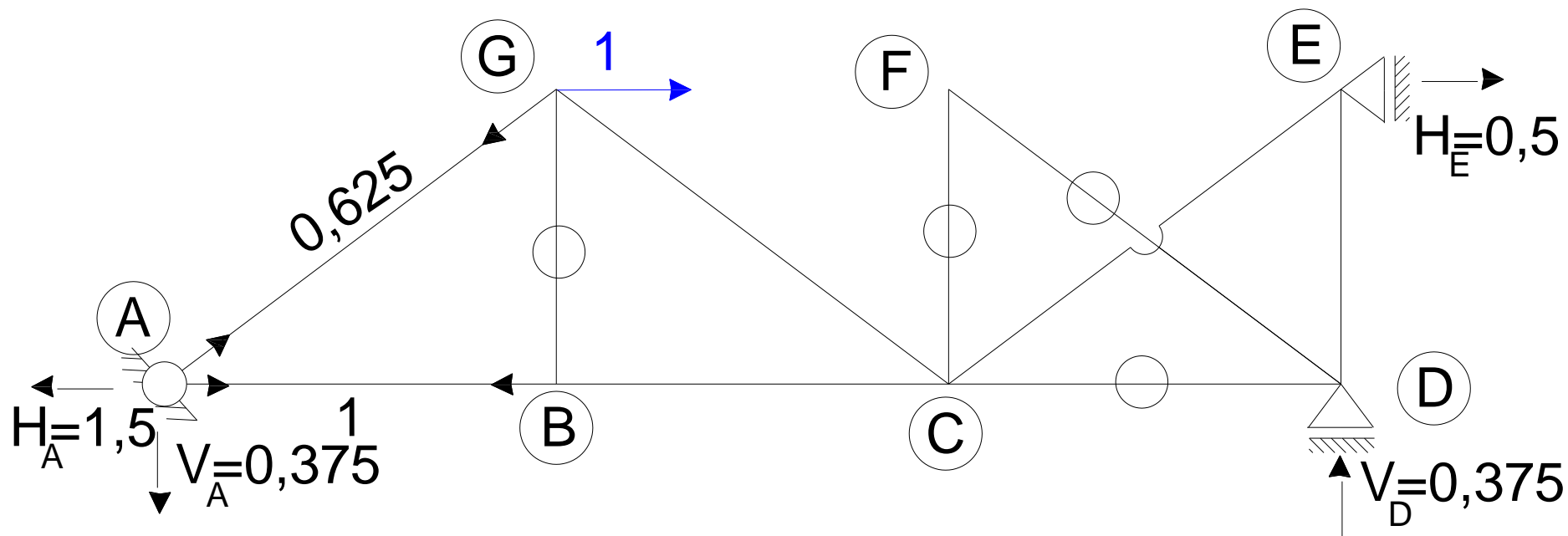

$$\sum R_Y = -0,375 + K2 \sin \alpha = 0$$

$$K2 = \frac{0,375}{\sin \alpha} = 0,375 \cdot \frac{5}{3} = 0,625$$

$$\sum R_X = -1,5 + K2 \cos \alpha + D1 = 0$$

$$D1 = 1,5 - K2 \cos \alpha = 1,5 - (0,625) \cdot \frac{4}{5} = 1$$

Obliczenie przemieszczenia poziomego węzła G z twierdzenia redukcyjnego:

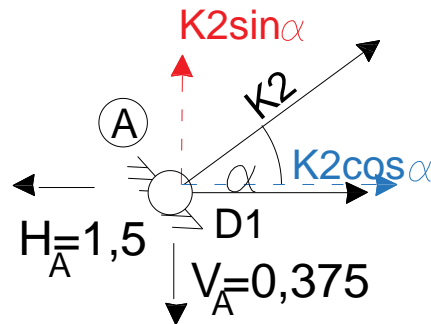
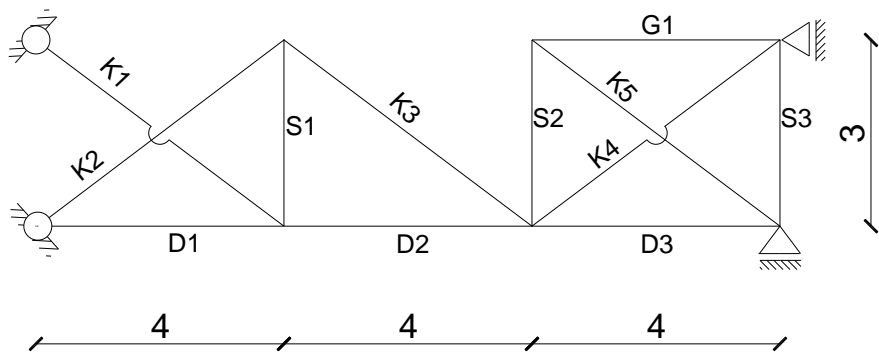
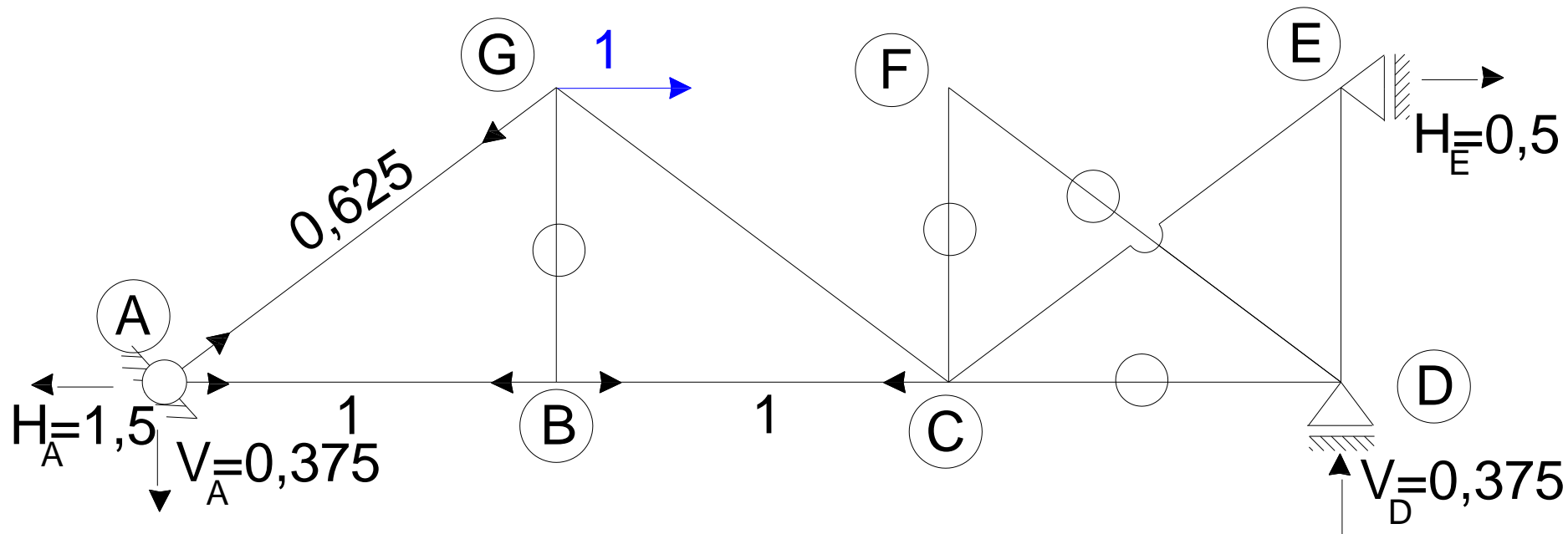

$$\sum R_Y = -0,375 + K2 \sin \alpha = 0$$

$$K2 = \frac{0,375}{\sin \alpha} = 0,375 \cdot \frac{5}{3} = 0,625$$

$$\sum R_X = -1,5 + K2 \cos \alpha + D1 = 0$$

$$D1 = 1,5 - K2 \cos \alpha = 1,5 - (0,625) \cdot \frac{4}{5} = 1$$

Obliczenie przemieszczenia poziomego węzła G z twierdzenia redukcyjnego:

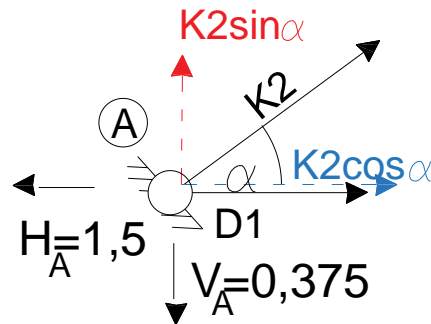
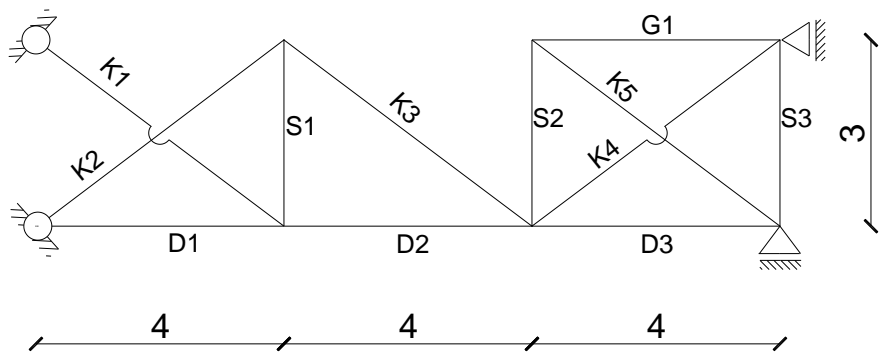
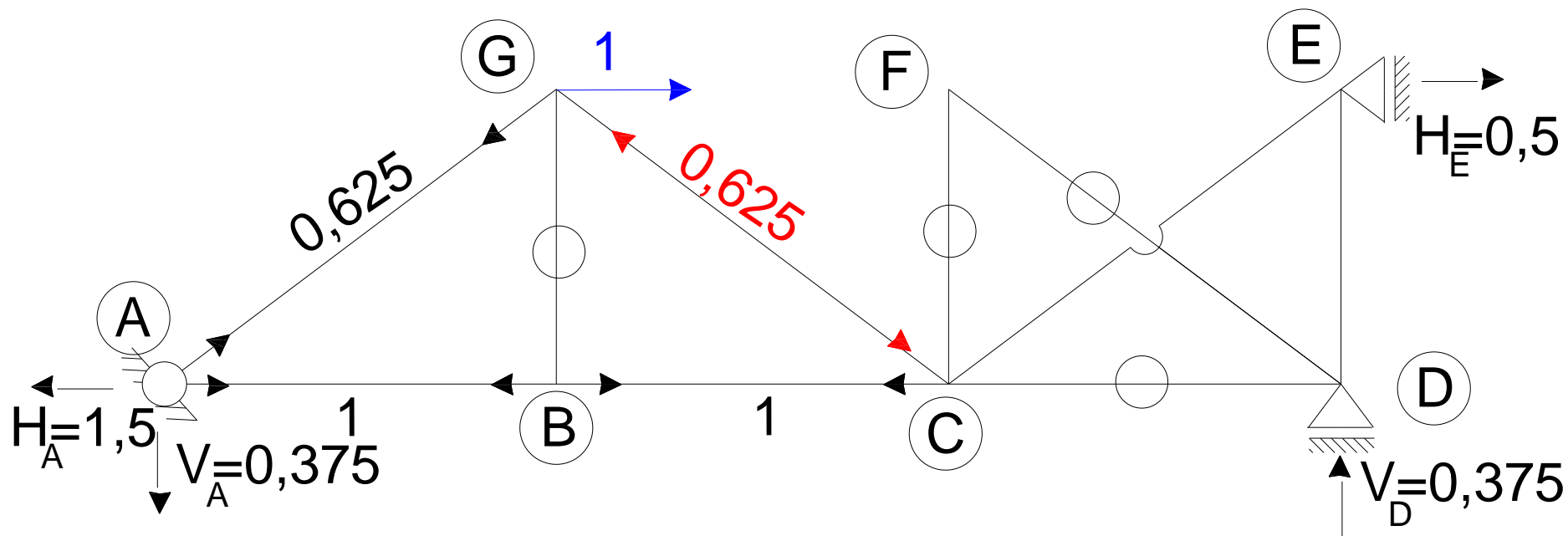

$$\sum R_Y = -0,375 + K2 \sin \alpha = 0$$

$$K2 = \frac{0,375}{\sin \alpha} = 0,375 \cdot \frac{5}{3} = 0,625$$

$$\sum R_X = -1,5 + K2 \cos \alpha + D1 = 0$$

$$D1 = 1,5 - K2 \cos \alpha = 1,5 - (0,625) \cdot \frac{4}{5} = 1$$

Obliczenie przemieszczenia poziomego węzła G z twierdzenia redukcyjnego:

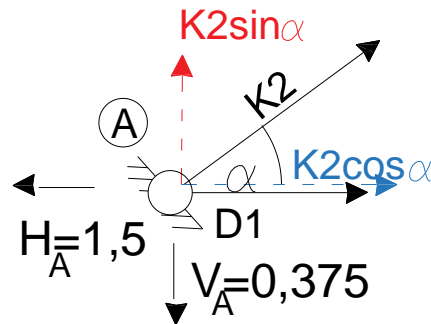
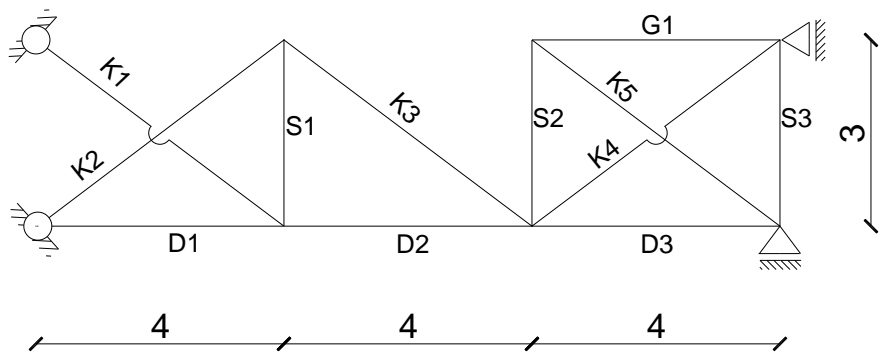
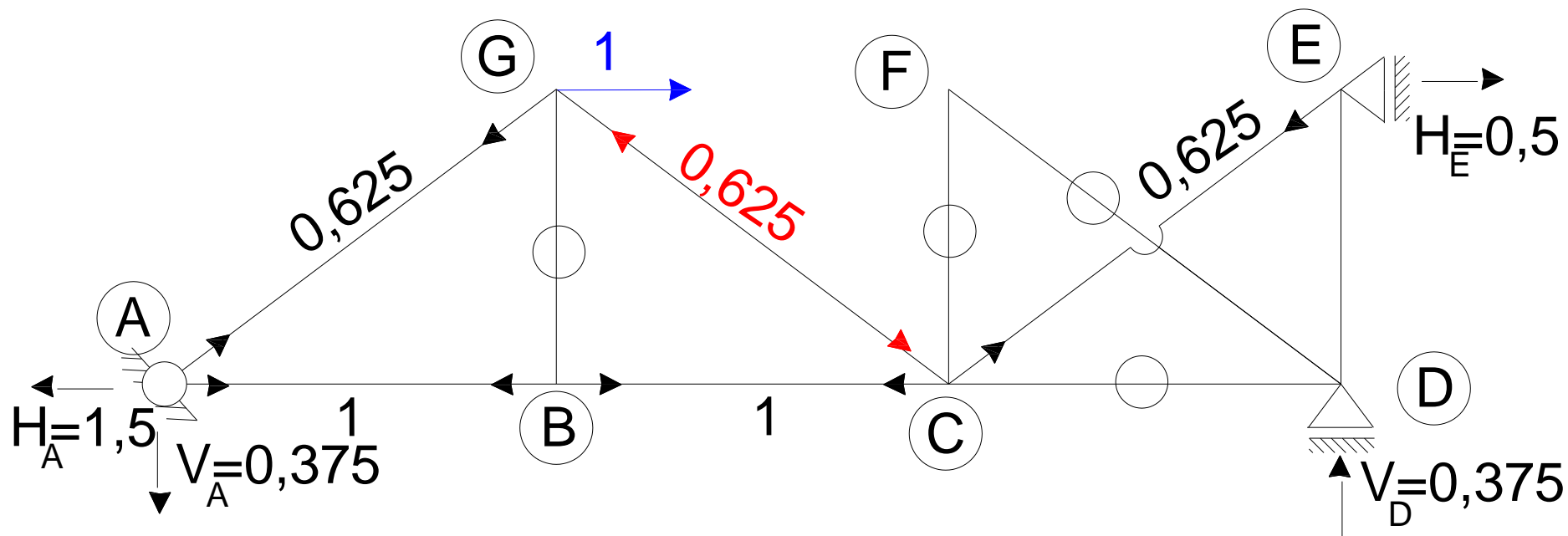

$$\sum R_Y = -0,375 + K2 \sin \alpha = 0$$

$$K2 = \frac{0,375}{\sin \alpha} = 0,375 \cdot \frac{5}{3} = 0,625$$

$$\sum R_X = -1,5 + K2 \cos \alpha + D1 = 0$$

$$D1 = 1,5 - K2 \cos \alpha = 1,5 - (0,625) \cdot \frac{4}{5} = 1$$

Obliczenie przemieszczenia poziomego węzła G z twierdzenia redukcyjnego:

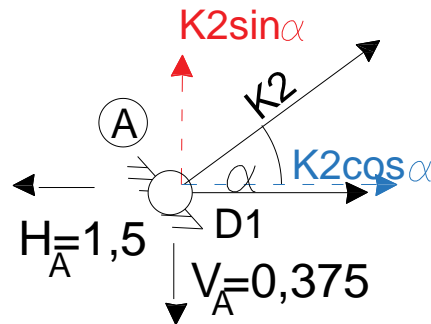
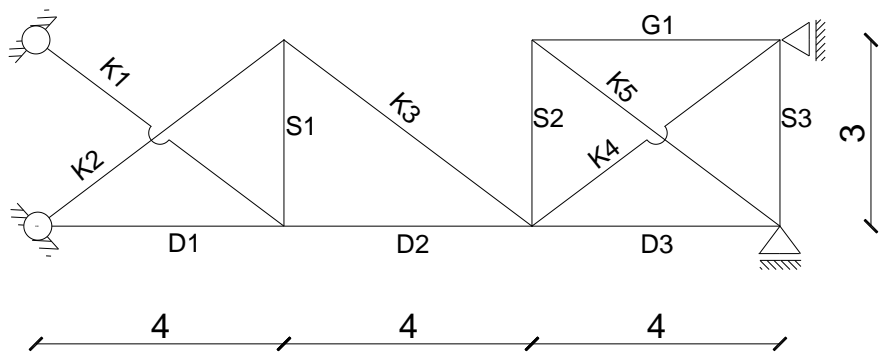
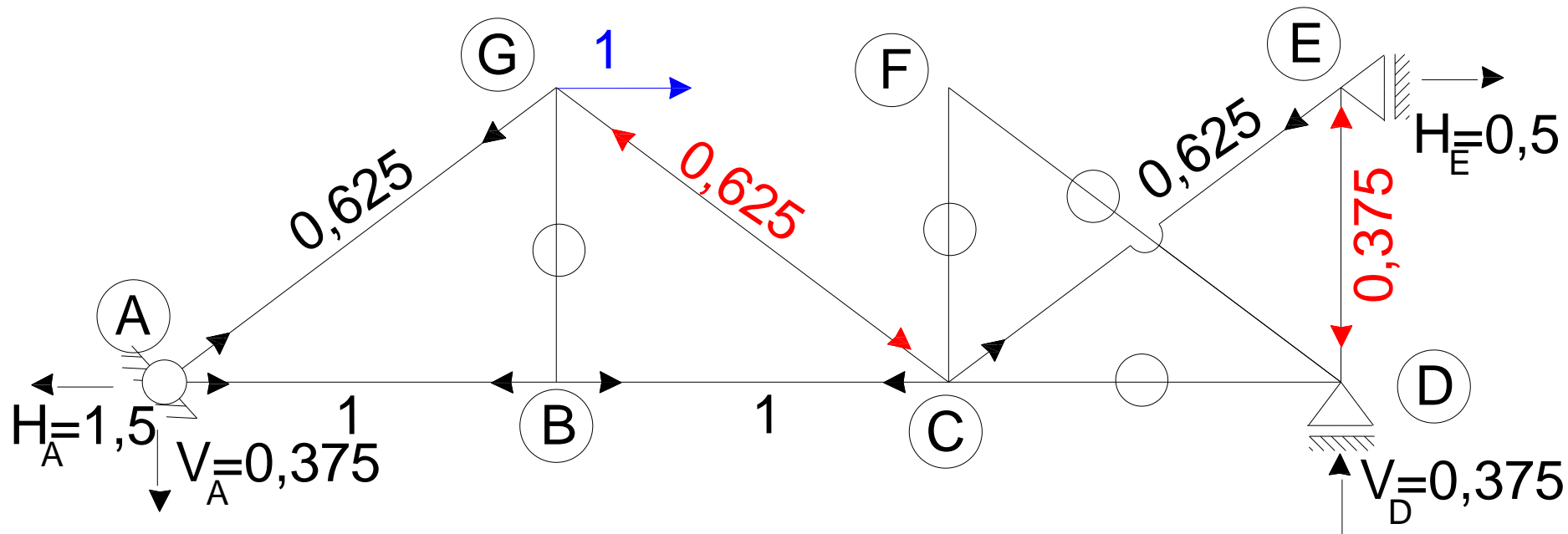

$$\sum R_Y = -0,375 + K2 \sin \alpha = 0$$

$$K2 = \frac{0,375}{\sin \alpha} = 0,375 \cdot \frac{5}{3} = 0,625$$

$$\sum R_X = -1,5 + K2 \cos \alpha + D1 = 0$$

$$D1 = 1,5 - K2 \cos \alpha = 1,5 - (0,625) \cdot \frac{4}{5} = 1$$

Obliczenie przemieszczenia poziomego węzła G z twierdzenia redukcyjnego:

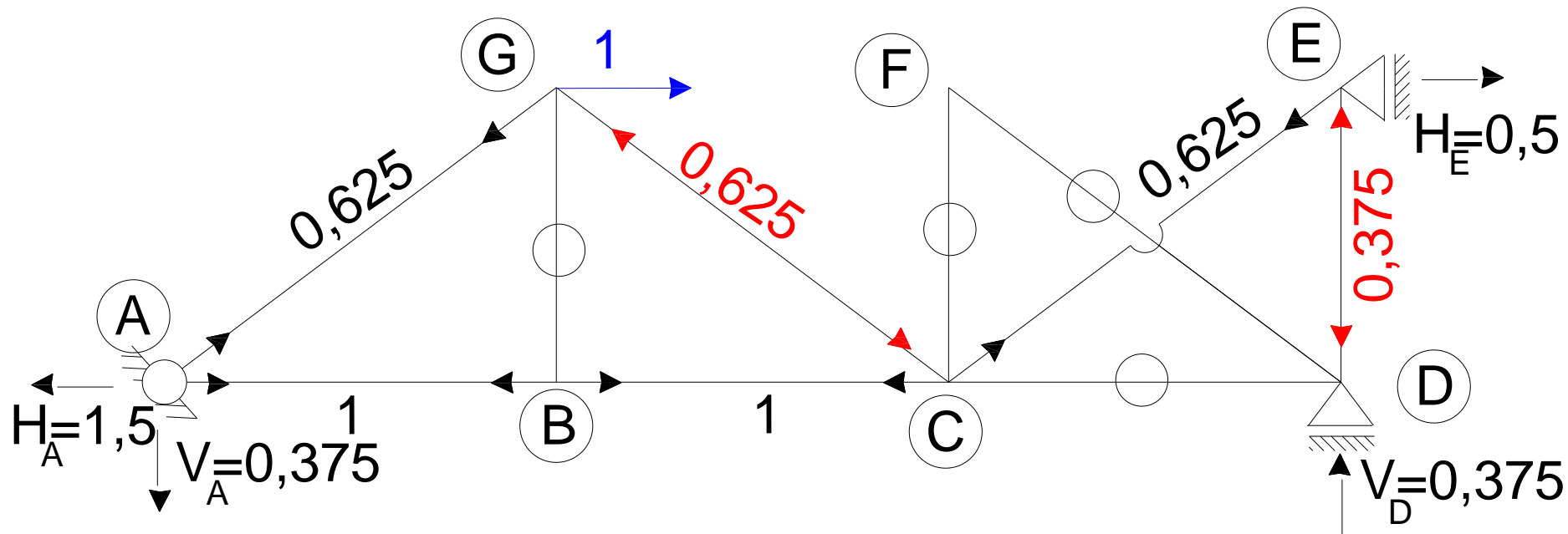

pręt	L/EA	\bar{N}
D1	4	1
D2	4	1
D3	4	0
G1	4	0
S1	3	0
S2	3	0
S3	3	-0,375
K1	5	0
K2	5	0,625
K3	5	-0,625
K4	5	0,625
K5	5	0

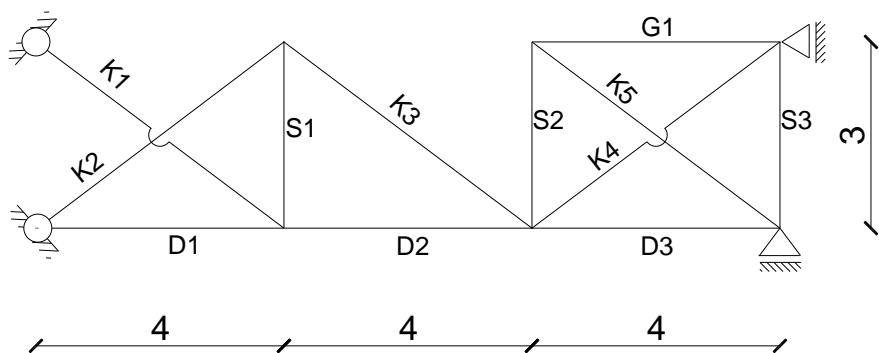

Obliczenie przemieszczenia poziomego węzła G z twierdzenia redukcyjnego:

Pręt	L/EA	\bar{N}	N	$\bar{N} * N * L / EA$
D1	4	1	-0,476	-1,903
D2	4	1	7,762	31,048
D3	4	0	2,366	0,000
G1	4	0	2,366	0,000
S1	3	0	-6,178	0,000
S2	3	0	1,774	0,000
S3	3	-0,375	-13,137	14,779
K1	5	0	10,297	0,000
K2	5	0,625	-4,851	-15,160
K3	5	-0,625	-4,851	15,160
K4	5	0,625	1,894	5,920
K5	5	0	-2,957	0,000
				49,843

Przemieszczenie poziome węzła G wynosi $u_G = 49,843/EA$